



e-ISSN: 2278-8875

p-ISSN: 2320-3765

International Journal of Advanced Research

in Electrical, Electronics and Instrumentation Engineering

Volume 13, Issue 4, April 2024

ISSN INTERNATIONAL
STANDARD
SERIAL
NUMBER
INDIA

Impact Factor: 8.317

☎ 9940 572 462

☎ 6381 907 438

✉ ijareeie@gmail.com

@ www.ijareeie.com



Biometric and Voice Command Motorcycle Security System with Alcohol Detection

Irfan Mohammed¹, Praison G Raju², Shravana R³, Yedhu Krishann O⁴, Shahana Habeeb Mohammad⁵,
Shejin Mathulla Thomas⁶

UG Student, Dept. of ECE, Mount Zion College of Engineering Kadammanitta, Pathanamthitta, India¹

UG Student, Dept. of ECE, Mount Zion College of Engineering Kadammanitta, Pathanamthitta, India²

UG Student, Dept. of ECE, Mount Zion College of Engineering Kadammanitta, Pathanamthitta, India³

UG Student, Dept. of ECE, Mount Zion College of Engineering Kadammanitta, Pathanamthitta, India⁴

Asst. Professor, Dept. of ECE, Mount Zion College of Engineering Kadammanitta, Pathanamthitta, India⁵

Asst. Professor, Dept. of ECE, Mount Zion College of Engineering Kadammanitta, Pathanamthitta, India⁶

ABSTRACT: Enhancing the security measures in motorcycles is imperative given the prevalence of theft incidents facilitated by the current weak mechanical locks. Consequently, there's a pressing need for an advanced security system to support the protection of motorcycles. This endeavour outlines the development of such a system, integrating fingerprint recognition and voice command capabilities for access. The outcomes of this initiative demonstrate a marked enhancement in security compared to conventional mechanical key systems. With the alarming rise in road accidents, prioritizing rider safety is paramount. This project aims to mitigate accident risks by addressing common causes such as alcohol impairment and drowsiness. Upon detecting these factors, the system alerts the rider via an alarm and, if stationary, automatically disables the ignition and locks the bike as a precautionary measure.

KEYWORDS: Motorcycle Security System, Biometric- Voice Command Based Solution, Alcohol Detection, Smart Helmet.

I. INTRODUCTION

In the modern world, the use of vehicles is increasing day by day. Especially motorcycles. Motorcycles are more suitable for single-person use. Incidents of theft are also on the rise due to weak security systems and accidents due to drunken driving. Traditional motorcycle security systems typically rely on physical locks and keys, which can be prone to vulnerabilities such as theft or unauthorized access. Physical locks and keys can be easily bypassed or manipulated by experienced thieves, rendering the security measures ineffective. Additionally, traditional systems offer limited functionality and convenience, often requiring riders to carry bulky keys or remember complex lock combinations. Furthermore, these systems do not provide real-time monitoring or alerts in the event of unauthorized access or tampering, leaving motorcycles vulnerable to theft without immediate detection. Traditional motorcycle security systems are limited in their effectiveness and fail to address the crucial issue of rider safety about alcohol consumption.

II. PROPOSED SYSTEM

Introducing the next level of motorcycle security: a cutting-edge system integrating fingerprint and voice command recognition all supported by an alcohol-detecting feature and driven by a microcontroller. The days of traditional locks and keys are long gone. This cutting-edge biometric security system uses innovative technology to transform motorcycle protection. With fingerprint recognition, only authorized users can access the motorcycle, ensuring unparalleled security and peace of mind. However, it doesn't end there. An additional degree of security and convenience is provided via voice command capability. Imagine being able just to use your voice to start or stop your motorcycle, making the whole process simple and natural. Furthermore, safety is of utmost importance. The system includes an alcohol detection feature, ensuring that only sober riders can operate the motorcycle. This not only reduces the risk of accidents but also encourages responsible riding behaviour. All these cutting-edge features seamlessly integrate into a compact microcontroller, making installation and operation hassle-free. With this groundbreaking security system, riders can confidently safeguard their motorcycles while enjoying the benefits of modern technology.



III. BLOCK DIAGRAM

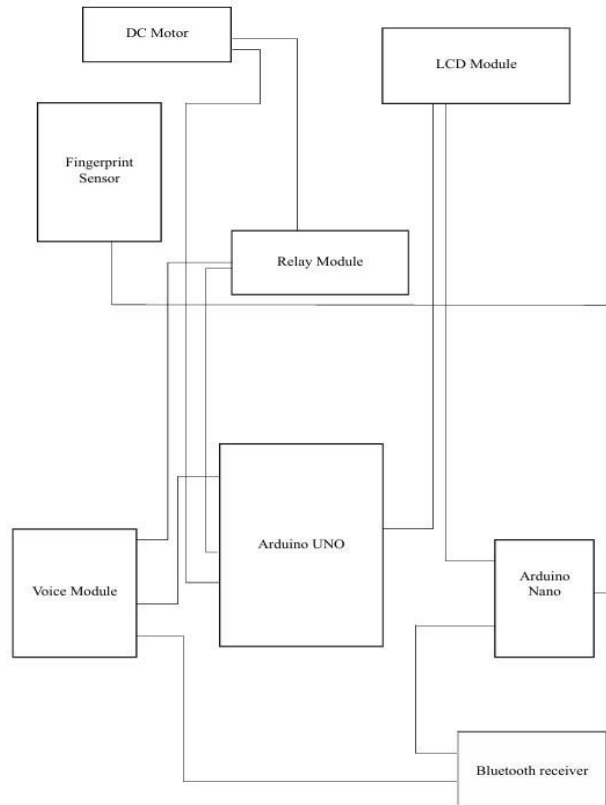

Fig (1) Block diagram of motorcycle security system

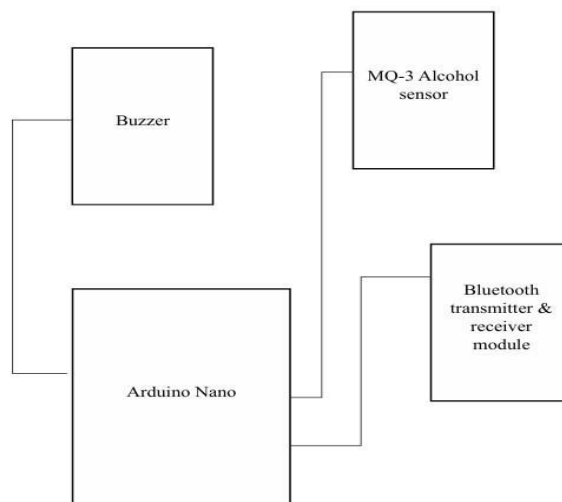

Fig (2) Block diagram of smart helmet

Figure 1 comprises an Arduino UNO microcontroller, a fingerprint sensor, a voice module, Bluetooth receiver and transmitter modules, a relay module, an LCD, and a DC Motor. The Arduino is powered by 5 volts, supplying power to all connected components. Upon activation, the LCD module prompts the user with the instruction "Place your finger to



scan." Once a fingerprint is scanned, the sensor sends a signal to the microcontroller. If the fingerprint matches, a command ("Speak Now") is displayed on the LCD. If there is no match, the ignition remains inactive. The voice module receives and processes voice commands, contributing to safety. A positive match triggers the ignition. The motor indicates the 5V output from the microcontroller. Figure 2 features an Arduino UNO, an MQ3 sensor, a buzzer, and a 5V power supply. The MQ3 sensor detects alcohol in the breath, sending a signal to the microcontroller, activating the buzzer, and preventing ignition. The buzzer alerts the user against riding. This intelligent system, installed within the helmet, requires a 5V supply from the battery for operation.

IV. CIRCUIT DIAGRAM

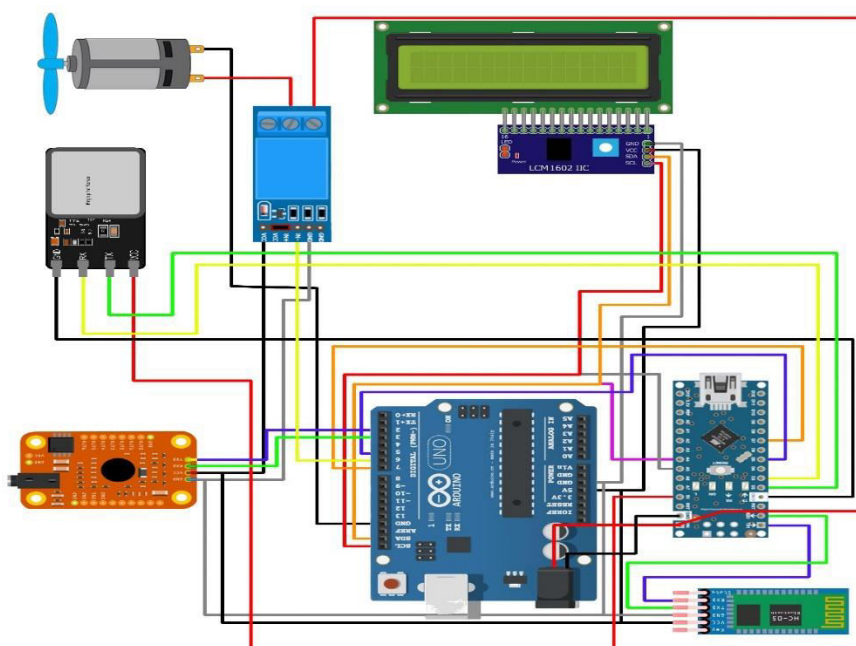

Fig (3) Circuit diagram of motorcycle security system

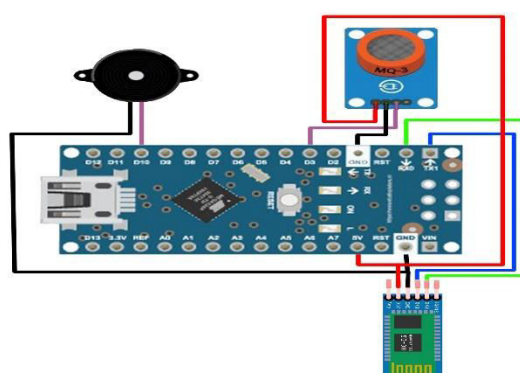

Fig (4) Circuit diagram of smart helmet

The “Biometric and voice command motorcycle security system with alcohol detection” uses two 18650 lithium-ion batteries connected in series to provide the Arduino UNO and Arduino Nano microcontrollers with 8V DC. The power supply is turned on and off using a switch. The fingerprint sensor's two data pins are connected to the D2 and D3 pins on the Arduino Nano, and its ground is connected to the GND pin of the device. The 5V output of the Arduino Nano provides 5V to the fingerprint sensor. The TXD and RXD pins of the Bluetooth module HC-05 are connected to the Arduino Nano's TX1 and RX0 pins, respectively. Digital Pins 7 and 5 of the Arduino UNO are connected to the D5 and D7 pins of the Arduino Nano, respectively. The ground pin is linked to the Arduino UNO's GND, and the 5V output of the UNO



supplies the Bluetooth module with 5V input. The A4 and A5 pins of the Arduino Nano are connected to the SDA and SCL pins of the Arduino UNO, respectively. The VOICE module's TXD and RXD are connected to digital pins 2 and 3 on the Arduino UNO, respectively. The Arduino UNO's GND is connected to its GND, and the voice module receives the 5V output from the UNO connected to its VCC. The LCD's VCC is connected to the Arduino UNO's 5V output, and the GND pin is connected to the Arduino UNO's GND. The SDA and SCL pins of the LCD are linked to the corresponding SDA and SCL pins of the Arduino UNO. A DC motor is connected to the common pin of the relay, and the other end is connected to the GND of the Arduino UNO. The NO pin of the relay receives 8V DC from the power supply. The input signal for the relay comes from digital pin 6 on the Arduino UNO, and 5V and GND are supplied to the Relay from the 5V output and GND of the Arduino UNO. The module in the helmet contains Arduino nano, Bluetooth module HC-05, buzzer, and MQ3 sensor. The digital pins from the Bluetooth module are connected to the TX1 and RX0 pins on the Arduino nano. The input of the buzzer is connected to the D10 pin on the Arduino nano and the GND is connected to the GND of the Arduino nano. The data pin on the MQ3 sensor is connected to the D3 pin on the Arduino nano, both the Bluetooth module and the MQ3 sensor are supplied with 5V and GND from the Arduino nano.

V. WORKING

In the Arduino family, one of the most popular microcontroller boards is the Uno. At its core is an ATmega328P microprocessor, which operates at 16 MHz. The Uno board has six analog inputs, six digital input/output pins (six of which can be used as PWM outputs), a power jack, an ICSP header, a reset button, a USB port for programming, and other features. Because of its ease of use and versatility, it is frequently used for interactive electronic project creation and prototyping. A smaller, more breadboard-friendly variant of the Arduino board is called the Arduino Nano. It is built around the ATmega328 microprocessor, which has a smaller form size than the Uno. The majority of the Uno's features are still included in the Nano despite its smaller size, including eight analog inputs, six PWM output pins among the 14 digital input/output pins, a USB interface for programming and power, an ICSP header, and a reset button. The Nano is especially well suited for situations where portability is important or where there are space limits. Due to its compact size, it is perfect for wearable electronics integration or embedding into completed products. Two lithium-ion batteries (18650) connected in series provide the Arduino Uno with 7.4V of power. The power supply is turned on and off via a switch. The Arduino Uno stores the data that will be displayed on the LCD. The Arduino Uno receives 5 volts of direct current from the Arduino Board. Additionally, the Arduino Uno receives connections from the SD Card and SD Analyzer. The Arduino Uno is also connected to the Voice Module through digital pins 2 and 3 on the Arduino Board. The Arduino Uno's VCC and GND are connected to the 5 volts from the Arduino Uno. The Arduino Uno's input is connected to the 6th pin on the Arduino Uno, and the Arduino Uno provides the relay with 5 volts of power. The Arduino Uno's ground is connected to the DC motor's ground, and the motor's middle section is connected to the relay's other side, which receives 7.4 volts from the battery. The tx and rx from the fingerprint sensor are connected to the d2 and d3 of the Arduino Nano, and 5v is supplied. The Arduino Nano is used to store data from the fingerprint sensor and the Bluetooth HC 06 receiver module from the Arduino Nano to the VCC of the fingerprint sensor. The Arduino Nano's txd and rxd are linked to the rxd and txd from the Bluetooth module, and the module receives 5 volts from Nano's 5-volt output.

VI. IMPLEMENTATION

1) Hardware Implementation

Clearly outline the requirements of your motorcycle security system. Determine what parameters you want to monitor (such as security features, user interface accessibility, etc.), where the sensors will be placed, and what actions the system should take based on the data.

2) Sensor Selectors

Choose appropriate sensors for enhancing your motorcycle security system based on your requirements. Consider factors such as security, accuracy, reliability, power consumption, and compatibility with the **microcontroller**.

3) Hardware Setup

Install sensors at the desired locations to improve the motorcycle security system. Connect the sensors to microcontrollers or single-board computers (e.g., Arduino) equipped with Wi-Fi or cellular connectivity for data transmission.

4) Data Transmission

Utilize serial communication protocols (e.g., UART) for data transmission between the microcontroller and other components (e.g., sensors, display unit). Encrypt sensitive data (e.g., fingerprint data, voice data) during transmission to prevent unauthorized interception or tampering.

5) Data Storage and Processing



Set up the Arduino microcontroller's data storage and processing pipelines to handle the incoming sensor data. This may include using databases (e.g., built-in EEPROM, memory arrays, SD cards) for data storage and analytics services for real-time processing.

6) Visualization

Indicate in a section dedicated to fingerprint authentication when the system is prepared to accept fingerprint inputs. During the authentication procedure, show the user feedback messages like "Place finger on scanner" or "Authentication successful." Also, include a voice command recognition portion that indicates when the system is ready to receive orders. Show accepted commands, the actions that accompany them, and feedback messages such as "Command executed" or "Invalid command."

7) Alert and Notification

Monitor alcohol levels using the alcohol detection system and alert the user if the detected alcohol level exceeds a predefined threshold. Display a warning message on the dashboard interface and activate visual and audible alarms to alert the user of the potential risk.

VII. CONCLUSION

Additional motorcycle security system design implemented to reduce the incidence of motorcycle loss due to theft. The security system created combines a fingerprint sensor and voice commands using a microcontroller Arduino UNO as the control unit. The motorcycle security system works when the condition is on or off because the security system will continue to run. The alarm feature in this security system is used to alert the user about the danger of riding a motorbike while drunk. Connection between the motorcycle and the helmet is done using a Bluetooth connection. The proposed security system using fingerprint and voice commands has been tested and gives good results.

REFERENCES

- [1] I. Hasan, Denur, and R. Zukriady, "Modifikasi Kunci Kontak Menggunakan Perintah Suara (Arduino Uno R3) Pada Sepeda Motor, (in Bahasa),2020.
- [2] Rahmi Eka Putri and W. Andriani, "Design of Sitting Time and Position Detection System Using Flex Sensor," 2021.
- [3] M. T. Tombeng, R. Najoan, and N. Karel, "Smart Car: Digital Controlling System Using Android Smartwatch Voice Recognition,"2019.
- [4] D.B. Tushara and P. A. H. Vardhini, "Wireless Vehicle Alert And Collision Prevention System Design Using Atmel Microcontroller",2016.
- [5] E. Jajuli, "Desain Dan Implementasi Sistem Keamanan Sepeda Motor Menggunakan Perintah Suara Dan Sensor Sidik Jari Berbasis IOT, (in Bahasa)" Univ. Islam Negeri Sunan Gunung Djati Bandung, no. July, 2022.
- [6] İskender, H. Üçgün, U. Yüzgeç, and M. Kesler, "Voice Command Controlled Mobile Vehicle Application,"2018. 9. S. Mahendra, M. Sathiyarayanan.
- [7] M. T. Tombeng, R. Najoan, and N. Karel, "Smart Car: Digital Controlling System Using Android Smartwatch Voice Recognition,"2019.
- [8] T. Noman, S. Hossain, S. Islam, M. E. Islam, N. Ahmed, and M.A. M. Chowdhury, "Design and Implementation of Microcontroller Based Anti-Theft Vehicle Security System using GPS, GSM and RFID," 2018.
- [9] E.Jajuli, "Desain Dan Implementasi Sistem Keamanan Sepeda Motor Menggunakan Perintah Suara Dan Sensor Sidik Jari Berbasis IOT, (in Bahasa)" Univ. Islam Negeri Sunan Gunung Djati Bandung, no. July, 2022.
- [10] S. Mahendra, M. Sathiyarayanan, and R. B. Vasu, "Smart Security System for Businesses Using Internet of Things (IoT)," 2018.

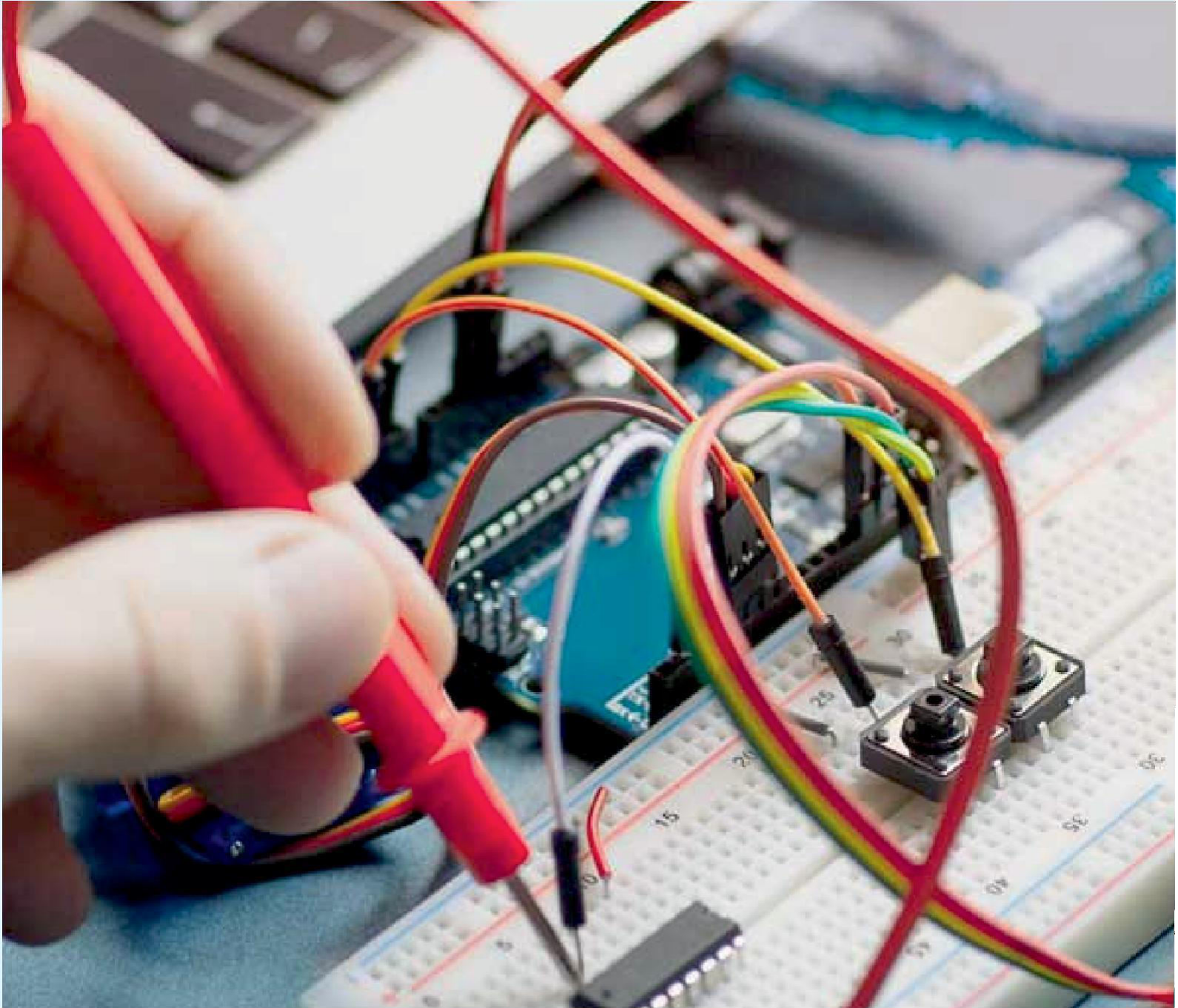

INNO  SPACE
SJIF Scientific Journal Impact Factor

 doi[®]
cross ref

 INTERNATIONAL
STANDARD
SERIAL
NUMBER
INDIA



International Journal of Advanced Research

in Electrical, Electronics and Instrumentation Engineering

 9940 572 462  6381 907 438  ijareeie@gmail.com



www.ijareeie.com

Scan to save the contact details