



e-ISSN: 2278-8875
p-ISSN: 2320-3765

International Journal of Advanced Research

in Electrical, Electronics and Instrumentation Engineering

Volume 10, Issue 1, January 2021

ISSN INTERNATIONAL
STANDARD
SERIAL
NUMBER
INDIA

Impact Factor: 7.122

9940 572 462

6381 907 438

ijareeie@gmail.com

www.ijareeie.com



A Review on Power Converters for Plug-in Electric Vehicle

Dr. N. R. Bhasme¹, Abhijeet Mohan²

Associate Professor, Dept. of EE, Government Engineering College, Aurangabad, Maharashtra, India¹

PG Student, Dept. of EE, Government Engineering College, Aurangabad, Maharashtra, India²

ABSTRACT: The predominant part of air pollution is caused by the emanation of carbon dioxide from the conventional engine. Nowadays, air pollution has become the main cause of degradation of environment, making the electric vehicle the best option to mitigate it. By comparing with conventional engine vehicles the electric vehicles have very few moving parts, good speed control, high acceleration, and high starting torque. This paper gives an idea about power converter types used for plug-in electric vehicles with their applications and comparison.

KEYWORDS: Power converters-Buck converter, Boost converter, Buck-boost converter, Cuk converter, Sepic converter, Zeta converter, Luo converter, Electric Vehicles (EVs)

I.INTRODUCTION

In the early period of automotive industry Competition between the three automotive technologies i.e. Electric Vehicles (EVs), steam cars and Internal combustion engine vehicles (ICEVs) takes place for market domination [1]. Steam cars had two major issues: they needed to be heated about 20 minutes before driving, and they required huge quantities of water causing it to disappear in 1920 from market [2]. The downsides of the ICEVs were the struggle of engine starting, the noise, the low top speed and the short range [3]. The drawback of electric vehicle (EV) was linked to poor battery performance: low top speed, limited driving range and not able to climb hills. From year 1900 onwards, a number of developments enabled ICE vehicles to enhance the top speed and range of driving, solve the problem of start-up offering a wide range of sales volume till now [4]. In today's world, due to technological advancement, environmental needs and the unavoidable decline of fossil fuels, it seems that the EV market is starting to rise. For a variety of ecological and economical factors, the EV industry is expected to have a major effect on the global automotive market.

EVs (plug-in electric vehicles) draw whole or portion of their energy from the electrical grid. Two types of EVs are,

- a) All-electric vehicles (AEVs) - It includes Battery Electric Vehicles (BEVs) and Fuel Cell Electric Vehicles (FCEVs). They collect energy by connecting it to the grid and storing it in the batteries. Most have ranges from 80 to 100 miles except for luxurious models have range upto 250 miles. When battery has been drained it can take 30 minutes for fast charging and upto 1 day for level 1 charging to recharge it.
- b) Plug-in hybrid electric vehicles (PHEVs) - It runs on electricity for shorter range from 6 to 40 miles then switched with ICE and can be used for higher ranges [5].

In vehicular Technology, the more focus shift towards the electrical system as it becomes a promising solution to restrain air pollution. The EV system comprises of batteries, power converters, electronic controllers, electric motors. As shown in Fig.1 In this system battery packs, supercapacitors, flywheels can be used to store the electricity whereas rechargeable batteries used for primary storage [6]. In recent years, the implementation of rechargeable batteries in EVs has been highly widespread. Various types of energy storage batteries, including lead acid, lithium-ion and Ni-MH have been implemented and examined for EVs [7]. Due to its long lifespan, good energy density and peak performance, lithium-ion battery is extensively used [8]. Nowadays, DC-DC converters are broadly utilized in EVs and various applications in industry. For battery charging and discharging in Plug-in EVs bidirectional DC-DC converter is employed. But the size of this converter is very large and the cost is also high and used for medium Power application compared to non-isolated converter [9]. From an economical aspect, the cost of electricity is lesser than that of fossil fuels. Some of the objectives associated with the greenhouse gas footprint, dependency upon oil, and cost have attained by consolidating EVs [10].



The global market of plug-in EVs rapidly increasing from the last five years. From the statistical aspect, around 2.2 million units of EVs were sold globally due to the initiatives taken by the governments of various countries [11].

The operation of various power converters used in plug-in EVs are studied in this paper.

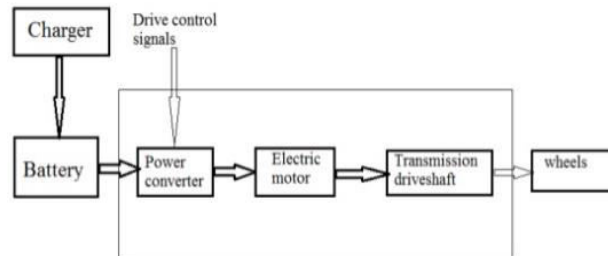

Fig.1 Electric Vehicle System

II.POWER CONVERTERS SYSTEM MODEL AND ASSUMPTIONS

The role of power converter is to regulate and process the stream of electrical energy by providing currents and voltages in manner that is suitable for the load of user. The Various types of converter used in EVs are as follows,

A. Buck converter

Also called step down converter as its steps down a DC voltage from the input side to output side. It basically operates in two modes depending on the position of a switch. It is use to send the power to the battery in EVs as well as for various loads such as sensors, safety equipments and entertainment. The circuit diagram is as shown in Fig.2

Mode 1 - When switch (Q) is ON the current starts flowing through the inductor (L) and starts charging it and source voltage (Vs) appears across the output side.

Mode 2- When Q is OFF inductor starts discharging through load and diode. It is the ability to provide less output and input ripple current [12], [13].

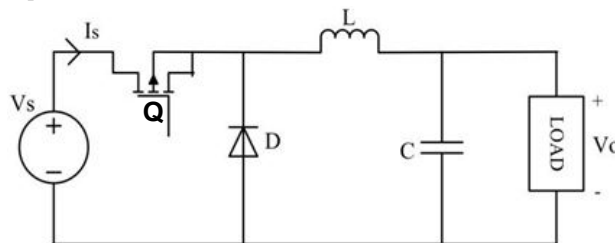

Fig.2 Buck Converter

The average output voltage is

$$V_0 = \alpha \cdot V_s$$

Where,

V_0 = output voltage

V_s = supply voltage

α = duty ratio

B. Boost converter

Also known as Step up converter as it steps up a DC voltage from the input side to output side. The circuit diagram is as shown in Fig.3The boost topology is simplified for regenerative mode for the battery charging and also used for supplying the power to I.M. in driving mode in EVs.



Mode 1- When Q is ON the current starts flowing through the L, switch and back to the source and charges the inductor. As the switch is short-circuited the output voltage becomes zero.

Mode 2- As Q is OFF the polarity of inductor reverses and starts discharging. So that we get the increased voltage at output side which is the addition of input voltage that is V_s and voltage due to inductor action [12],[13].

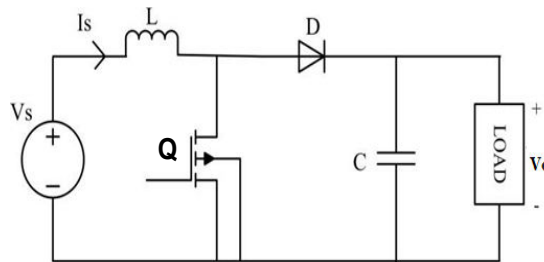

Fig.3 Boost Converter

The average output voltage is

$$V_0 = \frac{V_s}{1 - \alpha}$$

C. Buck- boost converter

Depending upon the requirement it can be used Step Up or step down. Such type of bi-directional Topology is used for regenerative braking system in EVs. The circuit diagram is as shown in Fig.4

Mode 1- When Q is ON the current starts flowing through L and back to the source. At this time the inductor starts charging.

Mode 2- When Q is OFF the L starts discharging through capacitor and load during this period diode is on and the capacitor is charged.

Mode 3- When diode D and switch is OFF, capacitor voltage appears across output which is negative so it is also called as inverting regulator [12],[13].

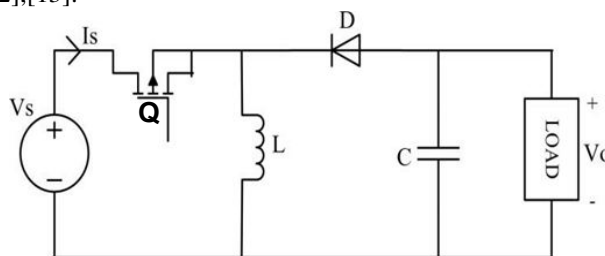

Fig.4 Buck-Boost Converter

The average output voltage is

$$V_0 = V_s \cdot \frac{\alpha}{1 - \alpha}$$

D. Cuk converter

This converter provides a buck or boost operation. It binds the good quality of buck and boost converter in terms of filtering input and output. The circuit diagram is as shown in Fig.5 the topology of cuk converter is used in charging the battery of EVs to reduce input current THD and PF improvement. It enables low voltage ripples on both sides. Energy transfer depends on capacitor C. It is an inverting type of converter. It has minimum switching losses and provides maximum power at high efficiency. An inductor providing at the output side to improve ripple-free characteristics of



output current. Output current is flowing through capacitor C_o so that the capacitor of high ripple current rating and low value of series resistance are used to reduce the losses [12],[13].

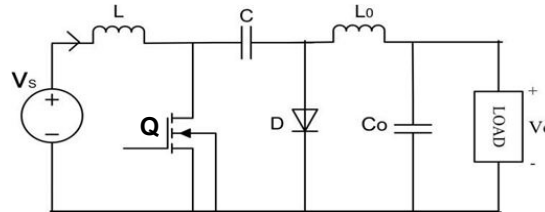

Fig.5 Cuk Converter

The average output voltage is

$$V_o = V_s \cdot \frac{\alpha}{1 - \alpha}$$

E. Sepic Converter

Sepic is a single ended primary inductor converter.

Such topology implemented for charging the battery in EVs giving low THD for input current and better efficiency.

The output voltage of this converter may be equal, greater, or less than input depending on duty cycle that controls the output voltage. If the duty cycle is above 0.5, it will step up otherwise step down. This converter is same as buck boost converter except that of non-inverting output which is one of the advantages. The circuit diagram and waveforms are as shown in Fig.6 and Fig.7

Mode 1- When Q1 is ON then L1 is charged and L2 charged via coupling capacitor where C2 maintains the output.

Mode 2- When Q1 is OFF the capacitor C2 charged by inductor L1 and L2 through the diode D. It gives lower ripples endless stress on capacitor C1. such type of converter is used where high voltage is required [12], [17].

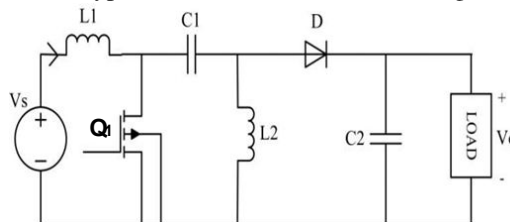

Fig.6 Sepic converter

Here, the voltage across the switch is given by V_{Q1} and current I_{Q1}

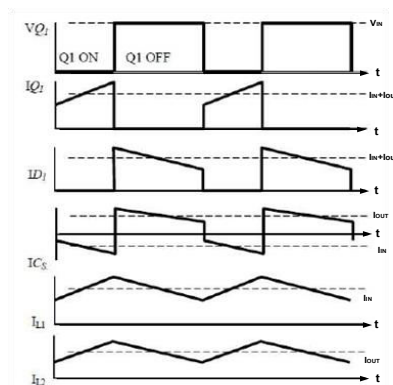

Fig.7 Switching Waveform



The average output voltage is

$$V_0 = V_s \cdot \frac{\alpha}{1 - \alpha}$$

F. Zeta converter

Zeta converter or inverse sepic built by using pair of inductors and capacitors. It is able to operating in both the mode that is either in step up or step down. This topology have lower output-voltage ripple and is easy to compensate compare to the Sepic converter and also used for power factor correction. The integrated topology of zeta-sepic converter is best suitable in EVs as it requires less components as well as better efficiency. The output voltage is positive which makes sensing circuit simple. The circuit diagram and waveforms are as shown in Fig.8 and Fig.11

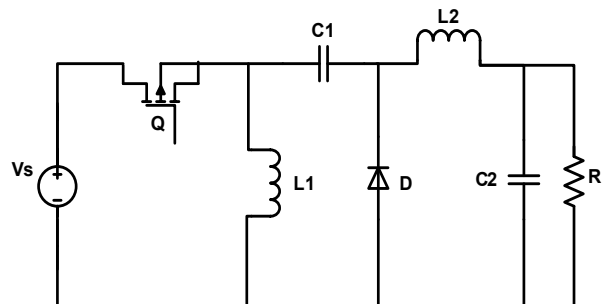

Fig.8 Zeta converter

Mode 1-When Q1 is ON as shown in Fig.9 The diode D becomes OFF. The first inductor L1 stores the energy obtained from the rectifier. The energy provided to the load (R) through L2 and C2 by the C1. The currents through the inductors L1 and L2 increase linearly. Also called charging mode.

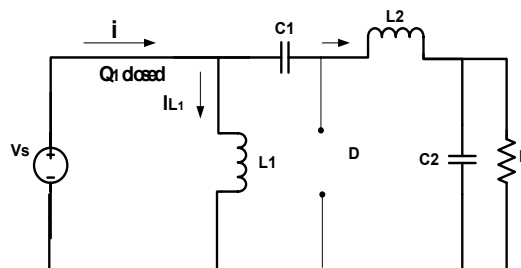

Fig.9 Equivalent circuit when switch is ON

Mode 2-When Q1 is OFF as shown in Fig.10 The diode D becomes ON as a result of the voltage across the inductor L2 has reversed polarity, the energy which is stored in the inductor L1 is transmitted to C1. The load R receives energy from L2. Also called discharging mode [13], [18].

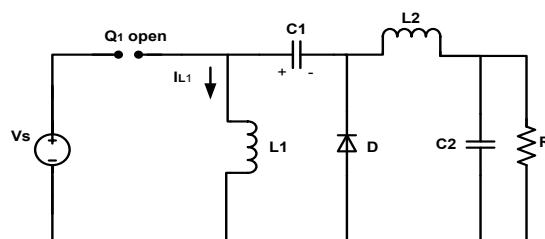

Fig.10 Equivalent circuit when switch is OFF

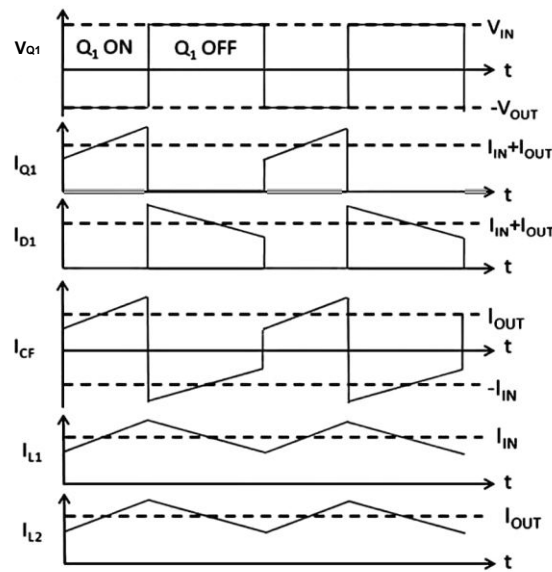

Fig.11 Switching Waveform

The average output voltage is

$$V_0 = V_s \cdot \frac{\alpha}{1 - \alpha}$$

G. Luo converter

The battery which is used in EVs provides DC voltage which is not constant and consisting of high voltage ripples. The classical buck converter contains more ripples. So Luo converter is put forward to overcome this problem in EVs. It is derived from the buck-boost converter. In such type, output ripples, enhancement of output voltage is done by additional filter which is present in this converter. The circuit diagram and waveforms are as shown in Fig.12 and Fig.15

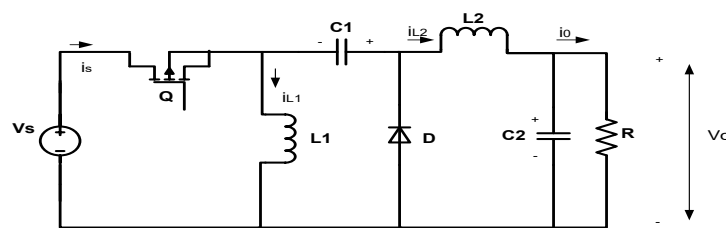

Fig.12 Luo converter

Mode 1- When Q is ON as shown in Fig.13 supply voltage Vs charges L1. Simultaneously, the energy from the C1 and voltage source is absorbed by L2.

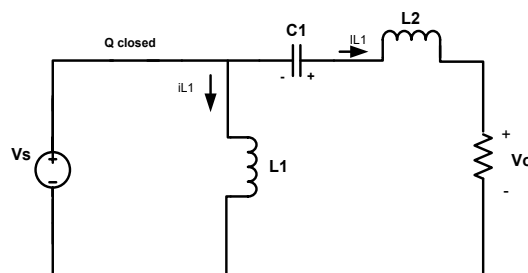

Fig.13 Equivalent circuit when switch is ON



Mode 2- When Q is OFF as shown in Fig.14 the C1 is charged by Current i_{L1} via freewheeling diode. The flow of current i_{L2} is through C2-R and D to keep itself continuous [15], [16].

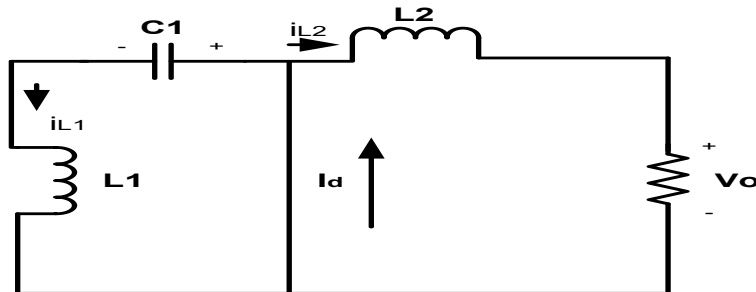

Fig.14 Equivalent circuit when switch is OFF

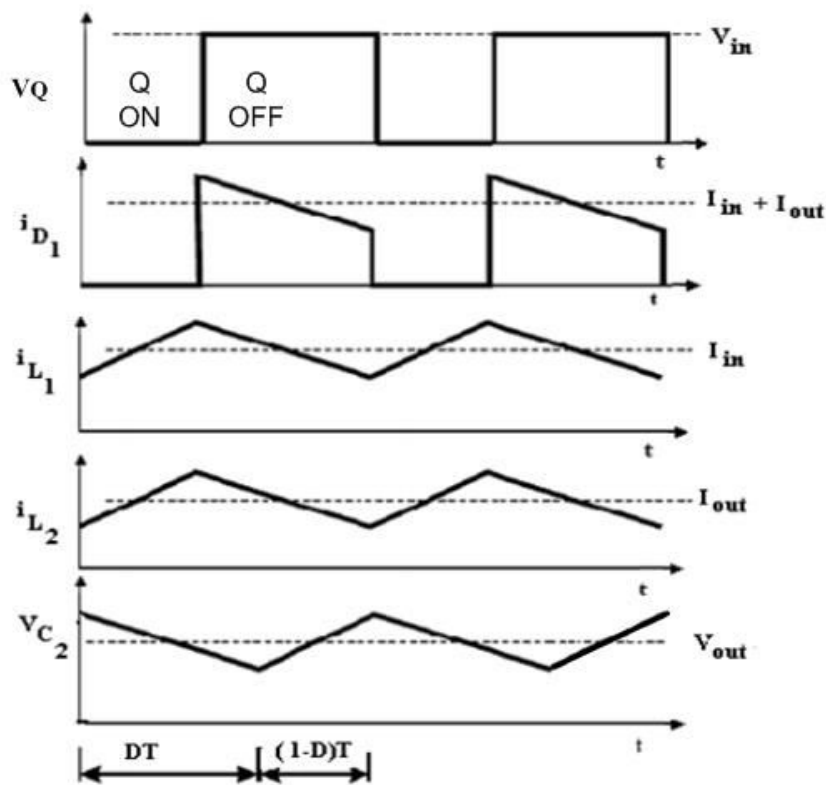

Fig.15 Switching Waveform

The average output voltage is

$$V_0 = V_s \cdot \frac{\alpha}{1 - \alpha}$$

Where,

V_0 = output voltage

V_s = supply voltage

α = duty ratio



III. CLASSIC COMPARISON OF POWER CONVERTER

TABLE 1 COMPARISON OF POWER CONVERTERS

CONVERTER	Input current	Output current	Output voltage polarity	Switch drive	Efficiency	Cost
Buck-Boost	Pulsating	Pulsating	Inverted	Floated	Low	Medium due to float drive
Cuk	Non- Pulsating	Non- Pulsating	Inverted	Floated	Medium	Medium due to additional block capacitor
Sepic	Non- Pulsating	Pulsating	Non-inverted	Grounded	Medium	Medium
Zeta	Pulsating	Non- Pulsating	Non-inverted	Floated	High	Medium
Luo	Pulsating	Non- Pulsating	Non-inverted	Floated	Medium	High

IV. APPLICATIONS IN EVS

These systems consist of isolated dc-dc converter used for Bidirectional electrical vehicular applications. For charging and discharging the additional isolation circuit is required in conventional Buck-Boost converter [14].

The voltage levels of battery consist of high ripples so it doesn't give the effective output. So the overall system ripples are reduced by the topology of Luo converter [15].

The topology of the Sepic converter is used for charging and used for step down configuration. This gives the low THD for input current and better efficiency [17].

The zeta-sepic based integrated converter is used in this topology. In which it operates in three modes: first is charging, second is propulsion and third is regenerative braking. In the first mode, it works as zeta converter and in the second as Sepic converter. It consists of the least components comparing with the existing single stage converter. And the efficiency of three modes are 95.9%, 97.1% and 96.7% respectively [18].

The boost system is simplified for regenerative charging the battery in regenerative mode and also used for supplying the power to I.M. in driving mode [19].

For power factor correction the bridgeless zeta converter is used. The isolation between output and input is given by zeta converter [20].

The topology of Cuk converter by using interleaving technique is applied as EV charger for improving power factor at AC mains and reduce the THD of input current to significant amount [21].

V. ADVANTAGES OF POWER CONVERTERS

The various advantages of power converter are,

- High efficiency due to losses are limited in semiconductor devices
- Long lifespan
- Smaller size
- It can manage high current output
- Less maintenance due to the lack of moving components
- Flexibility in operations
- Low cost of installation
- Low thermal dissipation

VI. CONCLUSION

This paper gives a brief overview of operations, comparisons, and applications of power converters implemented in EVs. The various problems associated with the power converters and their applications in the field of EVs are



identified. The battery pack performance is limited over the charging time, i.e. when the current delivered from the power converter to battery is less then, the charging time of the battery will be longer. Adaptive controller is one of the most prominent and preferred solutions in EVs to overcome the problem of battery pack charging time.

REFERENCES

- [1] Cowan R, Hulte'n S (1996) Escaping lock-in: the case of the electric vehicle. Technol Forecast Soc Change 53:61–79
- [2] McLaughlin C (1965) The fall (and possible rise) of the steam car. Steam Automobile 7:2
- [3] D'Agostino S (1993) The electric car. Potentials IEEE 12:28–32
- [4] Sulzberger C (2004) An early road warrior: electric vehicles in the early years of the automobile. IEEE Power Energy Mag 2:66–71
- [5] <https://www.energy.gov/eere/electricvehicles/electric-vehicle-basics>
- [6] J Jency Josepha, JL Julihab, Josh F.Ta, “Review on the Recent Development of the Power Converters for Electric Vehicle,” Proceedings of the 2nd International Conference on Communication and Electronics Systems (ICCES 2017) IEEE Xplore Compliant - Part Number:CFP17AWO-ART, ISBN:978-1-5090-5013-0.
- [7] Manzetti S, Mariasiu F. Electric vehicle battery technologies: from present state to future systems. Renew Sustain Energy Rev 2015;51:1004–12.
- [8] Saw LH, Ye Y, Tay AAO. Integration issues of lithium-ion battery into electric vehicles battery pack. J Clean Prod 2016; 113:1032–45.
- [9] Dakshina M. Bellur and Marian K. Kazimierczuk, “DC-DC converters for electric vehicle application.”
- [10] C. C. Chan, “The State of the Art of Electric, Hybrid, and Fuel Cell Vehicles,” Proceeding of the IEEE, vol. 95, No 4, April 2007.
- [11] <https://www.iea.org/reports/global-ev-outlook-2020>
- [12] B.K.Bose, “Modern Power Electronics and AC Drives,” Prentice Hall.
- [13] M. H. Rashid, “Power Electronics Handbook,” Elsevier Press, 2007.
- [14] Diksha S. Ramteke, Manisha B. Gaikwad , “Isolated DC-DC Converter Fed DC Motor for Bidirectional Electric Vehicular Application,” 2018 International Conference on Smart Electric Drives & Power System.
- [15] A.Manikandan, N.Vadivel, “Design And Implementation Of Luo Converter For Electric Vehicle Applications,” International Journal of Engineering Trends and Technology (IJETT) – Volume 4 Issue 10 - Oct 2013.
- [16] Senthil Raja, Kamatchi Kannan, Elangovan S, “ Control of chaos in DC-DC positive Output Luo converter using Sliding Mode Control,” International Research Journal of Engineering and Technology (IRJET) ISSN: 2395 - 0056, Volume: 03 Issue: 11 Nov -2016
- [17] Golam Sarowar, Md. Ashraful Hoque and Mohammad Ali Choudhury,
- [18] “Simulation of High Efficiency Switched Capacitor AC to DC SEPIC Converter for Improved Power Quality”, IJCSNS International Journal of Computer Science and Network Security, VOL.16 No.10, October 2016.
- [19] Ankit Kumar Singh, Mukesh Kumar Pathak, “Single-stage ZETA-SEPIC-based multifunctional integrated converter for plug-in electric vehicles”, IET Electr. Syst. Transp., 2018, Vol. 8 Iss. 2, pp. 101-111
- [20] Kasan Hemasuk, Sakorn Po-Ngam, “The Simplified Regenerative Boost Converter for Electric Vehicle Applications,” 5th International Electrical Engineering Congress, Pattaya, Thailand, 8-10 March 2017
- [21] Dr. R. Seyezhai, Vommi Nithin, P. Siva Priya, K.Vigneshwar, & Nagineni Siva Sumanth, “Design and Implementation of a Bridgeless Zeta Converter for Power Factor Correction in Hybrid Electric Vehicles,” Vol. 3 (7). PP:24-34, 2015
- [22] Radha kushwaha, Bhim Singh, “An electric vehicle battery charger with interleaved PFC Cuk Converter,” 2018 IEEE
- [23] James Larminie, John Lowry, “Electrical Vehicle Technology Explained,” John Wiley & Sons, Ltd.
- [24] Xuesong Zhou, Lei Zou ; Youjie Ma ; Zhiqiang Gao ; Yanjuan Wu ; Jinliang Yin ; Xiaoning Xu, “The current research on electric vehicle,” 2016 Chinese Control and Decision Conference (CCDC).

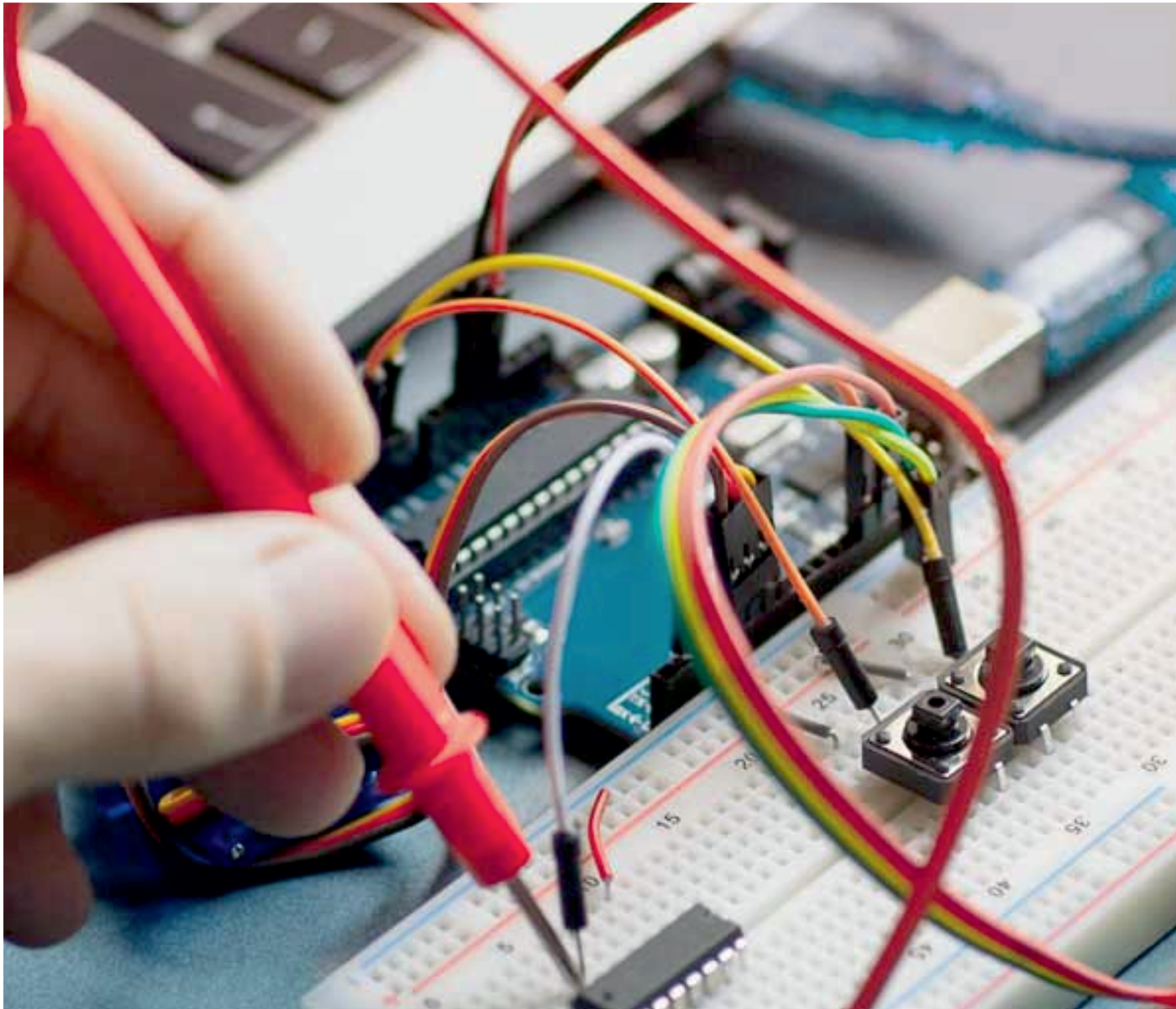

INNO  **SPACE**
SJIF Scientific Journal Impact Factor

Impact Factor:
7.122

ISSN INTERNATIONAL
STANDARD
SERIAL
NUMBER
INDIA



International Journal of Advanced Research

in Electrical, Electronics and Instrumentation Engineering

 **9940 572 462**  **6381 907 438**  **ijareeie@gmail.com**



www.ijareeie.com

Scan to save the contact details