



ISSN (Print) : 2320 – 3765  
ISSN (Online): 2278 – 8875

## International Journal of Advanced Research in Electrical, Electronics and Instrumentation Engineering

*(A High Impact Factor, Monthly, Peer Reviewed Journal)*

Website: [www.ijareeie.com](http://www.ijareeie.com)

Vol. 7, Issue 12, December 2018

# Study and Establishment of New Compact Refrigerator Container for Medical Application

Pratap Singh Thakur

Lecturer, Department of ETE, V.M.Govt. Polytechnic College, Narsinghpur, Madhya Pradesh, India

**ABSTRACT:** The paper describes efficient method to develop a portable thermoelectric refrigeration system for medical application using thermoelectric cooling effect. Thermoelectric modules are the key elements in this refrigerator for providing the thermoelectric cooling. The one side of the thermoelectric module gets cooled and provide refrigerating effect while the other side becomes hot and rejects the heat to the environment with the help of fans and fins. It will evidently reduce the burden on our ecological system by reducing the pollution caused by CFCs and other toxic components. The proposed work is validated using experimentation.

**KEYWORDS:** Refrigeration, Peltier Effect, Thermoelectric module, Portable refrigerator, etc.

### I. INTRODUCTION

Energy is vital for the progress and development of a nation's economy. Energy shortages and variable power availability is responsible for society's advancement. The systems are designed such that there will be no adverse effect on the environment. Energy saving and low environmental impact should be the primary targets for the systems designers and producers. Conventional Refrigeration and air conditioning consume enormous energy and uses Chlorofluorocarbons which causes ozone layer depletion. Solar refrigeration has been getting more and more attention. Solar refrigeration is one of the alternative technologies that use solar power in combination with peltier effect.

Thermoelectric refrigerators (TECs), also known as Peltier refrigerators. They are solid-state heat pumps that utilize the theory of Peltier effect to remove heat. When the current is passed through the terminal one side of the module absorbs the heat result in decrease in temperature produces refrigerating effect whereas other side emits the heat which provide heating effect then the heat can be dissipated to the atmosphere through forced or natural convection. The principle of peltier effect is the inverse of the principle of see back effect.

According to See back effect, when two different metals or semiconductors are kept at different temperature and both are connected at one junction then the voltage is developed on the other junction.

According to Peltier effect, It is a phenomena in which temperature difference can be measured between two different metals or semiconductors connected at one junction when the electric current is passed through the other junction.

# International Journal of Advanced Research in Electrical, Electronics and Instrumentation Engineering

(A High Impact Factor, Monthly, Peer Reviewed Journal)

Website: [www.ijareeie.com](http://www.ijareeie.com)

Vol. 7, Issue 12, December 2018

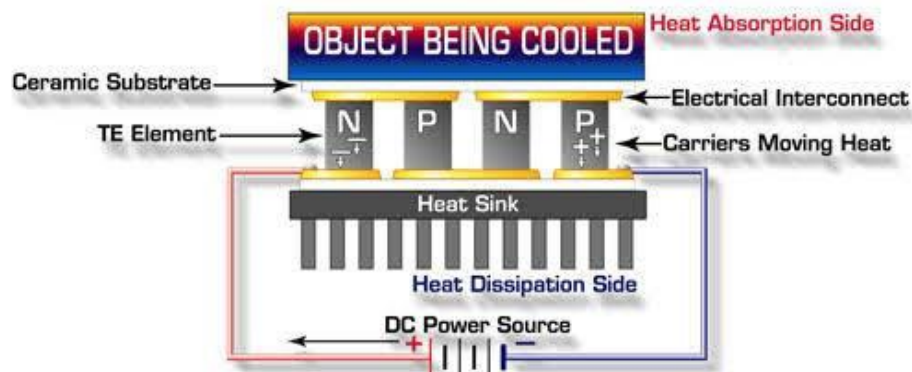

Fig 1. Principle of thermoelectric module

## II. RELATED WORK

There has been a few early-stage works concerning the optimization of TEC devices. Borislav Alexandrov has proposed a system i.e. the control principles for TEC-assisted transient cooling are presented. The control principles are implemented in a 130-nm CMOS process and co simulated with the thermal system to show their feasibility and energy overheads. The simulation results show potential for extending the time for which a chip and package can sustain a high power load [1]. Jonathan N. Davidson has proposed a work which consist technique to predict the die temperature of a MOSFET based on an empirical model derived following an offline thermal characterization [2]. Simon Lineykin proposed a work i.e. work was to develop a PSPICE-compatible equivalent circuit of a thermoelectric cooler (TEC). model is its ability to generate small-signal transfer functions that can be used to design feedback networks for temperature- control applications [3]. There are several methods of cooling electronic depending on the application. The cooling techniques can be classified broadly into two classes: (i) Passive, and (ii) Active techniques. Passive techniques can be defined as those where no external power is required for cooling where active techniques require external power to cool. There are three scales of cooling for products: (i) Module level cooling, (ii) System Cooling, and (iii) Data centre cooling. Module level cooling refers to cooling the object, system level cooling refers to the entire area and data centre cooling refers to cooling the rooms where objects and equipment are stored. The research in this project will focus on the system level cooling using peltier cooling system which involves peltier cooler modules; The components of the hybrid system along with other cooling techniques, both active and passive, adopted in object cooling are reviewed in the following sections. These works concentrate on the optimization of the physical parameters of the TEC devices. To the best of our knowledge, our work is the first attempt to systematically design the integrated TEC-based Portable Thermoelectric Refrigeration System for Medical Application and evaluate the impact of the active cooling system on the overall system.

## III. SYSTEM DEVELOPMENT

Generally Insulin injection is used to control blood sugar in people who have type 1 diabetes (condition in which the body does not make insulin and therefore cannot control the amount of sugar in the blood) or in people who have type 2 diabetes (condition in which the blood sugar is too high because the body does not produce or use insulin normally) that cannot be controlled with oral medications alone. Insulin injection is in a class of medications called hormones. Insulin injection is used to take the place of insulin that is normally produced by the body. It works by helping move sugar from the blood into other body tissues where it is used for energy. It also stops the liver from producing more sugar. All of the types of insulin that are available work in this way. The types of insulin differ only in how quickly they begin to work and how long they continue to control blood sugar. Many doctors recommended that, store unopened vials of insulin, unopened disposable dosing devices and unopened insulin pens in the refrigerator. Do not freeze insulin and do not use insulin that has been frozen. Opened vials of insulin should be stored in the refrigerator but may also be stored at room temperature, in a cool place that is away from heat and direct sunlight. Store opened

## International Journal of Advanced Research in Electrical, Electronics and Instrumentation Engineering

(A High Impact Factor, Monthly, Peer Reviewed Journal)

Website: [www.ijareeie.com](http://www.ijareeie.com)

Vol. 7, Issue 12, December 2018

insulin pens and opened dosing devices at room temperature. Otherwise it is not properly mixed with blood and also it makes pain. For that reasons we maintain the temperature of medicine by use of refrigerator. But poor people fails for the costly operation and many of the diabetes must inject the medicine 4 to 5 times. During travelling times maintain the medicine temperature is not a practical one. For the above reason the portable refrigerator is the solution for maintain medicine for the particular temperature level.

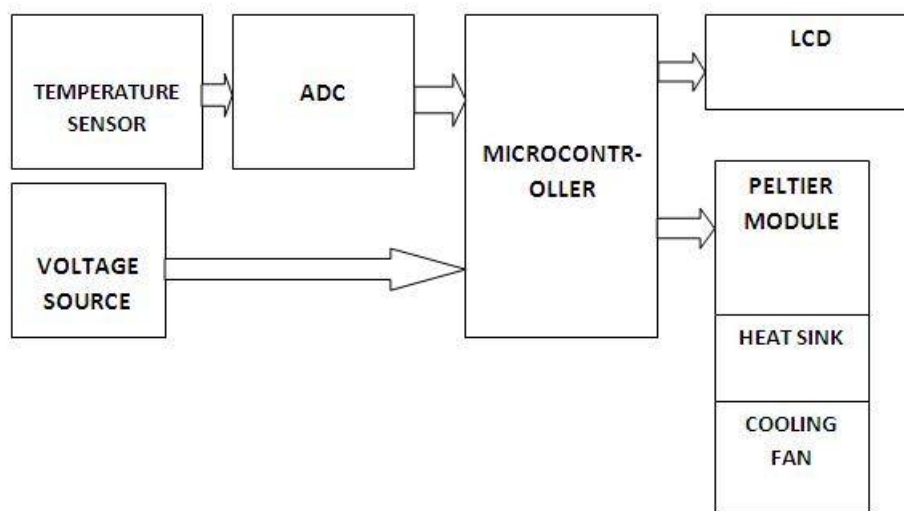

Fig 2. Block Diagram of system

Fig.2. shows the block diagram of system, which consist of temperature sensor, voltage source, analog to digital converter, microcontroller, LCD display. Microcontroller for control mechanism of peltier module, voltage control source and for LCD display. LCD display for monitoring of peltier cooling effect inside the system, current and voltage drawn from the power supply and power watt. A DC power supply system was developed to power the developed thermoelectric refrigeration cabinet for remote application where grid power is unavailable and for supply DC voltage to thermoelectric cooling modules and heat sink fan assembly of thermoelectric refrigeration cabinet. The fins attached to the hot face of the cooling unit are larger than those entering the cooled chamber. This is because the latter fins merely have to abstract heat from the chamber whereas the former have to pass this heat, as well as that developed in the thermocouples, on to the surroundings. Temperature sensor DS18B20 is a digital thermometer provides 9-bit to 12-bit Celsius temperature measurements and has an alarm function with non-volatile user-programmable upper and lower trigger points. The DS18B20 communicates over a 1-Wire bus that by definition requires only one data line (and ground) for communication with a central microprocessor. In addition, the DS18B20 can derive power directly from the data line (“parasite power”), eliminating the need for an external power supply. Each DS18B20 has a unique 64-bit serial code, which allows multiple DS18B20s to function on the same 1-Wire bus. Thus, it is simple to use one microprocessor to control many DS18B20s distributed over a large area. Applications that can benefit from this feature include HVAC environmental controls, temperature monitoring systems inside buildings, equipment, or machinery, and process monitoring and control systems. A Pulse Width Modulation (PWM) module in addition with a low pass filter circuit can produce different analogue voltages. In the proposed work, this analogue voltage is used to give set point temperature voltage. A PWM of frequency,  $FPWM = 2 \text{ KHz}$  is generated using a microcontroller Input/output port pin. A low pass filter circuit of frequency  $FLP = 5 \text{ KHz}$ , using  $R = 1\text{K}$  and  $C = 1\mu\text{F}$ , gives a good quality set point temperature voltage. The basic principal of the proposed system is based on reverse of see-back effect and is known as Peltier effect. A peltier element consists of a heat conducting material along with two wires, if the flow of current is reversed through the wires, then the sides of the peltier device show the reverse temperature effect. Peltier elements have further features; It is in solid state; Need no maintenance, long service life-time. Peltier element has applications in deep space probes, microprocessor cooling, laser diode temperature stabilization, temperature regulated flight suits and air conditioning in submarines, Portable DC refrigerators, and automotive seat cooling/heating.



## International Journal of Advanced Research in Electrical, Electronics and Instrumentation Engineering

(A High Impact Factor, Monthly, Peer Reviewed Journal)

Website: [www.ijareeie.com](http://www.ijareeie.com)

Vol. 7, Issue 12, December 2018

### A. Principles of operation

Five energy-conversion processes take place in a thermoelectric module: conductive heat transfer, Joule heating, Peltier Cooling/heating, Seebeck power generation and the Thomson phenomenon. All these processes account for the interrelations between thermal and electrical energies. Following the first law of thermodynamics, one can express the energy equilibrium at both sides of the thermoelectric module that are defined as the absorbing (a) and emitting (e) junctions. For the absorbing side The performances equations (1-5) of a thermoelectric cooler are expressed as follows and are described in many handbooks and papers [3].

$$q_a = \frac{\Delta T}{\theta_m} + a_m T_a I - \frac{I^2 R_m}{2} \quad (1)$$

For the emitting side

$$q_e = \frac{\Delta T}{\theta_m} + a_m T_e I + \frac{I^2 R_m}{2} \quad (2)$$

$$\alpha_m = \alpha \times N \quad (3)$$

$$R_m = RN \quad (4)$$

$$\theta_m = \frac{\theta}{N} \quad (5)$$

Where  $q_a$  is heat absorbed at the a-side,  $q_e$  heat emitted at the e-side,  $N$  is the number of couples,  $T_a$  and  $T_e$  are the temperatures of the (a-) and (e-) sides in °C,  $\theta$  is the thermal resistance of the couple in the direction of the heat flow,  $R$  is the electrical resistance of the couple,  $\alpha$  Seebeck coefficient, and  $\Delta T = (T_e - T_a)$ . It is conventional to leave out the effect of the Thomson phenomena because it is negligibly small. The electrical part of the module is described as an electrical resistance  $R_m$  and an electrical potential difference  $V$ , as follows [3]:

$$V = a_m T_e - \alpha_m T_a = \alpha_m \Delta T. \quad (6)$$



# International Journal of Advanced Research in Electrical, Electronics and Instrumentation Engineering

(A High Impact Factor, Monthly, Peer Reviewed Journal)

Website: [www.ijareeie.com](http://www.ijareeie.com)

Vol. 7, Issue 12, December 2018

## IV. PERFORMANCE ANALYSIS

### A. calculation of the parameters of the model from manufacturers' datasheets

Manufacturers of TECs (Hebei I. T [8] and others) use the following parameters to specify their product:  $\Delta T_{max}$  is the largest temperature differential(°C) that can be obtained between the hot and cold ceramic plates of a TEC for a given level of  $T_h$  (temperature of the hot side),  $I_{max}$  is the input current (A) which will produce the maximum possible  $\Delta T$  across a TEM,  $V_{max}$  is the dc voltage (V) that will deliver the maximum possible  $\Delta T$  at the supplied  $I_{max}$ ,  $Q_{max}$  is the maximum amount of heat (W) that can be absorbed at the TEC's cold plate at  $I_{max}$  and at a  $\Delta T$  equal to 0. Note that  $Q_{max}$  is not the maximum possible amount of heat that can be handled by the TEC, rather the heat flow corresponding to the current  $I_{max}$ .  $Q_{opt}$  is the maximum amount of heat that can be absorbed at the TEC's cold plate for a  $\Delta T$  equal to 0.  $Q_{opt}$  is larger than  $Q_{max}$ . Some manufacturers apply the notation  $Q_{max}$  instead of  $Q_{opt}$ , so one needs to carefully read the description given in the datasheets[8].

Using the relations (1), (2), and (6), the characteristic parameters of the TEC can be derived as follows [3]:

$$\Delta T_{max} = T_h + \frac{(1 - \sqrt{1 + 2T_h Z})}{Z} \quad (7)$$

$$I_{max} = \frac{(1 + \sqrt{1 + 2T_h Z}) - 1}{\alpha_m \theta_m} \quad (8)$$

$$V_{max} = \alpha_m T_h \quad (9)$$

$$Q_{max} = \frac{\sqrt{1 + 2T_h Z} (1 + \sqrt{1 + 2T_h Z} - 1)^2}{2\theta_m Z} \quad (10)$$

## V. CONCLUSION

The portable refrigerator has no moving parts fluid, or refrigerants. In particular, its size is very small so it is convenient for travelers to store the medicine. Temperature was controllable via changing the input voltage/current so we can maintain the medicine as desired level of temperature and the cost of the device is very low. This system

$$I_{opt} = \frac{\alpha_m T_h}{R_m} \quad (11)$$

$$Q_{opt} = \frac{\alpha_m^2 T_h^2}{2R_m} \quad (12)$$

Where  $Z$  is a figure of merit of the TEC,  $Z = \text{mm}/R_m$ , [K-1]. Applying (7)–(12), one can now use the set of data  $T_h, \Delta T, V_{max}, I_{max}$  for calculating the parameters of the proposed model [3].

$$R_m = \frac{V_{max} (T_h - \Delta T_{max})}{I_{max} T_h} [\Omega] \quad (13)$$

$$\theta_m = \frac{\Delta T_{max}}{I_{max} V_{max}} \frac{2T_h}{(T_h - \Delta T_{max})} \left[ \frac{C}{W} \right] \quad (14)$$

$$\alpha_m = \frac{V_{max}}{T_h} \left[ \frac{V}{C} \right] \quad (15)$$

achieves 40% to 60% of cooling effect compare to conventional refrigerator. For the above reasons this is most effective for poor people (by the cost) and travelling people (because of size).



ISSN (Print) : 2320 – 3765  
ISSN (Online): 2278 – 8875

# International Journal of Advanced Research in Electrical, Electronics and Instrumentation Engineering

*(A High Impact Factor, Monthly, Peer Reviewed Journal)*

Website: [www.ijareeie.com](http://www.ijareeie.com)

**Vol. 7, Issue 12, December 2018**

## REFERENCES

1. Borislav Alexandrov, Sudhakar Yalamanchili and Saibal Mukhopadhyay “Control Principles and On-Chip Circuits for Active Cooling Using Integrated Superlattice-Based Thin-Film Thermoelectric Devices” IEEE TRANSACTIONS ON VERY LARGE SCALE INTEGRATION (VLSI) SYSTEMS, VOL. 22, NO. 9, SEPTEMBER 2014
2. Jonathan N. Davidson, David A. Stone, Martin P. Foster, and Daniel T. Gladwin “Measurement and Characterization Technique for Real-Time Die Temperature Prediction of MOSFET-Based Power Electronics” IEEE TRANSACTIONS ON POWER ELECTRONICS, VOL. 31, NO. 6, JUNE 2016
3. Simon Lineykin and Sam Ben-Yaakov “Analysis of Thermoelectric Coolers by a Spice-Compatible Equivalent-Circuit Model” IEEE POWER ELECTRONICS LETTERS, VOL. 3, NO. 2, JUNE 2005
4. Rupert Gouws\* and Houston Eilers “A review on thermoelectric cooling modules: Installation design, performance and efficiency” Vol. 8(12), pp. 485-492, 4 April, 2013 DOI 10.5897/SREX12. 001 ISSN 1992-2248 © 2013 Academic Journals
5. Abinav Pathak and Vikas Goel “HEAT PUMP DESIGN USING PELTIER ELEMENT FOR TEMPERATURE CONTROL OF THE FLOW CELL” International Journal of Computer Science, Engineering and Applications (IJCEA) Vol.3, No.3, June 2013
6. Mr. Govendra Sherkar, Mr. Amit Akkewar “To Analysis and Improvement of System Efficiency by Using Thermoelectric Device” International Journal of Research in Advent Technology (E-ISSN: 2321-9637) Special Issue 1st International Conference on Advent Trends in Engineering, Science and Technology “ICATEST 2015”, 08 March 2015
7. Ms. Anchali Patankar and Prof. Sandeep Mahajan “ Review Paper on Efficiency Improvement of Photovoltaic Panel by using Thermoelectric Effect” IJSRD - International Journal for Scientific Research & Development| Vol. 2, Issue 12, 2015 | ISSN (online): 2321-0613
8. Hebei I.T. (Shanghai) Co., Ltd, Thermoelectric Cooler datasheet.
9. TYN616 datasheet, [www.st.com](http://www.st.com)
10. DS18B20 digital thermometer Maxim Integrated Products, Inc, [www.maximintegrated.com](http://www.maximintegrated.com)
11. ACS712 Fully Integrated, Hall Effect-Based Linear Current Sensor IC with 2.1 kVRMS Isolation and a Low-Resistance Current Conductor Allegro MicroSystems, LLC, [www.allegromicro.com](http://www.allegromicro.com)
12. Power MOSFET IRFZ44, SiHFZ44 Vishay Siliconix, [www.vishay.com/doc?91000](http://www.vishay.com/doc?91000)
13. IR2112(-1-2)(S)PbF HIGH AND LOW SIDE DRIVER Data Sheet No. PD60026 revS [www.irf.com](http://www.irf.com)
14. ATmega48A/PA/88A/PA/168A/PA/328/P [DATASHEET SUMMARY]
15. MC78XX/LM78XX/MC78XXA 3-Terminal 1A Positive Voltage Regulator, [www.fairchildsemi.com](http://www.fairchildsemi.com)