



ISSN (Print) : 2320 – 3765
ISSN (Online): 2278 – 8875

International Journal of Advanced Research in Electrical, Electronics and Instrumentation Engineering

(A High Impact Factor, Monthly, Peer Reviewed Journal)

Website: www.ijareeie.com

Vol. 6, Issue 10, October 2017

A Novel Method of Resonant Converter with Multilevel Inverter for Reduction of Harmonics

P.Vinnarasi Ponnury¹, S.Priya²

Assistant Professor, Dept. of EEE, Jeppiaar Institute of Technology, Sreperumbudur, Tamilnadu, India¹

ABSTRACT: In the last few decades, various research studies have been performed to improve the switch transition to overcome this inherent problem of hard-switching PWM converters. By solving these high voltage and current stress problems, energy conversions using resonant converters have been important in ensuring both high performance and supporting energy conservation applications in renewable energy generation systems. The purpose of this paper is to design and analysis of modular multilevel converter for solar PV based system. The modular concept the application to be extended for wide power range. This study makes an attempt and verifies that the MMC system with low total harmonic distortion, unity power factor and high efficiency using soft switching methodology.

KEYWORDS : MMC, Soft Switching, ZVS and THD

I. INTRODUCTION

Resonant converters are extensively utilized in the application of renewable energy generation systems. The basic requirements of resonant converters are their small size and high efficiency. A high switching frequency is required to achieve small size. However, the switching loss increases with the switching frequency, reducing the efficiency of the resonant converters. To solve this problem, some soft-switching approaches must be used at high switching frequencies. Zero voltage switching (ZVS) and zero-current switching (ZCS) techniques are two commonly used soft-switching methods. This project proposes a dc power supply system to give high power factor and low current distortion on the rectifier side and provide stable dc voltage on the isolated dc/dc converter side. The proposed dc power supply system uses a new zero-voltage switching (ZVS) strategy to get ZVS function. Besides operating at high switching frequency, all semiconductor devices operate at soft switching. A significant reduction in the conduction losses is achieved, since the circulating current for the soft-switching flows only through the auxiliary circuit and a minimum number of switching devices are involved in the circulating current path and the rectifier in the proposed dc power supply system uses a single converter instead of the conventional configuration composed of a four-diode front-end rectifier followed by a boost converter. An average current-mode control is employed in proposed dc power supply system to detect the transition time and synthesize a suitable low harmonics sinusoidal waveform for the input current.

II. EXISTING SYSTEM

This existing system presents a new form of MMC for high-voltage step-down unidirectional dc–dc conversion. The proposed converter has inherent-balancing of each capacitor voltage. High step-down voltage conversion ratios can be achieved by using large numbers of sub modules. With phase-shifted pulse width-modulation (PWM), higher operating frequency can also be achieved, which is equivalent to the product of the number of sub modules and the switching frequency. Moreover, the converter operates with two resonant frequencies where zero voltage-switching (ZVS) and/or zero-current-switching (ZCS) become possible. The proposed converters are more suitable for low-power dc–dc applications as it has the feature of modularity, simplicity, and flexibility. The detailed



International Journal of Advanced Research in Electrical, Electronics and Instrumentation Engineering

(A High Impact Factor, Monthly, Peer Reviewed Journal)

Website: www.ijareeie.com

Vol. 6, Issue 10, October 2017

configuration and operation principle are presented, and verified by experimental results from bench-scale prototype tests.

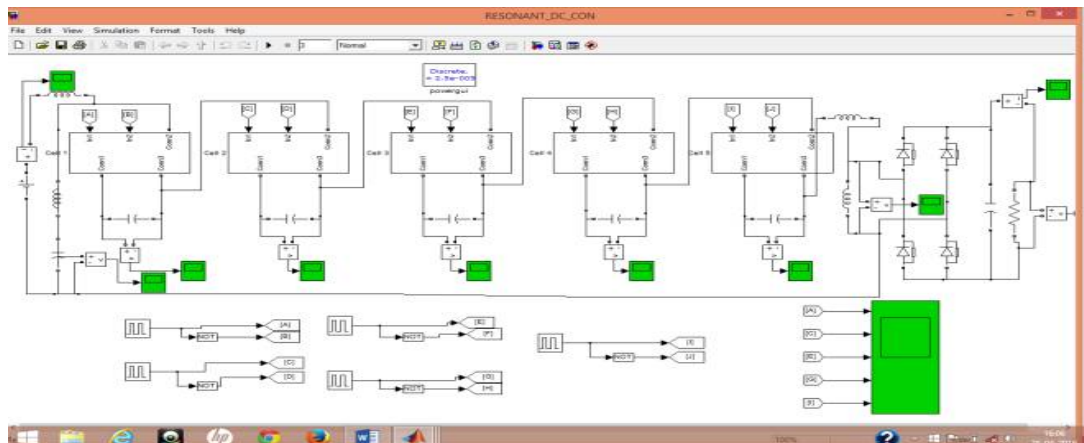

Fig 1: The Simulink model of Existing system

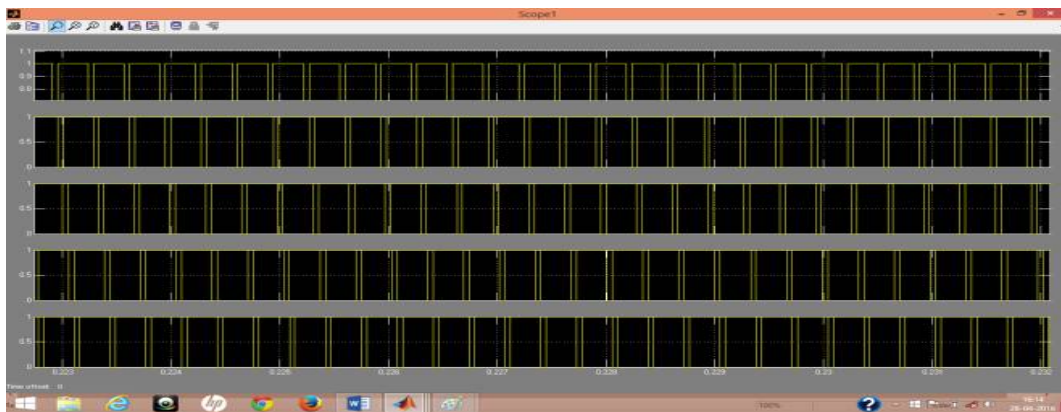

Fig 2: Switching sequence waveform

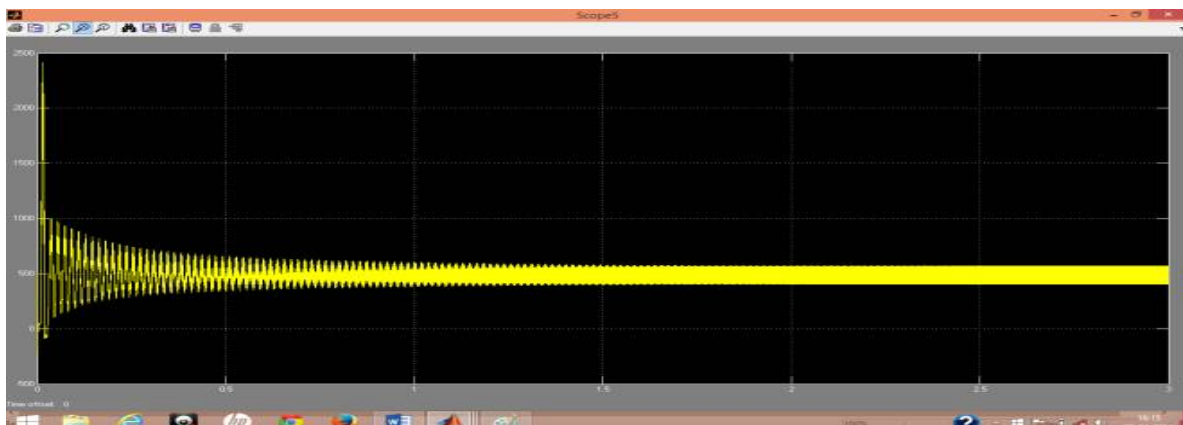

Fig 3: input Voltage Waveform



ISSN (Print) : 2320 – 3765
ISSN (Online): 2278 – 8875

International Journal of Advanced Research in Electrical, Electronics and Instrumentation Engineering

(A High Impact Factor, Monthly, Peer Reviewed Journal)

Website: www.ijareeie.com

Vol. 6, Issue 10, October 2017

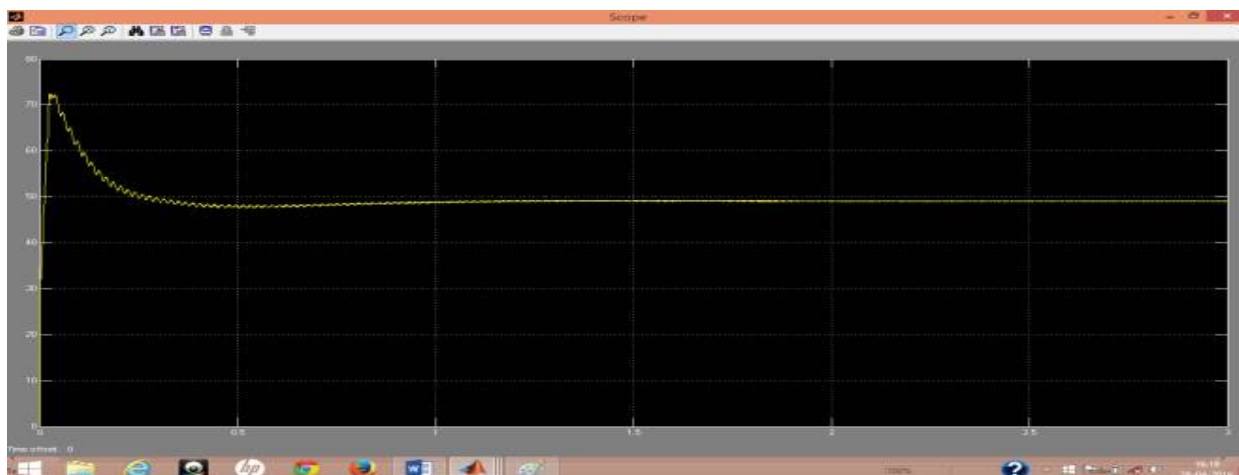

Fig 4: Output Voltage Waveform

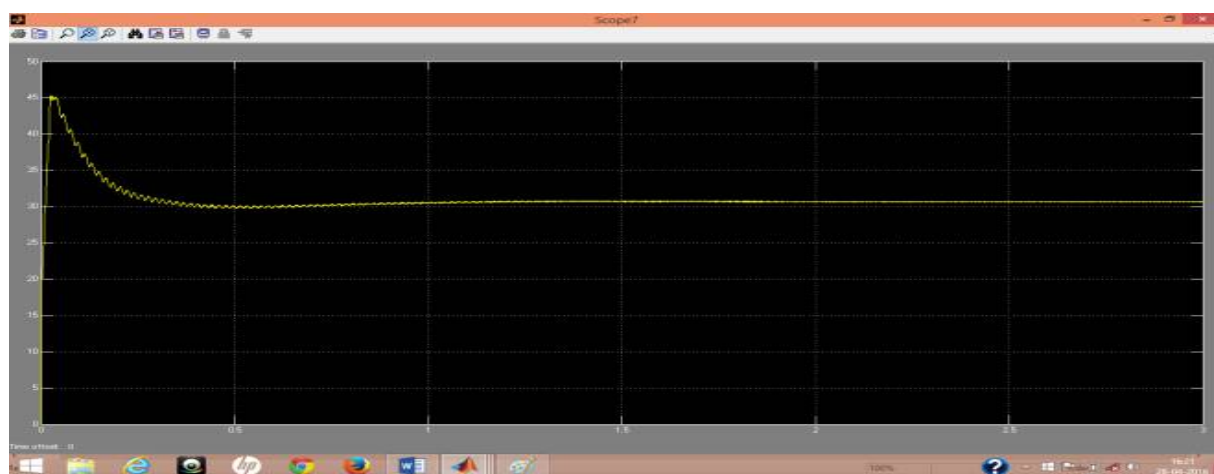

Fig 5: Output Current Waveform

III. PROPOSED METHOD

Dc power supplies have been widely used in industrial equipments, such as dc uninterruptible power supply and telecommunications power supply, and high power factor and low input-current harmonics are mandatory performances of the dc power supplies for satisfied agency standards such as EN61000–3-2. The size of low-frequency inductors and capacitors will result in the dc power supplies, which are very bulky and heavy. The passive filter approach to PFC is limited to applications where the size and weight of the converter are not major concerns.

Thus, a boost PFC front-end converter followed by a full-bridge transformer-isolated dc/dc converter is the most popularly used in offline dc power supplies. For solving the problem that the boost rectifier and the full-bridge transformer-isolated dc/dc converter must use individual soft-switching techniques to reduce their switching losses, a simple ZVS strategy is also proposed in this paper using solar power.



International Journal of Advanced Research in Electrical, Electronics and Instrumentation Engineering

(A High Impact Factor, Monthly, Peer Reviewed Journal)

Website: www.ijareeie.com

Vol. 6, Issue 10, October 2017

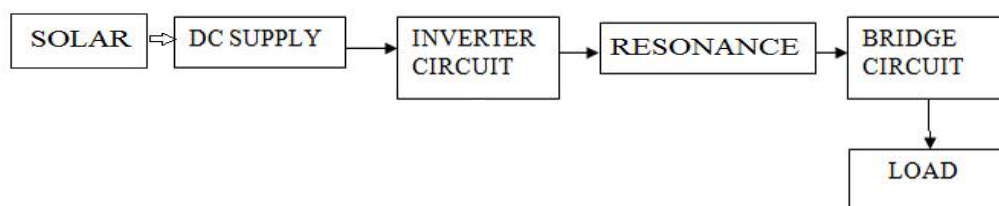

Fig 6:Proposed block diagram

In this block diagram, switches in the inverter circuit are triggered by the gate pulses. Four MOSFET switches are used in the inverter circuit. The gate pulses are given to the switches from the drive circuit. Using micro-controller 89s52 , drive circuit is actuated to give trigger pulses which will make the switches to conduct. DC supply is given to the inverter circuit so that the AC output of inverter is given to a Ferrite core transformer and then to the bridge rectifier. The boosted up voltage is supplied to the load finally. The voltage is boosted up using resonant switching at very high frequencies say 20 kHz.

IV. MMC OPERATION

In the above two approaches, the modification is realized in control circuit of CMLI to achieve 15 and 27 levels with three inverter stages. In this approach, the modification is made in both control circuit and predominately in power circuit to obtain 31 level switch only eight switches. The addition of **diode and capacitor** (1nF) is to **normalize the output** with in the given interval. Based on the table, the inverter circuit (T1–T4) is in ON condition at all the levels, but the input switches (S1–S3) are controlled in such away that to obtain the required output voltage. Let the PV array inputs be V1–V3. During the level 1, V1 alone is given as input to the inverter and V2, V3 In OFF condition. Similarly the 15 level is achieved by controlling the ON/OFF status of the input voltages. The remaining 15 level from the truth table will be obtained by controlling the sequence in reverse direction.

sw	0	1	2	3	4	5	6	7	8	9	10	11	12	13	14	15
S1	0	1	0	1	0	1	0	1	0	1	0	1	0	1	0	1
S2	0	0	1	1	0	0	1	1	0	0	1	1	0	0	1	1
S3	0	0	0	0	1	1	1	1	0	0	0	0	1	1	1	1
S4	0	0	0	0	0	0	0	0	1	1	1	1	1	1	1	1
S5	0	1	1	1	1	1	1	1	1	1	1	1	1	1	1	1
S6	0	0	0	0	0	0	0	0	0	0	0	0	0	0	0	0
S7	0	0	0	0	0	0	0	0	0	0	0	0	0	0	0	0
S8	0	1	1	1	1	1	1	1	1	1	1	1	1	1	1	1

Fig 7:Switching sequence of MMC

V. DESIGN OVERVIEW

The control strategy used in resonant converter switching is explained. Soft switching technique is used in this proposed method which helps in reducing the switching losses. The circuit is operated with ZVS topology and the measured energy conversion is about 11% more than conventional method.

International Journal of Advanced Research in Electrical, Electronics and Instrumentation Engineering

(A High Impact Factor, Monthly, Peer Reviewed Journal)

Website: www.ijareeie.com

Vol. 6, Issue 10, October 2017

Simulation results and discussion are explained. The results are explained as waveform and compared with the conventional method for efficiency. Thus in proposed method the efficiency is increased. The proposed dc power supply system must control both the input current and the output voltage. The input current of proposed dc power supply system must be programmed to follow line input voltage and to be the shape of line input voltage. Thus, the average-current mode is used to control the input current. The output voltage is controlled by changing the average amplitude of the current-programming signal. The block diagram of the proposed soft switching single-phase dc power supply system with average current mode. The controller can prescribe the shape and the frequency of the input current due to its inherently synchronous feedback loop.

In order to obtain almost unity power factor, the synchronous signal must be sensed from a rectified line input voltage. The analog multiplier creates the current programming signal by multiplying the rectified line voltage with the error output voltage between the feedback voltage and the reference voltage V_{ref} so that the current-programming signal has the shape of the line input voltage and an average amplitude to control the output voltage. The error output voltage between the feedback voltage and reference voltage V_{ref} is divided by square of the average input voltage before it is multiplied by the rectified input voltage signal. It can keep the gain of the voltage loop composed

VII. SIMULATION CIRCUIT OF 15 LEVEL RESONANT CONVERTER

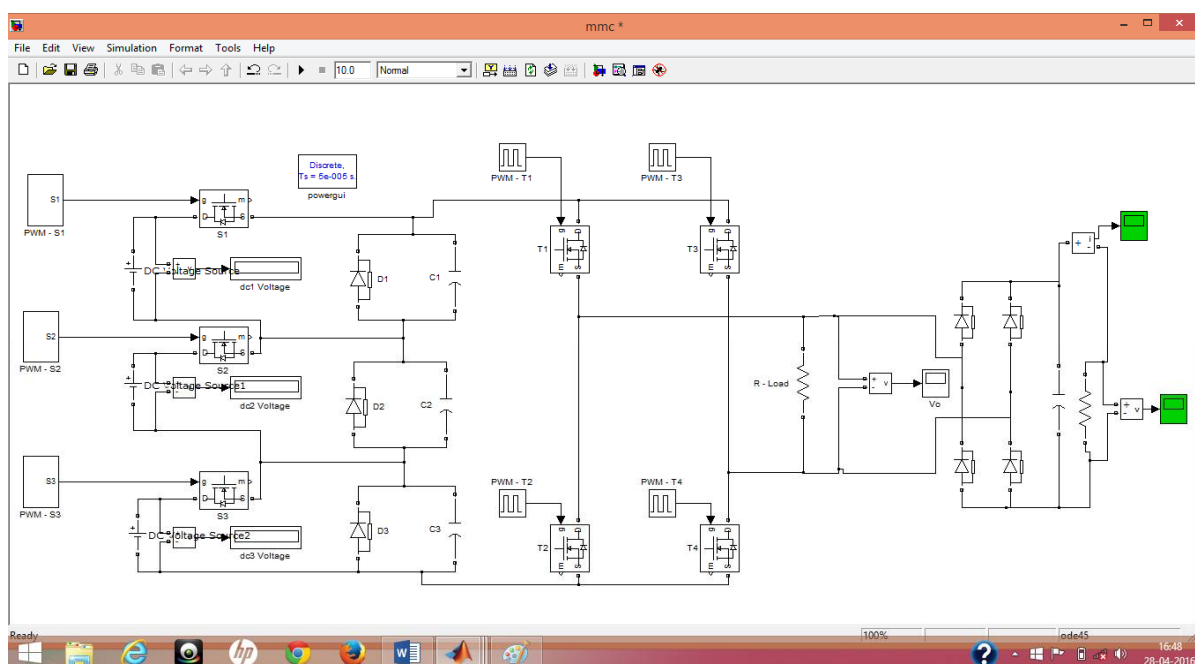

Fig 8: Simulation Circuit Of 15 Level Resonant MMC Dc Converter



ISSN (Print) : 2320 – 3765
ISSN (Online): 2278 – 8875

International Journal of Advanced Research in Electrical, Electronics and Instrumentation Engineering

(A High Impact Factor, Monthly, Peer Reviewed Journal)

Website: www.ijareeie.com

Vol. 6, Issue 10, October 2017

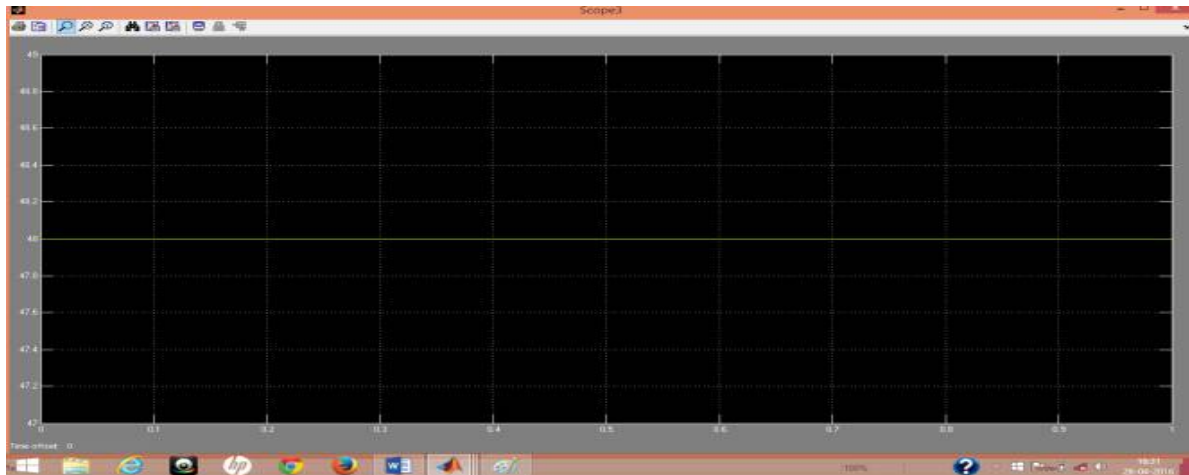

FIG 9:INPUT VOLTAGE V_{o1} waveform



FIG 10:OUTPUT VOLTAGE OF CONVERTER waveform

ADVANTAGES

- Reduce the switching loss.
- High efficiency.
- Reduced THD
- Reduced number of switches

APPLICATIONS

- Industrial machines, Airplanes.
- Automobiles medical equipment.
- House hold appliances, High power applications.



ISSN (Print) : 2320 – 3765
ISSN (Online): 2278 – 8875

International Journal of Advanced Research in Electrical, Electronics and Instrumentation Engineering

(A High Impact Factor, Monthly, Peer Reviewed Journal)

Website: www.ijareeie.com

Vol. 6, Issue 10, October 2017

VII. CONCLUSION AND FUTURE SCOPE

The proposed work demonstrated the state of art switched resonant converter technology. A novel method for soft switching was investigated in order to improve the efficiency of PV systems. The design and simulation of a ZVS based switched resonant converter was proposed using MATLAB. The proposed method has very good performances, fast responses with no overshoot and less fluctuation in the steady state. These controllers are able to attain an increase in the output voltage level based on the increase in the switching frequency which would drastically improve the performance of the system. Intensive literature survey has done on various maximum resonant switching and it could be used drastically to improve the efficiency of a solar PV system. Also found that ZVS is most efficient and there is an increase in the output voltage which could be utilized in various applications for future in order to save energy.

REFERENCES

- [1] A Half-Bridge LLC Resonant Converter Adopting Boost PWM Control Scheme for Hold-Up State Operation. In-Ho Cho, Student Member, IEEE, Young-Do Kim, Student Member, IEEE, and Gun-Woo Moon*, Member, IEEE. International journal of scientific and research publications, Volume :3,ISS :5,FEB 2014.
- [2] W. Chen, X. Ruan, and R. Zhang, —A novel zero-voltage-switching PWM full bridge converter, IEEE Trans. Power Electronics., vol. 23, no. 2, pp. 793– 801, Mar. 2008.
- [3] M. Borage, S. Tiwari, S. Bhardwaj, and S. Kotaiah, —A full-bridge DC—DC converter with zero-voltage-switching over the entire conversion range, IEEE Trans. Power Electron., vol.23,no.4,pp.1743–1750,Mar. 2008.
- [4] C. Yan, H. Wu, J. Zeng, Y. Jianping, and J. Tan, —A precise ZVS range calculation method for full bridge converter, in Proc. IEEE Power Electron. Spec. Conf., 2003, pp. 1832–1836.
- [5] J.-R. Tsai, T.-F. Wu, C.-Y. Wu, Y.-M. Chen, and M.-C. Lee, —Interleaving phase shifters for critical-mode boost pfc, IEEE Trans. Power Electron., vol. 23, no. 3, pp. 1348–1357, May 2008.
- [6] C. M. Wang, —A new single-phase ZCS-PWM boost rectifier with high power factor and low conduction losses, IEEE Trans. Ind. Electron., vol. 53, no. 2, pp. 500–510, Apr. 2006.
- [7] C.M.Wang, —A novel ZCS-PWM power factor pre-regulator with reduced conduction losses, IEEE Trans. Ind. Electron., vol. 52, no. 3, pp. 689– 700, Jun. 2005.
- [8] C. M. Wang, —A novel zero-voltage-switching PWM boost rectifier with high power factor and low conduction losses, IEEE Trans. Ind. Electron., vol. 52, no. 2, pp. 427–435, Apr. 2005.
- [9] H. M. Suryawanshi, M. R. Ramteke, K. L. Thakre, and V. B. Borghate, —Unity-Power-Factor operation of three-phase AC–DC soft switched converter based on boost active clamp topology in modular approach, IEEE Trans. Power Electron., vol. 23, no. 1, pp. 229–236, Jan. 2008.
- [10] Y. Jang, D. L. Dillman, and M. M. Jovanovic, —A new soft-switched PFC boost rectifier with integrated fly back converter for stand-by power, IEEE Trans. Power Electron., vol. 21, no. 1, pp. 66–72, Jan. 2006.
- [11] D. D.-C. Lu, H. H.-C. Lu, and V. Pjevalica, —A single-stage AC/DC converter with high power factor, regulated bus voltage, and output voltage, IEEE Trans. Power Electron., vol. 23, no. 1, pp. 218–228, Jan. 2008.
- [12] Y. Jang, M. M. Jovanovic, and D. L. Dillman, —Soft-Switched PFC boost rectifier with integrated ZVS two-switch forward converter, IEEE Trans. Power Electron., vol. 21, no. 6, pp. 1600–1606, Nov. 2006.