



# **A Multifunctional D-STATCOM for Compensation of Harmonics and Reactive Power in Induction Motor Drive**

Baratam Murali<sup>1</sup>, Budi Srinivasarao<sup>2</sup>

PG Student, Dept. of EEE, Sri Sivani College of Engineering, Chilakapalem, Srikakulam (Dt); A.P, India<sup>1</sup>.

Assistant Professor, Dept. of EEE, Sri Sivani College of Engineering, Chilakapalem, Srikakulam (Dt); A.P, India<sup>2</sup>.

**ABSTRACT:** In this project a Multifunctional D-STATCOM is used for the compensation of harmonics and reactive power in an Induction Motor Drive is presented. The distribution static compensator is a shunt active filter, which injects currents into the point of common coupling (PCC) (the common point where load, source, and DSTATCOM are connected) such that the harmonic filtering, power factor correction, and load balancing can be achieved. Consequently, DSTATCOM injects reactive and harmonic components of load currents to make source power factor unity. DSTATCOM can mitigate several power quality (PQ) problems, depending upon the mode of operation in both current control mode (CCM) and voltage control mode (VCM). A DSTATCOM connected at the load terminal provides voltage regulation at the load terminal during voltage disturbances and protects induction machine drive. Advantages of induction motors are that they are robust and can operate in any environmental condition Induction motors are simple and rugged in construction. maintenance free, cheaper in cost due to the absence of brushes, commutators, and slip rings and induction motors make them more prominent in industrial and domestic applications. By using Multifunctional D-STATCOM harmonics and reactive power components are reduced to a certain quantity, the Induction motor stator current speed and torque responses are improved it can be shown by using MATLAB/SIMULINK platform.

**KEYWORDS:** Distribution static compensator (DSTATCOM), multifunctional, power factor, stiff source, voltage regulation, Induction Motor.

## **I. INTRODUCTION**

The rapidly developing power electronics technology provides an opportunity for developing new power equipment for improving the performance of the power system. Flexible AC Transmission System technology (FACTS) uses the latest power electronic devices and methods to control electronically the high-voltage side of the network [1]. FACTS devices can be used for power flow control, voltage regulation, transient stability improvement, and damping of power oscillations. FACTS devices can be of shunt or series or combination of shunt and series types [2]. The shunt devices can be used for voltage regulations, while series devices can be used for regulation of line impedance and series-parallel combination can be used for real and reactive power compensation in addition to regulation of voltage and regulation of line impedance [3]. The load compensation using state feedback control of DSTATCOM with shunt filter capacitor gives better results [4]. The switching frequency components in the terminal voltages and source currents are eliminated by using state feedback control of shunt filter capacitor. In this situation, DSTATCOM should operate in CCM [5]. However, due to grid faults, source voltage (stiff or non stiff) can change at any time and then VCM operation is required. DSTATCOM regulates the load voltage by indirectly regulating the voltage across the feeder impedance. When a load is connected to nearly a stiff source, feeder impedance will be negligible [6]–[8]. Under these circumstances, DSTATCOM cannot provide sufficient voltage regulation at the load terminal [9].

This paper proposes a new control algorithm based DSTATCOM topology for voltage regulation even under stiff source. It is achieved by connecting a suitable external inductor in series between the load and the source point. Point of common coupling (PCC) will be the point where external inductor and source are connected. DSTATCOM,

# International Journal of Advanced Research in Electrical, Electronics and Instrumentation Engineering

(An ISO 3297: 2007 Certified Organization)

Website: [www.ijareeie.com](http://www.ijareeie.com)

Vol. 6, Issue 5, May 2017

connected at the load terminal, provides voltage regulation by indirectly regulating the voltage across the external inductor [10]. Proposed control algorithm to obtain variable reference load voltage is formulated as a function of the desired source current [11]. This voltage indirectly controls the current drawn from the source for a permissible range of source voltage [12]. Therefore, the control algorithm makes source currents balanced, sinusoidal, and in phase with respective source voltages during normal operation [13]. During voltage disturbances, a constant voltage is maintained at the load terminal [14]. Hence, proposed topology and control algorithm make compensator multifunctional so that it provides fast voltage regulation at load terminal and additionally provides advantages of CCM while operating in VCM [15].

## II. DSTATCOM CONFIGURATION

A neutral-point-clamped voltage source inverter (VSI) topology is chosen as it provides independent control of each leg of the VSI [7]. A single-phase equivalent circuit of DSTATCOM in a distribution network is shown in Fig.1. The VSI represented by  $uV_{dc}$  is connected to the load terminal through an LC filter ( $L_f - C_{fc}$ ) the load terminal is connected to the PCC through an external series inductance  $L_{ext}$ .  $V_{dc}$  is the voltage maintained across each dc capacitor, and  $u$  is a control variable, which can be +1 or -1, depending upon switching state.  $i_{fi}$ ,  $i_{ft}$ , and  $i_{fc}$  are currents through VSI, DSTATCOM, and  $C_{fc}$ , respectively.  $v_s$  and  $v_t$  are source and load voltages, respectively. Loads have both linear and nonlinear elements with balanced or unbalanced features. Load and source currents are represented by  $i_l$  and  $i_s$ , respectively.

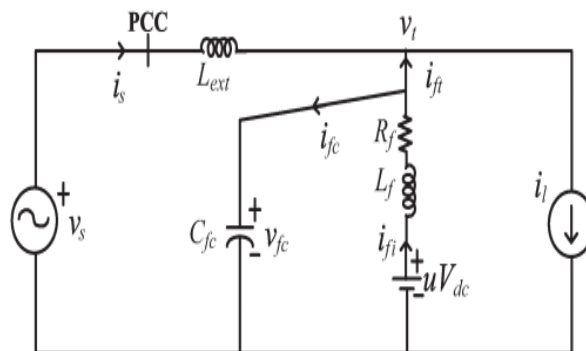

Fig.1. Single-phase equivalent circuit of DSTATCOM in a distribution network.

## III. SELECTION OF EXTERNAL INDUCTOR

Under normal operation, external impedance ( $Z_{ext}$ ) does not have much importance, whereas it plays a critical role during voltage disturbances. The value of external impedance is decided by the rating of the DSTATCOM and amount of sag to be mitigated. At any time, the source current in any phase by assuming balanced source voltage is given as

$$\bar{I}_s = \frac{V_s \angle 0 - V_t \angle -\delta}{R_{ext} + jX_{ext}} \quad (1)$$

Where  $V_s$ ,  $V_t$ ,  $R_{ext}$ ,  $X_{ext}$ , and  $\delta$  are the RMS source voltage, RMS load voltage, external resistance, external reactance, and load angle, respectively. For most practical case,  $X_{ext} \gg R_{ext}$ . As a worst case design, the reactive source current  $Im[\bar{I}_s]$ , which is supplied by the compensator, will be maximum when  $\delta$  is minimum. For this, the source will supply only losses in the VSI. Therefore,  $\delta$  will be very small. Hence,  $Im[\bar{I}_s]$  is given as



## International Journal of Advanced Research in Electrical, Electronics and Instrumentation Engineering

(An ISO 3297: 2007 Certified Organization)

Website: [www.ijareeie.com](http://www.ijareeie.com)

Vol. 6, Issue 5, May 2017

$$Im[\bar{I}_s] = \frac{V_t - V_s}{X_{ext}} \quad (2)$$

During voltage disturbances, the aim is to protect the sensitive loads, with focus on improving the DSTATCOM capability to mitigate deep sag. Therefore, keeping it into account, the load voltage during voltage sag is taken as 0.9 p.u. (per unit), which is sufficient to protect the load. Assuming that the reactive current that a compensator can inject is 20 A and the load needs to be protected from sag of 40%, then the value of external reactance is found to be

$$X_{ext} = \frac{0.9 - 0.6}{20} \times 230 = 3.45 \Omega. \quad (3)$$

An external reactance of 3.45  $\Omega$  that corresponds to an inductance of 11 mH for a 50-Hz supply is used.

### IV. PROPOSED CONTROL ALGORITHM

The proposed control algorithm aims to provide fast voltage regulation at the load terminal during voltage disturbances, while retaining the advantages of CCM during normal operation. First, the currents that must be drawn from the source to get advantages of CCM are computed. Using these currents, the magnitude of voltages that need to be maintained at the load terminal is computed. If this voltage magnitude lies within a permissible range, then the same voltage is used as reference voltage to provide advantages of CCM. If voltage lies outside the permissible range, it is a sign of voltage disturbance, and a fixed voltage magnitude is selected as reference voltage. A two loop controller, whose output is load angle  $\delta$ , is used to extract load power and VSI losses from the source. Finally, a discrete model is derived to obtain switching pulses. All these steps are presented in detail.

#### A. Computation of Reference Voltage Magnitude ( $V_t^*$ )

During normal operation, load voltage must be regulated in such a way that the following advantages provided by CCM operation are achieved.

- Source currents are balanced and sinusoidal.
- Unity power factor (UPF) at PCC.
- Source supplies load average power and VSI losses.

To achieve all aforementioned objectives, the instantaneous symmetrical component theory [15] is used to get reference source currents. DSTATCOM makes the load voltages balanced and sinusoidal, but still may contain some switching harmonics, which will give unacceptable reference source currents when directly used. Therefore, positive sequence components of load voltages ( $V_{ta1}^+$ ,  $V_{tb1}^+$ , and  $V_{tc1}^+$ ) are extracted and used to compute reference source currents ( $i_{sa}^*$ ,  $i_{sb}^*$ , and  $i_{sc}^*$ ) as follows:

$$\begin{aligned} i_{sa}^* &= \frac{v_{ta1}^+}{\Delta_1^+} (P_{lavg} + P_{loss}) \\ i_{sb}^* &= \frac{v_{tb1}^+}{\Delta_1^+} (P_{lavg} + P_{loss}) \\ i_{sc}^* &= \frac{v_{tc1}^+}{\Delta_1^+} (P_{lavg} + P_{loss}) \end{aligned} \quad (4)$$

# International Journal of Advanced Research in Electrical, Electronics and Instrumentation Engineering

(An ISO 3297: 2007 Certified Organization)

Website: [www.ijareeie.com](http://www.ijareeie.com)

Vol. 6, Issue 5, May 2017

Where  $\Delta_1^+ = \sum_{j=a,b,c} (v_{ij1}^+)$ , and  $P_{avg}$  is the average load power that is calculated using a moving average filter (MAF). The total losses in the inverter, i.e.,  $P_{loss}$ , computed using a PI controller, helps in maintaining the averaged dc-link voltage ( $V_{dc1} + V_{dc2}$ ) at a predefined reference value ( $2V_{dcref}$ ) by drawing a set of balanced currents from the source and is given as follows:

$$P_{loss} = K_{pdc} e + K_{idc} \int e dt \quad (5)$$

Where  $K_{pdc}$ ,  $K_{idc}$ , and  $e = 2V_{dcref} - (V_{dc1} + V_{dc2})$  are the proportional gain, integral gain, and voltage error of the PI controller, respectively. Once the reference currents to be drawn from the source are computed using (1.4), reference voltages at the load terminal can be derived. Applying Kirchoff's voltage law in the circuit shown in Fig.1:

$$\bar{V}_s = \bar{I}_s Z_{ext} + \bar{V}_t \quad (6)$$

Source voltage and source current will be in phase for the UPF operation. In addition, source voltage is taken as reference. Therefore,

$$V_s = I_s (R_{ext} + jX_{ext}) + V_t \angle -\delta \quad (7)$$

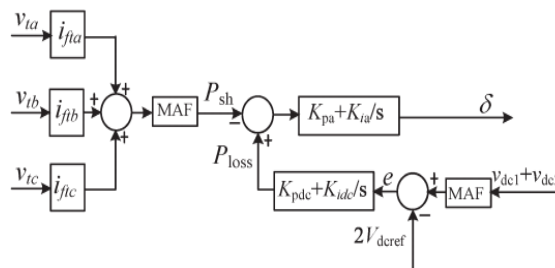

Fig.2. Controller to calculate  $\delta$  and  $P_{loss}$

From the previous equation, the load voltage can be computed as follows:

$$V_t = \sqrt{(V_s - I_s R_{ext})^2 + (I_s X_{ext})^2} \quad (8)$$

Based on standards, load voltage has a permissible range of variations between 0.9 and 1.1 p.u. [14]. Therefore, as long as  $V_t$ , obtained using (7), lies between 0.9 and 1.1 p.u., it is used as reference load voltage ( $V_t^*$ ), and the advantages of CCM operation are achieved. Here,  $V_t$  is indirectly controlled by the desired source current. During sag and swell, the load voltage magnitude will be between 0.9 and 1.1 p.u. and 1.1 and 1.8 p.u., respectively, for half cycle to 1 min [16]. Therefore, reference load voltage magnitude is set to 0.9 and 1.1 p.u. during sag and swell, respectively. The reason to keep load voltages at these values is to maximize the DSTATCOM disturbance withstanding ability while keeping load voltage at the safe limits for satisfactory operation. Therefore, the following conclusions can be drawn:

$$\begin{aligned} &\text{If } 0.9 \text{ p.u.} \leq V_t \leq 1.1 \text{ p.u. then } V_t^* = V_t \\ &\text{else If } V_t > 1.10 \text{ p.u. then } V_t^* = 1.1 \text{ p.u.} \\ &\text{else If } V_t < 0.9 \text{ p.u. then } V_t^* = 0.9 \text{ p.u.} \end{aligned} \quad (9)$$



## International Journal of Advanced Research in Electrical, Electronics and Instrumentation Engineering

(An ISO 3297: 2007 Certified Organization)

Website: [www.ijareeie.com](http://www.ijareeie.com)

Vol. 6, Issue 5, May 2017

### B. Computation of Load Angle ( $\Delta$ )

The block diagram of a controller to compute load angle  $\delta$  is shown in Fig. 2. It ensures that the load average power and losses in the VSI are supplied by the source [7]. Alternately,  $P_{loss}$  responsible for maintaining dc-link voltage must be equal to shunt-link power  $P_{sh}$ . Comparing  $P_{loss}$  and  $P_{sh}$ , an error is generated, which is passed through a PI controller to, compute  $\delta$  as follows:

$$\delta = K_{pa}(P_{loss} - P_{sh}) + K_{ia} \int (P_{loss} - P_{sh}) dt \quad (10)$$

Where  $K_{pa}$  and  $K_{ia}$  are the proportional and integral gains of the inner PI controller, respectively. The value of shunt-link power  $P_{sh}$  is computed using a MAF as follows:

$$P_{sh} = \frac{1}{T} \int_{t_1}^{t_1+T} (v_{ta}i_{fta} + v_{tb}i_{ftb} + v_{tc}i_{ftc}) dt. \quad (11)$$

A positive value of  $P_{sh}$  represents power flow from DSTATCOM to load terminal, whereas a negative value of  $P_{sh}$  represents power flow from load terminal to DSTATCOM. In steady state, VSI losses are compensated by taking power from the source. Hence,  $P_{sh}$  will be negative in steady state. Moreover, capacitor voltage decreases from its reference value in steady state. The deviation of capacitor voltage from reference voltage represents losses in the VSI. Hence,  $P_{loss}$  will be negative during steady state. Therefore, at all times,  $P_{sh}$  and  $P_{loss}$  should be equal. Hence, the difference of  $P_{sh}$  and  $P_{loss}$  should be minimized. The output of the inner PI controller, as shown in Fig. 2, is delta, which ensures that shunt-link power  $P_{sh}$  drawn from the source equals to losses in the capacitor  $P_{loss}$ .

### C. Generation of Instantaneous Reference Voltage

By knowing the zero crossing of phase-*a* source voltage, selecting a suitable reference load voltage magnitude from (1.9), and computing load angle  $\delta$  from (2.0), the three-phase reference voltages are given as follows:

$$\begin{aligned} v_{trefa} &= \sqrt{2}V_t^* \sin(\omega t - \delta) \\ v_{trefb} &= \sqrt{2}V_t^* \sin(\omega t - 2\pi/3 - \delta) \\ v_{trefc} &= \sqrt{2}V_t^* \sin(\omega t + 2\pi/3 - \delta) \end{aligned} \quad (12)$$

Where  $\omega$  is the system frequency.

### D. Generation of Switching Pulses

Each phase of the VSI can be controlled independently, and hence, a discrete model of single phase has been derived to generate switching pulses. The dynamics of filter inductor and capacitor can be presented by the following equations:

$$\begin{aligned} \frac{dv_{fc}}{dt} &= \frac{1}{C_{fc}} i_{fi} - \frac{1}{C_{fc}} i_{ft} \\ \frac{di_{fi}}{dt} &= -\frac{1}{L_f} v_{fc} - \frac{R_f}{L_f} i_{fi} + \frac{V_{dc}}{L_f} u \end{aligned} \quad (13)$$



## International Journal of Advanced Research in Electrical, Electronics and Instrumentation Engineering

(An ISO 3297: 2007 Certified Organization)

Website: [www.ijareeie.com](http://www.ijareeie.com)

Vol. 6, Issue 5, May 2017

A matrix representation of (12) is given as follows:

$$\dot{x} = Ax + Bz \quad (14)$$

Where

$$A = \begin{bmatrix} 0 & 1/C_{fc} \\ 1/L_f & -R_f/L_f \end{bmatrix}, \quad B = \begin{bmatrix} 0 & 1/C_{fc} \\ V_{dc}/L_f & 0 \end{bmatrix}$$

$$x = [v_{fc} \quad i_{fi}]^t, \quad z = [u \quad i_{ft}]^t. \quad (15)$$

Equation (14), given in continuous form, can be represented in a discrete-time form as follows:

$$x(k+1) = Gx(k) + Hz(k) \quad (16)$$

Where matrices  $G$  and  $H$  are given as

$$G = \begin{bmatrix} G_{11} & G_{12} \\ G_{21} & G_{22} \end{bmatrix}, \quad H = \begin{bmatrix} H_{11} & H_{12} \\ H_{21} & H_{22} \end{bmatrix}$$

From (16), capacitor voltage will be

$$v_{fc}(k+1) = G_{11}v_{fc}(k) + G_{12}i_{fi}(k) + H_{11}u(k) + H_{12}i_{ft}(k) \quad (17)$$

The reference voltage  $V_{tref}$  is maintained at the load terminal. A cost function  $J$  is chosen as

$$J = [v_{tref}(k+1) - v_{fc}(k+1)]^2 \quad (18)$$

Cost function is minimum when

$$v_{fc}(k+1) = v_{tref}(k+1) \quad (19)$$

Finally, the reference discrete voltage control law from (17) and (19) is given as

$$u^*(k) = \frac{v_{tref}(k+1) - G_{11}v_{fc}(k) - G_{12}i_{fi}(k) - H_{12}i_{ft}(k)}{H_{11}} \quad (20)$$

$u^*(k)$  is regulated around a hysteresis band  $h$  to generate switching pulses of VSI using hysteresis control.

### V. INDUCTION MOTOR

An asynchronous motor type of an induction motor is an AC electric motor in which the electric current in the rotor needed to produce torque is obtained by electromagnetic induction from the magnetic field of the stator winding. An induction motor can therefore be made without electrical connections to the rotor as are found in universal, DC and synchronous motors. An asynchronous motor's rotor can be either wound type or squirrel-cage type.

Three-phase squirrel-cage asynchronous motors are widely used in industrial drives because they are rugged, reliable and economical. Single-phase induction motors are used extensively for smaller loads, such as household appliances like fans. Although traditionally used in fixed-speed service, induction motors are increasingly being used with variable-frequency drives (VFDs) in variable-speed service. VFDs offer especially important energy savings opportunities for existing and prospective induction motors in variable-torque centrifugal fan, pump and compressor load applications. Squirrel cage induction motors are very widely used in both fixed-speed and variable-frequency drive (VFD) applications. Variable voltage and variable frequency drives are also used in variable-speed service.

In both induction and synchronous motors, the AC power supplied to the motor's stator creates a magnetic field that rotates in time with the AC oscillations. Whereas a synchronous motor's rotor turns at the same rate as the stator field, an induction motor's rotor rotates at a slower speed than the stator field. The induction motor stator's magnetic field is therefore changing or rotating relative to the rotor. This induces an opposing current in the induction



# International Journal of Advanced Research in Electrical, Electronics and Instrumentation Engineering

(An ISO 3297: 2007 Certified Organization)

Website: [www.ijareeie.com](http://www.ijareeie.com)

Vol. 6, Issue 5, May 2017

motor's rotor, in effect the motor's secondary winding, when the latter is short-circuited or closed through external impedance. The rotating magnetic flux induces currents in the windings of the rotor; in a manner similar to currents induced in a transformer's secondary winding(s). The currents in the rotor windings in turn create magnetic fields in the rotor that react against the stator field. Due to Lenz's Law, the direction of the magnetic field created will be such as to oppose the change in current through the rotor windings. The cause of induced current in the rotor windings is the rotating stator magnetic field, so to oppose the change in rotor-winding currents the rotor will start to rotate in the direction of the rotating stator magnetic field. The rotor accelerates until the magnitude of induced rotor current and torque balances the applied load. Since rotation at synchronous speed would result in no induced rotor current, an induction motor always operates slower than synchronous speed. The difference, or "slip," between actual and synchronous speed varies from about 0.5 to 5.0% for standard Design B torque curve induction motors. The induction machine's essential character is that it is created solely by induction instead of being separately excited as in synchronous or DC machines or being self-magnetized as in permanent magnet motors.

For rotor currents to be induced the speed of the physical rotor must be lower than that of the stator's rotating magnetic field ( $n_s$ ); otherwise the magnetic field would not be moving relative to the rotor conductors and no currents would be induced. As the speed of the rotor drops below synchronous speed, the rotation rate of the magnetic field in the rotor increases, inducing more current in the windings and creating more torque. The ratio between the rotation rate of the magnetic field induced in the rotor and the rotation rate of the stator's rotating field is called slip. Under load, the speed drops and the slip increases enough to create sufficient torque to turn the load. For this reason, induction motors are sometimes referred to as asynchronous motors.[25] An induction motor can be used as an induction generator, or it can be unrolled to form a linear induction motor which can directly generate linear motion.

### Synchronous Speed:

The rotational speed of the rotating magnetic field is called as synchronous speed.

$$N_s = \frac{120 \times f}{P} \quad (\text{RPM}) \quad (21)$$

Where,  $f$  = frequency of the supply  
 $P$  = number of poles

**Slip:** Rotor tries to catch up the synchronous speed of the stator field, and hence it rotates. But in practice, rotor never succeeds in catching up. If rotor catches up the stator speed, there won't be any relative speed between the stator flux and the rotor, hence no induced rotor current and no torque production to maintain the rotation. However, this won't stop the motor, the rotor will slow down due to lost of torque, the torque will again be exerted due to relative speed. That is why the rotor rotates at speed which is always less the synchronous speed.

The difference between the synchronous speed ( $N_s$ ) and actual speed ( $N$ ) of the rotor is called as slip.

$$\% \text{ slip } s = \frac{N_s - N}{N_s} \times 100 \quad (22)$$

## VI. MATLAB/SIMULATION RESULTS

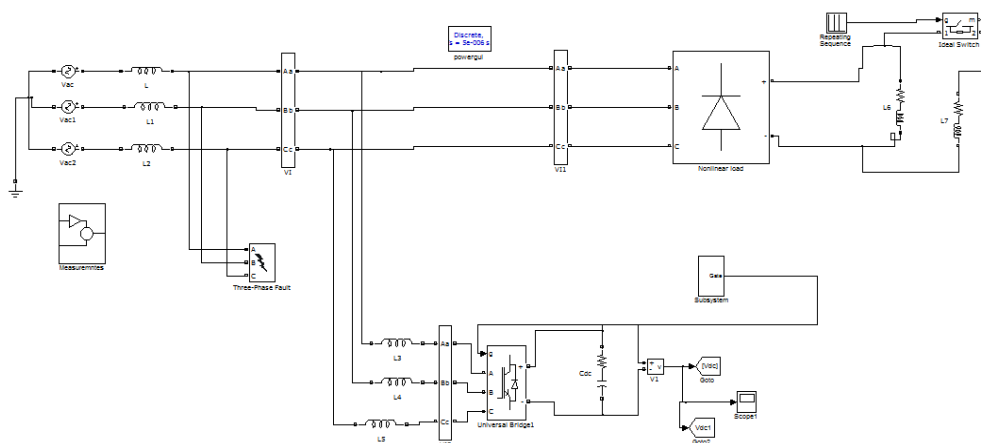

Fig.3 Simulink model of DSTATCOM



# International Journal of Advanced Research in Electrical, Electronics and Instrumentation Engineering

(An ISO 3297: 2007 Certified Organization)

Website: [www.ijareeie.com](http://www.ijareeie.com)

Vol. 6, Issue 5, May 2017

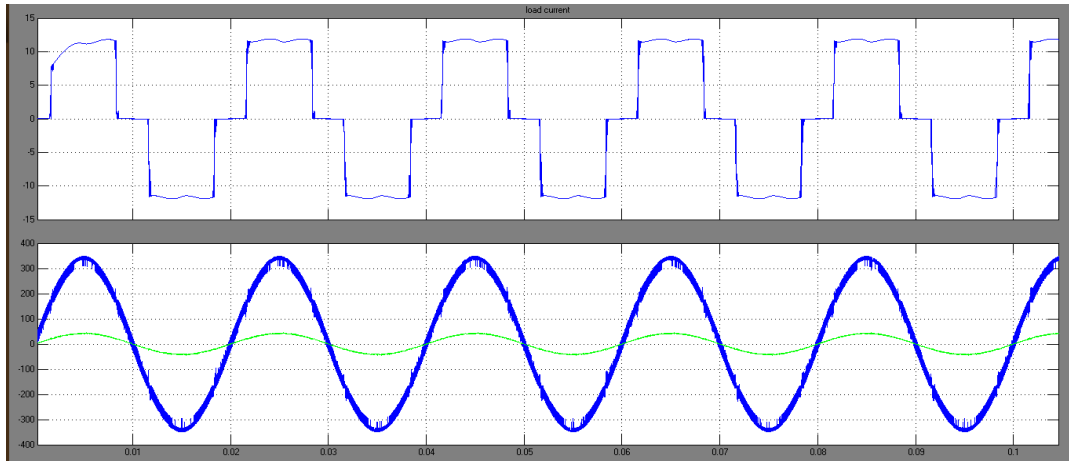

Fig.4 (a) Load current (b) Source voltage and source current

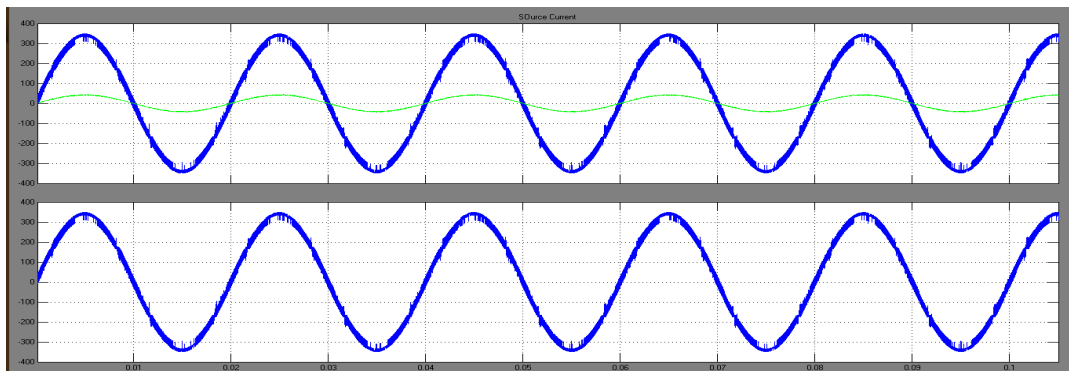

Fig.5 (a) Source voltage and source current (b) Load voltage



Fig.6 (a) Voltage across dc bus. (b) Load angle  $\delta$



# International Journal of Advanced Research in Electrical, Electronics and Instrumentation Engineering

(An ISO 3297: 2007 Certified Organization)

Website: [www.ijareeie.com](http://www.ijareeie.com)

Vol. 6, Issue 5, May 2017

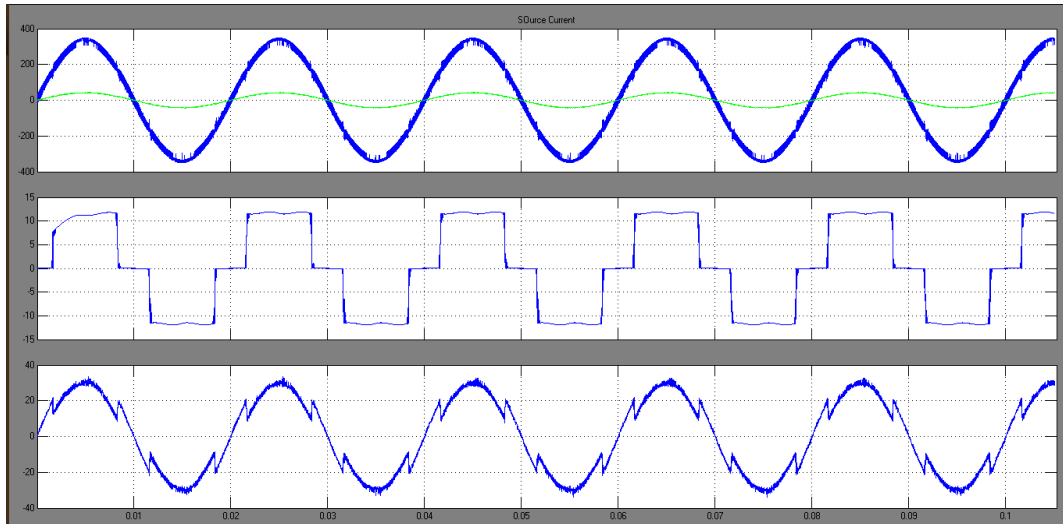

Fig.7 (a) Source voltage and source current (b) load current (c) Injected current

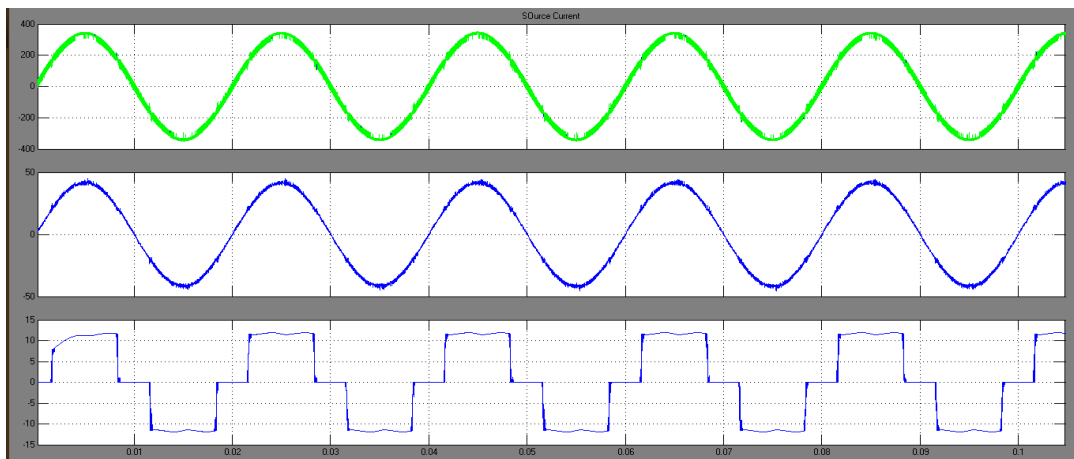

Fig.8 (a) Source voltage (b) Source current (c) Load current

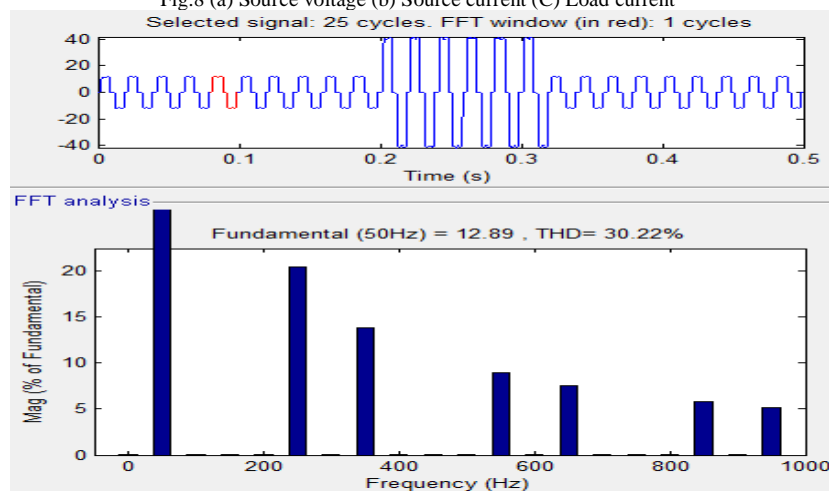

Fig.9(a) Source current THD with out DSTATCOM

# International Journal of Advanced Research in Electrical, Electronics and Instrumentation Engineering

(An ISO 3297: 2007 Certified Organization)

Website: [www.ijareeie.com](http://www.ijareeie.com)

Vol. 6, Issue 5, May 2017

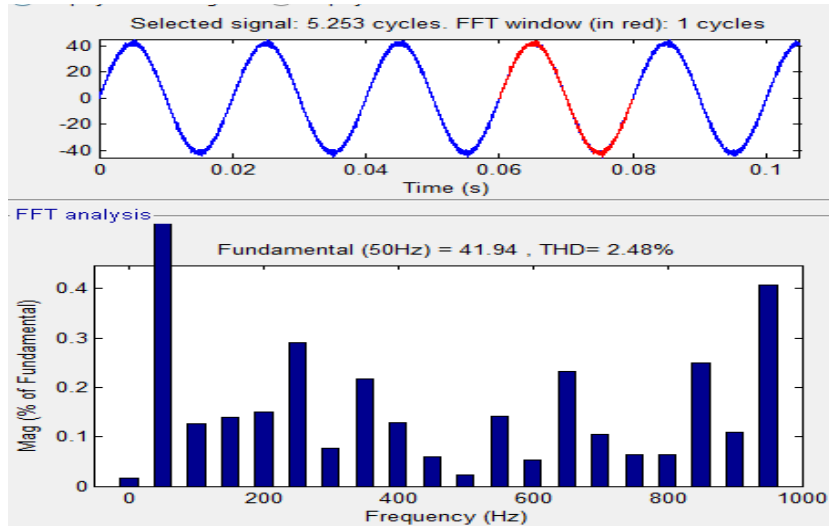

Fig.9(b) Source current THD with DSTATCOM

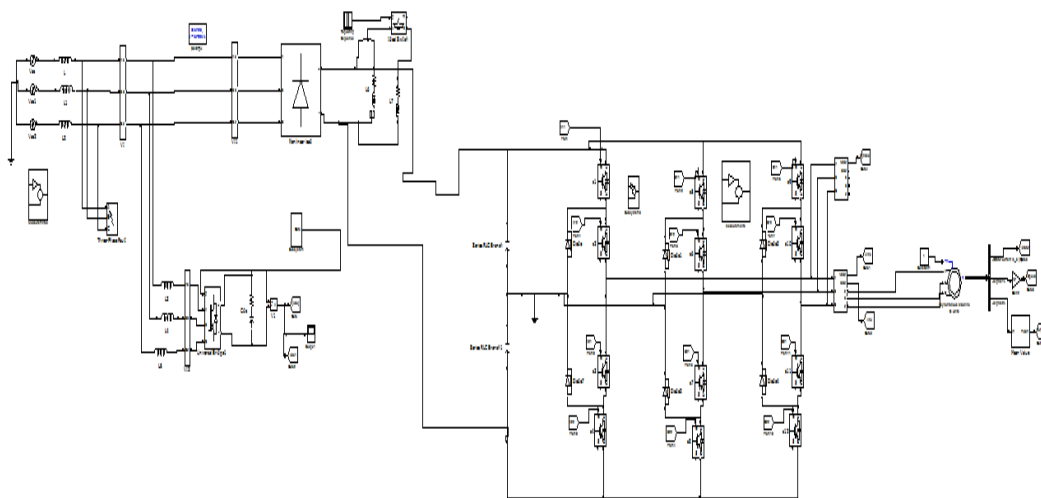

Fig.10 Simulink model of DSTATCOM with Induction Motor Drive

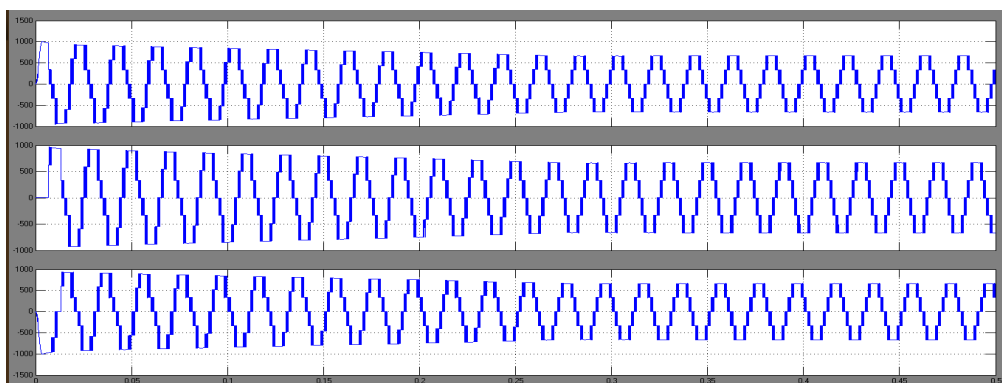

Fig.11 Line voltages



# International Journal of Advanced Research in Electrical, Electronics and Instrumentation Engineering

(An ISO 3297: 2007 Certified Organization)

Website: [www.ijareeie.com](http://www.ijareeie.com)

Vol. 6, Issue 5, May 2017

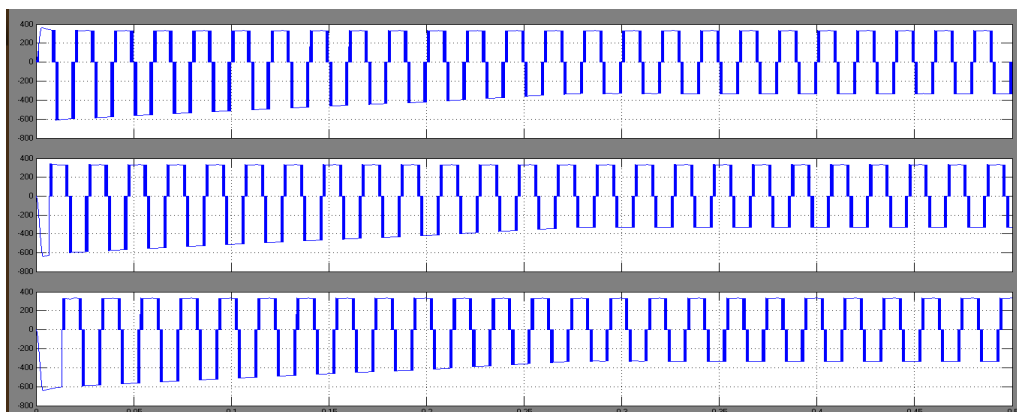

Fig.12 Phase voltages

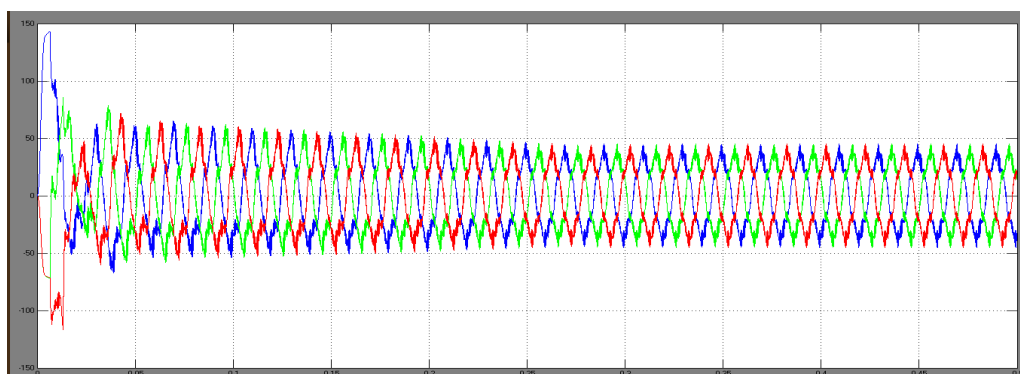

Fig.13 Line currents

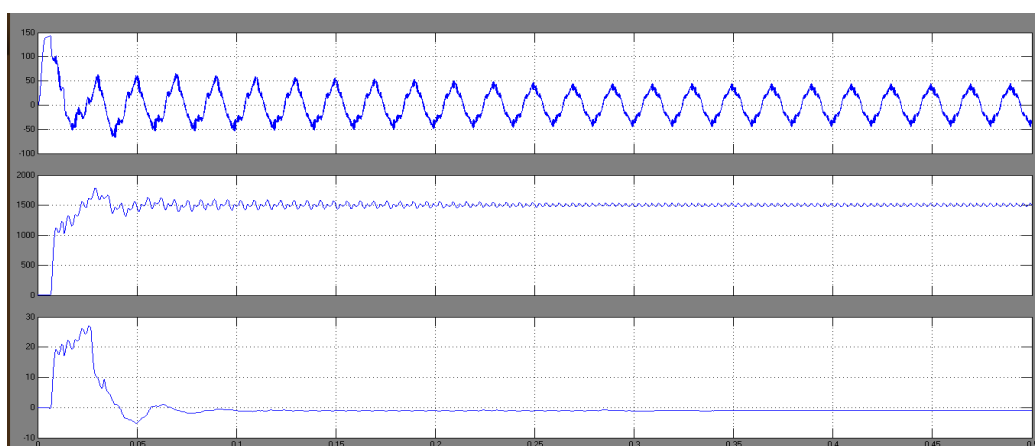

Fig.14 Stator current, Speed and Torque

## VII. CONCLUSION

In this paper was presented a control scheme for DSTATCOM current controlled that was used for voltage magnitude regulation at point of common coupling (PCC) through reactive injection, also it mitigates voltage harmonics through PCC voltage detection. The proposed which has superior features over conventional topologies in terms of the required power switches and isolated dc supplies, control requirements, cost, and reliability with a new control algorithm based multifunctional DSTATCOM is proposed to protect the load from voltage disturbances under



# International Journal of Advanced Research in Electrical, Electronics and Instrumentation Engineering

(An ISO 3297: 2007 Certified Organization)

Website: [www.ijareeie.com](http://www.ijareeie.com)

Vol. 6, Issue 5, May 2017

stiff source. It has been achieved by placing an external series inductance of suitable value between the source and the load. Moreover protects the Induction machine drive through DSTATCOM under power quality concerns with near to optimal features with efficient operation.

## REFERENCES

- [1] A. Bhattacharya and C. Chakraborty, "A shunt active power filter with enhanced Performance using ANN-based predictive and adaptive controllers," *IEEE Trans. Ind. Electron.*, vol. 58, no. 2, pp. 421–428, Feb. 2011.
- [2] S. Rahmani, A. Hamadi, and K. Al-Haddad, "A Lyapunov-function-based control for a three-phase shunt hybrid active filter," *IEEE Trans. Ind. Electron.*, vol. 59, no. 3, pp. 1418–1429, Mar. 2012.
- [3] M. K. Mishra and K. Karthikeyan, "An investigation on design and switching dynamics of a voltage source inverter to compensate unbalanced and nonlinear loads," *IEEE Trans. Ind. Electron.*, vol. 56, no. 8, pp. 2802–2810, Aug. 2009.
- [4] J. Liu, P. Zanchetta, M. Degano, and E. Lavopa, "Control design and implementation for high performance shunt active filters in aircraft powergrids," *IEEE Trans. Ind. Electron.*, vol. 59, no. 9, pp. 3604–3613, Sep. 2012.
- [5] A. Bhattacharya, C. Chakraborty, and S. Bhattacharya, "Parallel connected shunt hybrid active power filters operating at different switching frequencies for improved performance," *IEEE Trans. Ind. Electron.*, vol. 59, no. 11, pp. 4007–4019, Nov. 2012.
- [6] Q.-N. Trinh and H.-H. Lee, "An advanced current control strategy for three-phase shunt active power filters," *IEEE Trans. Ind. Electron.*, vol. 60, no. 12, pp. 5400–5410, Dec. 2013.
- [7] M. K. Mishra, A. Ghosh, and A. Joshi, "Operation of a DSTATCOM in voltage control mode," *IEEE Trans. Power Del.*, vol. 18, no. 1, pp. 258–264, Jan. 2003.
- [8] H. Fujita and H. Akagi, "Voltage-regulation performance of a shunt active filter intended for installation on a power distribution system," *IEEE Trans. Power Electron.*, vol. 22, no. 3, pp. 1046–1053, May 2007.
- [9] R. Gupta, A. Ghosh, and A. Joshi, "Performance comparison of VSC based shunt and series compensators used for load voltage control in distribution systems," *IEEE Trans. Power Del.*, vol. 26, no. 1, pp. 268–278, Jan. 2011.
- [10] F. Gao and M. Iravani, "A control strategy for a distributed generation unit in grid-connected and autonomous modes of operation," *IEEE Trans. Power Del.*, vol. 23, no. 2, pp. 850–859, Apr. 2008.
- [11] Y.-R. Mohamed, "Mitigation of dynamic, unbalanced, and harmonic voltage disturbances using grid-connected inverters with LCL filter," *IEEE Trans. Ind. Electron.*, vol. 58, no. 9, pp. 3914–3924, Sep. 2011.
- [12] R. Gupta, A. Ghosh, and A. Joshi, "Multiband hysteresis modulation and switching characterization for sliding-mode-controlled cascaded multilevel inverter," *IEEE Trans. Ind. Electron.*, vol. 57, no. 7, pp. 2344–2353, Jul. 2010.
- [13] A. Camacho, M. Castilla, J. Miret, J. Vasquez, and E. Alarcon-Gallo, "Flexible voltage support control for three-phase distributed generation inverters under grid fault," *IEEE Trans. Ind. Electron.*, vol. 60, no. 4, pp. 1429–1441, Apr. 2013.
- [14] M. Moradlou and H. Karshenas, "Design strategy for optimum rating selection of interline DVR," *IEEE Trans. Power Del.*, vol. 26, no. 1, pp. 242–249, Jan. 2011.
- [15] S. Srikanthan and M. K. Mishra, "DC capacitor voltage equalization in neutral clamped inverters for DSTATCOM application," *IEEE Trans. Ind. Electron.*, vol. 57, no. 8, pp. 2768–2775, Aug. 2010.

## BIOGRAPHY



**Baratam Murali** was born in 1991 month of August 25<sup>th</sup>. He received his B.Tech degree in Electrical and electronics Engineering from Sri Sai Madhavi Inst of Sci & Tech in 2012. At present pursuing M.Tech specialization in Power electronics in Sri Sivani College of Engineering, Chilakapalem in., Srikakulam district, Andhra Pradesh, India.



**Budi Srinivasarao** Completed his graduation in Electrical and Electronics Engineering from Gokul Inst Of Sci&Tech, Bobilli in the Year 2010 and received his M.Tech from Dadi Inst Of Sci & Tech, Anakapalli in 2013. He is presently working as Assistant Professor in Department of Electrical & Electronics Engineering in Sri Sivani College of Engineering, Chilakapalem in., Srikakulam district, Andhra Pradesh, India. His areas of Interest are Power Electronics & Industrial Drives.