



ISSN (Print) : 2320 – 3765  
ISSN (Online): 2278 – 8875

## International Journal of Advanced Research in Electrical, Electronics and Instrumentation Engineering

(An ISO 3297: 2007 Certified Organization)

Vol. 5, Special Issue 8, November 2016

# Integration of Renewable Energy Sources Wind and Solar Power Grid Connected Using MMPT & Flywheel / Simulink

Chudaykiran<sup>1</sup>, Mahesh<sup>2</sup>

M. Tech (EPS), Padmasri Dr. B. V. RAJU Institute of Technology, Narsapure Medak, Telangana, India<sup>1</sup>

Assistant Professor, Department of EEE, Padmasri Dr. B. V. RAJU Institute of Technology Narsapure, Medak Dist,  
Telangana, India<sup>2</sup>

**ABSTRACT:** The integration of wind, solar power and flying capacitor with DC micro grids. An aggregated model of renewable wind and solar power generation proposed to support the increases renewable energy sources. And equilibrium of the micro grid's real-time supply and demand, implemented high-rise host building of an urban area

**KEYWORDS:** Photovoltaic system, Wind system, Maximum Power Point Tracking, Rectifier, Inverter.

### I. INTRODUCTION

Saving Earth's energy has become an important issue in this century because energy famine will occur after a few decades. The interest in solar power has been rapidly growing due to its advantages that include

- i. Direct electric power form;
- ii. Little maintenance;
- iii. No noise;
- iv. No pollution

Since solar power uses the photovoltaic (PV) effect to transform solar energy into electrical energy, the PV panel is a nonlinear power source. The output power of a PV panel array depends on the PV voltage

and unpredictable weather conditions. In order to optimize the ratio between output power and installation cost, dc/dc converters are used to draw maximum power from the PV panel array. Renewable energy, such as solar energy, is desirable for power generation due to their unlimited existence and environmental friendly nature. The many different techniques for maximum power point tracking of PV arrays are discussed. Maximum power point tracking (MPPT) is used in PV systems to maximize the photovoltaic array output power, irrespective of the temperature and irradiation conditions and of the load electrical characteristics. This paper is a continuation in building a hybrid wind-PV generation system. The combination of wind and solar energy resources on a rooftop was also investigated in [1]. The main enhancement of the study is a solution regarding the overloading of the system which has happened in many occasions. The reduced power mode (RPM) of operation as proposed in this study can be used to suppress the oscillation due to the fast response of the PV generator. It was verified that the combination of wind and solar energy leads to reduced local storage requirements [2]. Furthermore, excessive solar radiation at a low temperature can also overload the power electronics in the system. Therefore, among all renewable energy sources, solar power systems attract more attention because they provide excellent opportunity to generate electricity while greenhouse emissions are reduced. Where a super capacitor or flywheel provides cache control to compensate for fast power fluctuations and to smoothen the transients encountered by a battery with higher energy capacity [3], [4]. Microgrids or hybrid energy systems have been shown to be an effective structure for local interconnection of distributed renewable generation,

# International Journal of Advanced Research in Electrical, Electronics and Instrumentation Engineering

(An ISO 3297: 2007 Certified Organization)

Vol. 5, Special Issue 8, November 2016

loads, and storage [5]–[10]. It is also gratifying to lose reliance on conventional electricity generated by burning coal and natural gas. The PV generator should normally operate in the MPPT mode. Methods for MPPT include “open circuit voltage,” “short-circuit current,” “pilot cell,” and “hill climbing”. Because of the low cost and simplicity in using a dc/dc boost converter, “hill climbing” is perhaps the most widely used and is often implemented in a “perturb–observe” algorithm. However, the searching process for the maximum power point can easily fail to converge if the radiation changes rapidly and frequently. Incremental conductance (IC) is another interesting method which has previously been verified. To improve convergence, a variable-step incremental conductance method was proposed. A similar algorithm is proposed in this study with direct duty ratio adjustment

## II. WIND ENERGY

Wind can be economically used for the generation of electrical energy. Heating and cooling of the atmosphere with generates convection current. Heating is caused by the absorption of solar energy on the earth surface and in the atmosphere. The rotation of the earth with respect to atmosphere and its motion around the sun. There are two primary physical principles by which energy can be extracted from the wind; these are through the creation of either lift or drag force (or through a combination of the two). The difference between drag and lift is illustrated by the difference between using a spinnaker sail, which fills like a parachute and pulls a sailing boat with the wind, and a Bermuda rig, the familiar triangular sail which deflects with wind and allows a sailing boat to travel across the wind or slightly into the wind. Drag forces provide the most obvious means of propulsion, these being the forces felt by a person (or object) exposed to the wind. Lift forces are the most efficient means of propulsion but being more



Wind Energy system

subtle than drag forces are not so well understood. The difference between drag and lift is illustrated by the difference between using a spinnaker sail, which fills like a parachute and pulls a sailing boat with the wind.

## III. OUTLINE OF DC MICROGRID

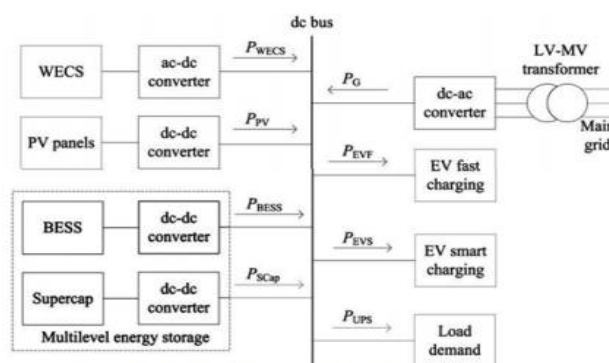

Fig:1 Outline diagram of the dc micro grid

# International Journal of Advanced Research in Electrical, Electronics and Instrumentation Engineering

(An ISO 3297: 2007 Certified Organization)

Vol. 5, Special Issue 8, November 2016

The difference between drag and lift is illustrated by the difference between using a spinnaker sail, which fills like a parachute and pulls a sailing boat with the wind, and a Bermuda rig, the familiar triangular sail which deflects with wind and allows a sailing boat to travel across the wind or slightly into the wind. Drag forces provide the most obvious means of propulsion, these being the forces felt by a person (or object) exposed to the wind. Lift forces are the most efficient means of propulsion but being more subtle than drag forces are not so well understood

## IV. PV SYSTEM

There is an enormous supply of articles on the subject of photovoltaic power. Most articles are narrow in scope, perhaps announcing a recent breakthrough or discussing a particular project or application. The internet provides a great deal of information as well, with web sites sponsored by government agencies, industry groups, and manufacturers. We did have some difficulty finding an overview of the subject. Most books on photovoltaic are at least five years old and cover the technical aspect of photovoltaic without providing an assessment of the practicality of using photovoltaic's for power generation. The high cost of generating electrical power using photovoltaic cells compared to conventional coal-, gas-, and nuclear-powered generators has kept PV power generation from being in widespread use. Less than 1% of electricity is generated by photovoltaic. However, there are a few applications in which PV power is economical. These applications include satellites, developing countries that lack a power distribution infrastructure, and remote or rugged areas where running distribution lines are not practical. As the cost of photovoltaic systems drops, more applications become economically feasible. The non-polluting aspect of PV power can make it an attractive choice even when conventional generating systems are more economical. The manufacture of photovoltaic systems has increased steadily for the last 25 years. It is inevitable those engineers will be called upon to develop photovoltaic technology or will be involved in projects using this technology. Many existing reports on photovoltaic cover only one facet of the technology and sometimes writers inflate their reports on behalf of the company involved. There is a need for an up-to-date, objective understanding of photovoltaic power generation. With this goal in mind we have created this report. Recent research has considered the optimization of the operation on one hand [11]–[13] and the usage of dc to link the resources on the other [14]–[16].

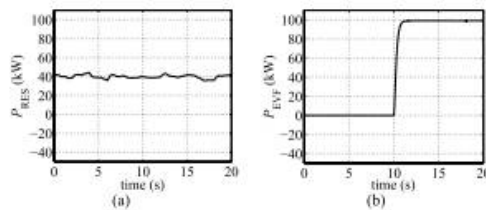

Case study: Assumptions of the simulation. (a) Renewable power generation. (b) Fast charging load connected to the dc bus.

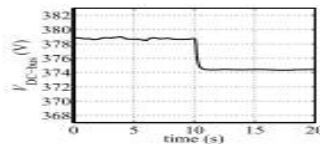

Case B: dc bus voltage profile.

# International Journal of Advanced Research in Electrical, Electronics and Instrumentation Engineering

(An ISO 3297: 2007 Certified Organization)

Vol. 5, Special Issue 8, November 2016

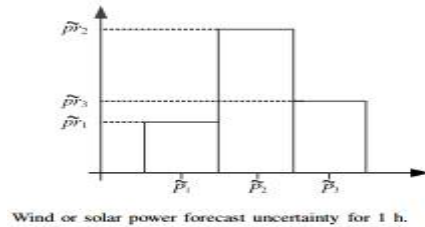

## V. SUPER CAPACITOR

high-capacity electrochemical capacitor with capacitance values much higher than other capacitors (but lower voltage limits) that bridge the gap between electrolytic capacitors and rechargeable batteries. They typically store 10 to 100 times more energy per unit volume or mass than electrolytic capacitors, can accept and deliver charge much faster than batteries, and tolerate many more charge and discharge cycles than rechargeable batteries. They are however 10 times larger than conventional batteries for a given charge. Supercapacitors are used in applications requiring many rapid charge/discharge cycles rather than long term compact energy storage: within cars, buses, trains, cranes and elevators, where they are used for regenerative braking, short-term energy storage or burst-mode power delivery. Smaller units are used as memory backup for static random-access memory (SRAM). Supercapacitors do not use the conventional solid dielectric of ordinary capacitors.

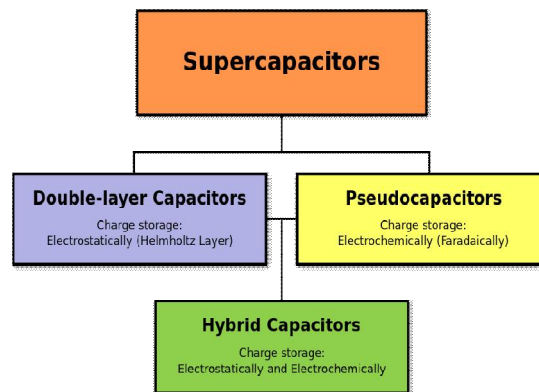

They use electrostatic double-layer capacitance or electrochemical pseudocapacitance or a combination of both instead. Electrostatic double-layer capacitors use carbon electrodes or derivatives with much higher electrostatic double-layer capacitance than electrochemical pseudocapacitance, achieving separation of charge in a Helmholtz double layer at the interface between the surface of a conductive electrode and an electrolyte. The separation of charge is of the order of a few ångströms (0.3–0.8 nm), much smaller than in a conventional capacitor. Electrochemical pseudocapacitors use metal oxide or conducting polymer electrodes with a high amount of electrochemical pseudocapacitance. Pseudocapacitance is achieved by Faradaic electron charge-transfer with redox reactions, intercalation or electrosorption. Hybrid capacitors, such as the lithium-ion capacitor, use electrodes with differing characteristics: one exhibiting mostly electrostatic capacitance and the other mostly electrochemical capacitance.

## II. BATTERY ENERGY STORAGE FOR

### GRID STABILIZATION

Today's and future power grids are characterised by a high share of renewable energy sources. This leads to a massive fluctuating power injection, which needs to be balanced by battery energy storage. AEG PS has developed a new

# International Journal of Advanced Research in Electrical, Electronics and Instrumentation Engineering

(An ISO 3297: 2007 Certified Organization)

Vol. 5, Special Issue 8, November 2016

innovative Battery Energy Storage System for low voltage (LV) and medium voltage (MV), that provides grid stabilization and increased power quality: Four-Quadrant Operation (Active and Reactive Power Control), Peak Shaving and Load Balancing, day to night shifting of renewable PV Energy, reliable PV Power Supply by rolling clouds and provide control power to participate in this market. The further advantage of the AEG PS' new battery energy storage is the ability to control harmonic emissions of power electronic equipment connected to the same busbar, by the use of active damping or active filtering functionality.



## SIMULATION RESULTS

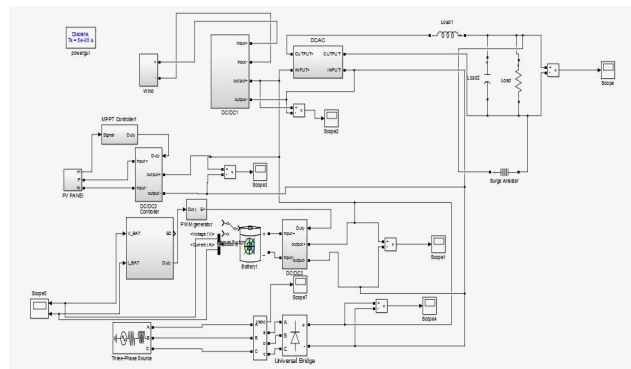

## GRID CONNECTED OUT PUTS



Final out put

# International Journal of Advanced Research in Electrical, Electronics and Instrumentation Engineering

(An ISO 3297: 2007 Certified Organization)

Vol. 5, Special Issue 8, November 2016

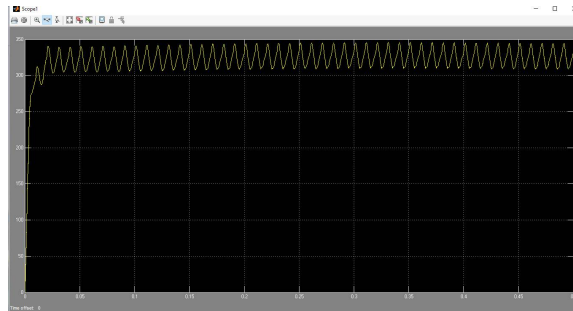

scope 1 Battery output

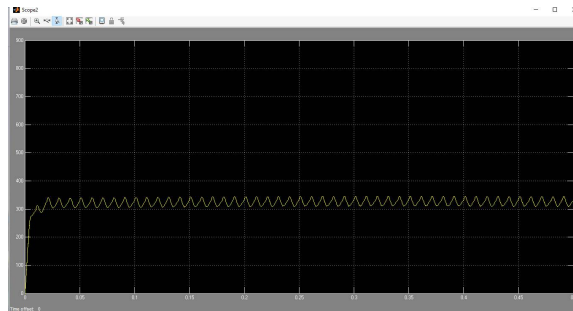

Scope 2 Wind out put

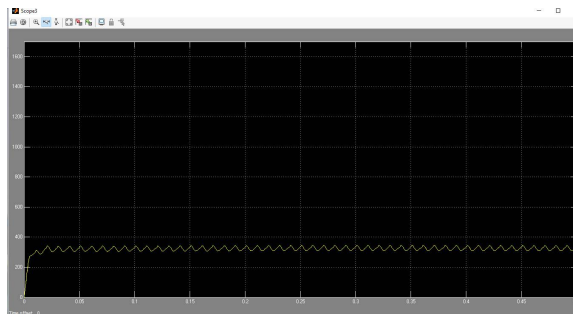

Scope 3 PV CELL out put

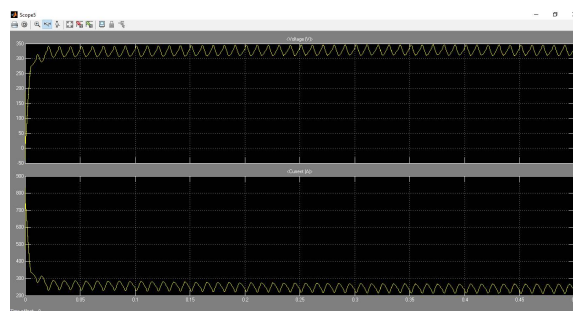

Scope 4 3- Phase Grid

# International Journal of Advanced Research in Electrical, Electronics and Instrumentation Engineering

(An ISO 3297: 2007 Certified Organization)

Vol. 5, Special Issue 8, November 2016

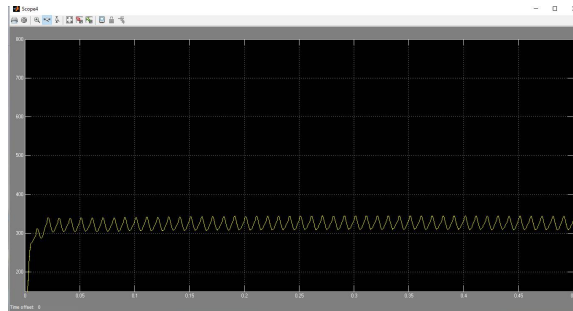

Scope5Battery Characteristics

### III. OPERATIONAL OPTIMIZATION OF MICROGRID FOR RENEWABLE ENERGY INTEGRATION

In the proposed system, the wind and solar energy will be used as distributed generation sources for the Microgrid. The power generated from this should smooth using the smoothing control unit which contains Super capacitor for reducing the power fluctuations.

This smoothed power after converting into required level should be given to the Battery energy storage system to meet the supply and demand of the loads. From the battery energy storage system, the power will be making available to the DC and AC consumers for use. In this way, it will increase the efficiency of the system with reduction in the various losses.

### IV. OPERATIONAL OVERVIEW

In the proposed system, the wind and solar energy will be used as distributed generation sources for the Microgrid. The power generated from this should smooth using the smoothing control unit which contains Supercapacitor for reducing the power fluctuations.

This smoothed power after converting into required level should be given to the Battery energy storage system to meet the supply and demand of the loads. From the battery energy storage system, the power will be making available to the DC and AC consumers for use. In this way, it will increase the efficiency of the system with reduction in the various losses

### V. EXPECTED OUTCOME

Expected output of the proposed system must have been more smoothed output with Low power fluctuation. Also, the efficiency will be increased and losses will be decreased. This will be obtained with smoothing control unit using MPPT& Fly wheel In future, the improvement in efficient wind and solar power integration along with the lengthening the battery life of battery energy storage system using flywheel is expected.

### VI. CONCLUSIONS

The MPPT controller incorporating an RPM algorithm was developed in consistence with the previous design of the perturbation parameters. The proposed control algorithms based on a VSIC method. This is easy to implement in simple microcontrollers and is fast as compared to normal fixed-step IC and perturb and observe algorithms. The RPM was used to limit the output power of the PV generator if the generation exceeds the system rating due to reduced ambient temperature and high solar radiation. This mode can also be used when there is excessive energy to be stored in a stand-alone system. The proposed algorithm has been validated by simulation and laboratory experiment. It can be seen that the proposed algorithm can prevent oscillation and is able to quickly track the optimal operating point in severe transient conditions with changes of solar radiation and temperature



ISSN (Print) : 2320 – 3765  
ISSN (Online): 2278 – 8875

# International Journal of Advanced Research in Electrical, Electronics and Instrumentation Engineering

(An ISO 3297: 2007 Certified Organization)

Vol. 5, Special Issue 8, November 2016

## REFERENCES

- [1] F. Giraud and Z. M. Salameh, "Steady-state performance of a grid-connected rooftop hybrid wind-photovoltaic power system with battery storage," *IEEE Trans. Energy Convers.*, vol. 16, no. 1, pp. 1–7, Mar. 2001.
- [2] B. S. Borowy and Z. M. Salameh, "Methodology for optimally sizing the combination of a battery bank and PV array in a wind/PV hybrid system," *IEEE Trans. Energy Convers.*, vol. 11, no. 2, pp. 367–375, Mar. 1996.
- [3] M. Cheng, S. Kato, H. Sumitani, and R. Shimada, "Flywheel-based AC cache power for stand-alone power systems," *IEEJ Trans. Electr. Electron. Eng.*, vol. 8, no. 3, pp. 290–296, May 2013.
- [4] H. Louie and K. Strunz, "Superconducting magnetic energy storage (SMES) for energy cache control in modular distributed hydrogen-electric energy systems," *IEEE Trans. Appl. Supercond.*, vol. 17, no. 2, pp. 2361–2364, Jun. 2007.
- [5] A. L. Dimeas and N. D. Hatziargyriou, "Operation of a multiagent system for microgrid control," *IEEE Trans. Power Syst.*, vol. 20, no. 3, pp. 1447–1455, Aug. 2005.
- [6] F. Katiraei and M. R. Iravani, "Power management strategies for a microgrid with multiple distributed generation units," *IEEE Trans. Power Syst.*, vol. 21, no. 4, pp. 1821–1831, Nov. 2006.
- [7] A. G. Madureira and J. A. Pecas Lopes, "Coordinated voltage support in distribution networks with distributed generation and microgrids," *IET Renew. Power Generat.*, vol. 3, no. 4, pp. 439–454, Dec. 2009.
- [8] M. H. Nehrir, C. Wang, K. Strunz, H. Aki, R. Ramakumar, J. Bing, et al., "A review of hybrid renewable/alternative energy systems for electric power generation: Configurations, control, and applications," *IEEE Trans. Sustain. Energy*, vol. 2, no. 4, pp. 392–403, Oct. 2011.
- [9] R. Majumder, B. Chaudhuri, A. Ghosh, R. Majumder, G. Ledwich, and F. Zare, "Improvement of stability and load sharing in an autonomous microgrid using supplementary droop control loop," *IEEE Trans. Power Syst.*, vol. 25, no. 2, pp. 796–808, May 2010.
- [10] D. Westermann, S. Nicolai, and P. Bretschneider, "Energy management for distribution networks with storage systems—A hierarchical approach," in *Proc. IEEE PES General Meeting, Convers. Del. Electr. Energy 21st Century*, Pittsburgh, PA, USA, Jul. 2008.
- [11] A. Chaouachi, R. M. Kamel, R. Andoulsi, and K. Nagasaka, "Multi-objective intelligent energy management for a microgrid," *IEEE Trans. Ind. Electron.*, vol. 60, no. 4, pp. 1688–1699, Apr. 2013.
- [12] R. Palma-Behnke, C. Benavides, F. Lanas, B. Severino, L. Reyes, J. Llanos, et al., "A microgrid energy management system based on the rolling horizon strategy," *IEEE Trans. Smart Grid*, vol. 4, no. 2, pp. 996–1006, Jun. 2013.
- [13] R. Dai and M. Mesbahi, "Optimal power generation and load management for off-grid hybrid power systems with renewable sources via mixed-integer programming," *Energy Convers. Manag.*, vol. 73, pp. 234–244, Sep. 2013.
- [14] H. Kakigano, Y. Miura, and T. Ise, "Low-voltage bipolar-type DC microgrid for super high quality distribution," *IEEE Trans. Power Electron.*, vol. 25, no. 12, pp. 3066–3075, Dec. 2010.
- [17] D. Chen, L. Xu, and L. Yao, "DC voltage variation based autonomous control of DC microgrids," *IEEE Trans. Power Del.*, vol. 28, no. 2, pp. 637–648, Apr. 2013.
- [15] D. Chen, L. Xu, and L. Yao, "DC voltage variation based autonomous control of DC microgrids," *IEEE Trans. Power Del.*, vol. 28, no. 2, pp. 637–648, Apr. 2013.
- [16] L. Roggia, L. Schuch, J. E. Baggio, C. Rech, and J. R. Pinheiro, "Integrated full-bridge-forward DC-DC converter for a residential microgrid application," *IEEE Trans. Power Electron.*, vol. 28, no. 4, pp. 1728–1740, Apr. 2013.