



ISSN (Print) : 2320 – 3765
ISSN (Online): 2278 – 8875

International Journal of Advanced Research in Electrical, Electronics and Instrumentation Engineering

(An ISO 3297: 2007 Certified Organization)

Vol. 3, Issue 11, November 2014

Control of Photovoltaic Water Pumping System with Battery Storage

K. Rama Krishna Reddy, B.Surendra Babu

Associate Professor, S.V. College of Engineering, Tirupati, India

Assistant Professor, S.V. College of Engineering, Tirupati, India

ABSTRACT: Due to the continuous decrease of the solar cells cost, photovoltaic energy is used in diverse applications. The most important one is the batteries-coupled water pumping system powered by photovoltaic generators. The use of batteries allows the system to deliver a constant water flow during the low light periods and night. With the increased use of this application, more attention has been paid to their optimum utilization. Fuzzy logic controllers provide attractive features such as fast response, accuracy and good performance compared to the classical controllers. Next, a vector control of induction motor fed by a photovoltaic system is studied to improve its dynamic performance. The photovoltaic pumping system is composed of a PV generator, DC-DC converter, batteries, DC-AC converter, a vector controlled induction motor and centrifugal pump. The surplus energy produced by PV panels during light hours charges the batteries and the batteries in turn supply power to the pump during backup energy. A simulation study is presented under variable weather conditions and the results show the effectiveness of the studied method.

KEYWORDS: Photovoltaic system, Fuzzy logic controller, PV pumping, induction motor, battery

I. INTRODUCTION

The increasing of the world energy demand, motivate a lot of investments in renewable energy solutions. One of the renewable energy is solar energy. Photovoltaic energy which is free and abundant in most parts of the world has proven to be an economical source of energy in many applications. One of the most applications is the PV pumping system driven by electrical motors [1]. The average efficiency of the photovoltaic pumping system is still low. To increase the efficiency and reducing the motor temperature, the battery will be installed in the photovoltaic pumping system. The battery is necessary to store the surplus energy, when the power output of the solar generator is greater than the load power. As the backup, when the power output of the solar generator is smaller than the load, the some energy is taken from the battery [2].

To maximize the efficiency of the photovoltaic energy system, it is necessary to track the maximum power point of the PV array. Many tracking control strategies have been proposed such as: Perturb and Observ (P&O), incremental conductance, curve-fitting method and open-circuit voltage PV generator method [2-6]. In many references the effectiveness of a fuzzy logic controller is shown [2-5] compared to the (P&O) method. It has the advantages of being robust, design simplicity and minimal requirement for accurate mathematical model.

Several authors present much attention to the study of the dynamic performance of the photovoltaic pumping systems. A. Terki and al [7] presented an analysis of the dynamic performance of a permanent magnet brushless DC motor controlled through a hysteresis current loop. Betka [8] presented the performance optimization of an asynchronous motor associated at a PV generator. Recently, vectorial command of induction motor pumping system supplied by photovoltaic generator was studied by Makhlof and al [9]. In H. Hadi [10], the photovoltaic pumping system with battery is proposed to reduce the overheating of the motor temperature and increase the efficiency. The battery is installed as the storage of the surplus energy and backup energy.



International Journal of Advanced Research in Electrical, Electronics and Instrumentation Engineering

(An ISO 3297: 2007 Certified Organization)

Vol. 3, Issue 11, November 2014

In this work, Battery-coupled water pumping systems consist of photovoltaic (PV) panels, DC/DC converter, batteries, AC motor and pump controller. A vector control method has been studied to improve the dynamic performance of the photovoltaic pumping system with batteries storage. Fuzzy logic (FL) speed controller is used; it gives robust performance under variation of environmental conditions and load demand. In order to optimize the photovoltaic energy generation, P&O and FLC techniques are applied to the studied system and a comparison is made. The modelling of the different parts of the photovoltaic pumping system with batteries is given and the simulation results are presented.

II. SYSTEM DESCRIPTION

Fig.1 shows the photovoltaic pumping system with batteries used in this paper. It includes photovoltaic array generator, DC/DC converter, batteries, DC/AC converter and induction motor coupled to a centrifugal pump. The system aims are to ensure a maximum operating of the photovoltaic array with fuzzy logic controller (FLC) and to improve the dynamic performance of the PV pumping system with fuzzy logic speed controllers. Due to the fluctuation nature of photovoltaic energy source, batteries are added as the storage of the surplus energy and backup energy.

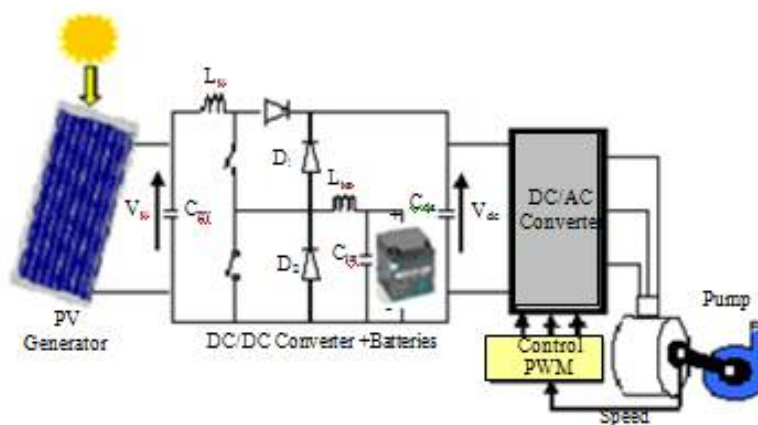

Fig.1: Structure of a global photovoltaic pumping system.

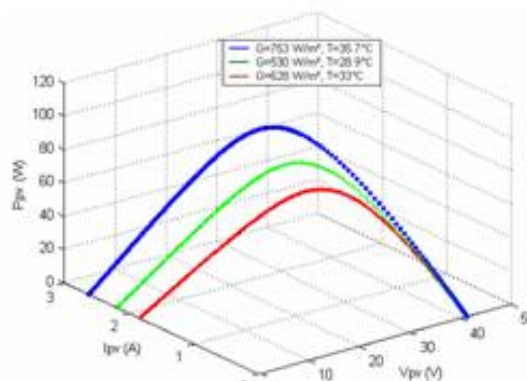

Fig.2: Experimental PV panel I_{PV} - V_{PV} - P_{PV} 3-D characteristic curves



ISSN (Print) : 2320 – 3765
ISSN (Online): 2278 – 8875

International Journal of Advanced Research in Electrical, Electronics and Instrumentation Engineering

(An ISO 3297: 2007 Certified Organization)

Vol. 3, Issue 11, November 2014

From these characteristics the non-linear nature of the PV array is apparent. Therefore, an MPPT algorithm must be incorporated to force the system to always operate at the maximum power point (MPP). We introduce a fuzzy logic controller to determine the operating point.

B. ELECTRICAL MODEL OF BATTERY

The system of storage is composed of four lead-acid batteries of 12 V, 92 Ah inter-connected in series to have 48 V. In practice, the determination of the batteries' impedances is often made on stationary behaviour. The basic principle is to impose on the battery an excitation in voltage or current in order to deduce in response to this excitation, an Ohmic representation of its internal state [4]. The battery behaves as complex impedance with a resistance R_{batt} and a reactance X_{batt} to this disturbance. The obtained values are: $R_{batt} = 0.756\Omega$, $X_{batt} = 0.072\Omega$ and $C_{batt} = 44.2\text{mF}$. These values change according to the state of charge of the battery.

C. OPERATING OF THE DC/DC CONVERTER

The DC/DC converter allows maximum utilization of the photovoltaic array and controls a power-flow to ensure a continuous delivery of energy to have the desired water flow, whatever environmental conditions variations. In the last task, we can distinguish two cases. The Batteries charge case: in this case the PV arrays generate sufficient energy to have the desired constant water flow load and charge battery. The power compensation case: in this case the energy available in PV arrays is not sufficient to supply the motor pumping system to have the desired water flow; the battery bank supplements the required energy.

D. INDUCTION MACHINE MODEL

The mathematical model of the induction machine is given by equations.11 [9,11]. Where R_s , L_s , R_r and L_r are the stator and rotor phase resistances and inductances respectively, M is the magnetizing inductance and ω_s and ω_r are the stator and rotor pulsations respectively. Besides, V_{sd} , i_{sd} , V_{sq} and i_{sq} are the d-q stator voltages and currents respectively. i_{rd} and i_{rq} are the rotor currents, along the d and q axis. The electromagnetic torque (T_e) developed by the induction machine is expressed as follows, where p the pair pole number of the machine.

$$T_e = p.M.(i_{rd} \cdot i_{sq} - i_{rq} \cdot i_{sd}) \quad (10)$$

E. CENTRIFUGAL PUMP MODEL

The head flow rate $H(Q)$ characteristic of a mono- cellular centrifugal pump is obtained using Pleider-Peter- man model [1], [9]. The multi-speed family head-capacity curves are given in [1] and can be expressed approximately by the following equation:

$$H = a_0\omega^2 - a_1\omega Q - a_2\omega Q^2 \quad (12)$$

Where a_0 , a_1 , a_2 are the coefficients generally given by the manufacturers [1]. The hydraulic power and the resistive torque are given by:

$$P_H = \rho.g.Q.H \quad (13)$$



International Journal of Advanced Research in Electrical, Electronics and Instrumentation Engineering

(An ISO 3297: 2007 Certified Organization)

Vol. 3, Issue 11, November 2014

$$T_r = k_r \omega + C_s \quad (14)$$

Where Q is the water flow (m^3/s), H is the manometric head of the well (m), ρ is the density (Kg/m^3) and g is the gravity (m/s^2). The Centrifugal pump parameters and canalisation parameters used in simulation are given in [1].

III. MPPT CONTROL ALGORITHMS

This method is based on the fact that ($dP_{pv} / dV_{pv} = 0$) at the MPP. The control scheme is shown in figure.3 and the inputs to the FLC are the power and the voltage variation (ΔP_{pv}), (ΔV_{pv}). The FLC measures the PV voltage and power and then perturbs the operating voltage by an favourable increment ($\Delta V_{pv,ref}$). This last is increased or decreased in a small or respectively large way in the direction which makes it possible to track the maximum power P_{pv} . The MPPT fuzzy logic controller consists of three main modules: the fuzzification process, the inference and the defuzzification process. The membership functions values are assigned to the linguistic variables. The inputs and output variables are triangular and have seven fuzzy subsets. The control rules are indicated in reference [4] and the defuzzification uses the centre of gravity.

$$P_{pv} \\ P_{pv} [k] \\ + \Delta P_{pv}$$



International Journal of Advanced Research in Electrical, Electronics and Instrumentation Engineering

(An ISO 3297: 2007 Certified Organization)

Vol. 3, Issue 11, November 2014

$\Phi_{rq} = 0$, the expression of the electromagnetic torque

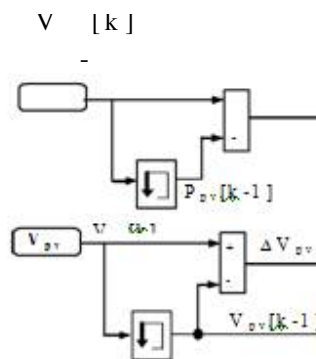

Fig.3: Structure of

IV. VECTOR CONTROL STRATEGY

Finally, as the chosen frame implies becomes:

$$T_e = p \cdot \frac{M}{L_r} \cdot \Phi_r \cdot i_{sq} \quad (15)$$

The rotor flux as a function of the current i_{sd} and the rotor time constant $T_r=L_r/R_r$ is given by the following expression:

$$\Phi_r = \frac{M \cdot i_{sd}}{1 + T_r \cdot s} \quad (16)$$

Where: s represents the derivative operator.

The knowledge of ω_s , by using the internal angular relation $\omega_s = \omega_r + p \cdot \Omega$ and the mechanical speed of the machine Ω is measured continuously; the speed of the rotor field is estimated by the following expression:

$$\omega_r = \frac{M \cdot i_{sq}}{T_r \cdot \Phi_r} \quad (17)$$



ISSN (Print) : 2320 – 3765
ISSN (Online): 2278 – 8875

International Journal of Advanced Research in Electrical, Electronics and Instrumentation Engineering

(An ISO 3297: 2007 Certified Organization)

Vol. 3, Issue 11, November 2014

Then, ω_s can be written in the following way:

$$\omega_s = \frac{M \cdot i_{sq}}{T_r \cdot \Phi_r} + p \cdot \Omega \quad (18)$$

PI fuzzy logic controller is used for the speed control. It improves control robustness and do not need exact mathematical models. This controller gives us a fast response compared to the classical PI [2].

V. NUMERICAL SIMULATION OF THE GLOBAL SYSTEM

A dimensioning is made to determine the size of PV panel of the PV pumping system. It is composed of (08) photovoltaic panel of 110W connected in series. Various simulations evaluate the performances of the system. The MPPT is controlled by using FLC. In order to test the robustness of the FLC algorithm, a comparison is made with the conventional (P&O) method under the STC conditions. Figs.(5.(a)-(b)) presents waveform of PV voltage for the two MPPT controllers (P&O and FLC). The FLC gives us a fast response compared to P&O method which requires much time to track the MPP and presents oscillations around the MPP at a steady state.



ISSN (Print) : 2320 – 3765
 ISSN (Online): 2278 – 8875

Inter

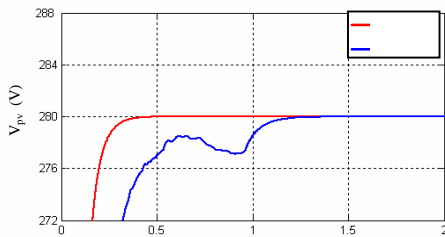

Advanced Research in Electrical,
 Automation Engineering

(Certified Organization)

November 2014

FL_PI
 Cla_PI

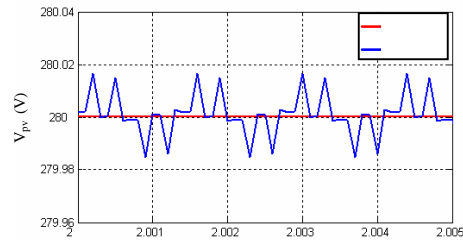

FLC P&O

FLC P&O

t (s)

t (s)

Fig.4: Waveform of photovoltaic voltage:(a). Transitional state, (b). Steady state

Other simulation results are carried out under random variation of environmental conditions to verify the ability of the photovoltaic pumping system with batteries to give a constant and desired water flow in accordance to the user demand. A vector control based on fuzzy logic controller of the induction motor, with optimization is used.

The reference speed is calculated from a reference power which is function on the water flow. The reference power is obtained from the available maximum photovoltaic power and the batteries which compensate the power deficit to provide a continuous delivery of energy to the motor pump. Simulation results using the vector control strategy are given. The flux and V_{dc} reference values are applied. These ones are: $\Phi_d - ref = 0.8Wb$; $V_{dc} = 465V$.

The control strategy is tested through the variations of solar radiation and temperature. The solar radiation varies up from 570 to $985W/m^2$ (fig.5) and temperature varies up from 22.5 to $37^\circ C$ (fig.6). The corresponding optimal voltage V_{pv} obtained from the fuzzy logic controller is represented in Fig.7. The FLC determines quickly the optimal operating voltage even when the operating environmental conditions change rapidly and in a wide range. In Fig. 8, the maximum power tracked from the PV array is shown. Fig. 9 shows the DC voltage waveform in the output of the DC converter (Shopper), it is well controlled.



International Journal of Advanced Research in Electrical, Electronics and Instrumentation Engineering

(An ISO 3297: 2007 Certified Organization)

Vol. 3, Issue 11, November 2014

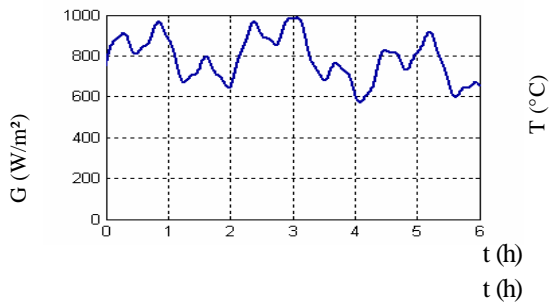

Fig.5: Solar radiance.

Fig.6: Temperature.

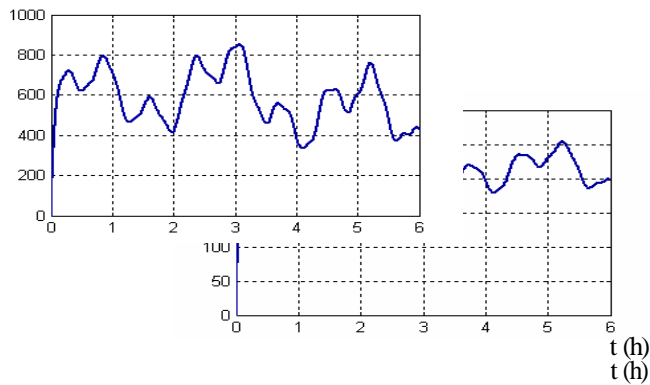

Fig.7: Photovoltaic voltage.

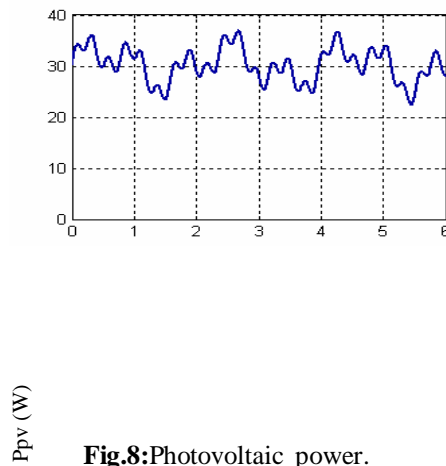
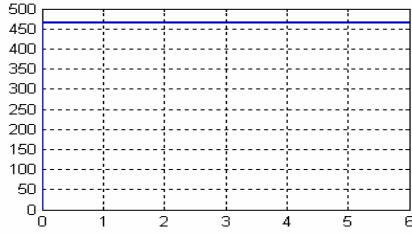

Fig.8: Photovoltaic power.



ISSN (Print) : 2320 – 3765
ISSN (Online): 2278 – 8875

Interr



Advanced Research in Electrical, Automation Engineering

(Certified Organization)

November 2014

t (h)

Te (Nm)

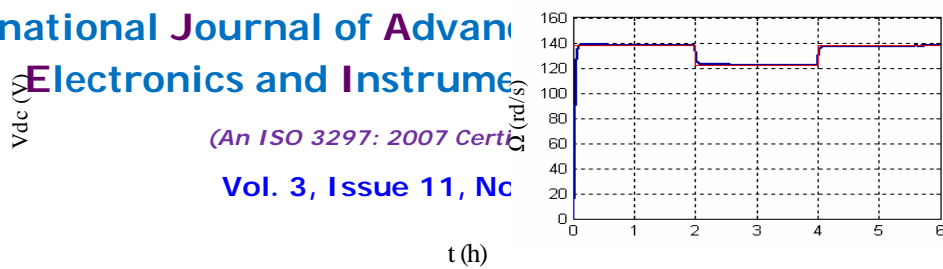
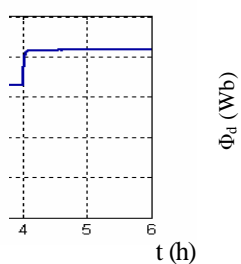
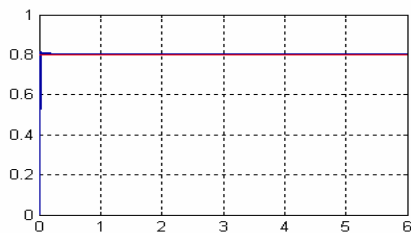

Fig.9: Generated DC voltage.

Fig.10: The speed of the induction machine.



i_d (A)



ISSN (Print) : 2320 – 3765
ISSN (Online): 2278 – 8875

International Journal of Advanced Research in Electrical, Electronics and Instrumentation Engineering

(An ISO 3297: 2007 Certified Organization)

Vol. 3, Issue 11, November 2014

t (h)

Fig.11: Electromagnetic torque

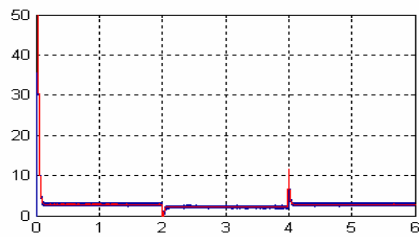
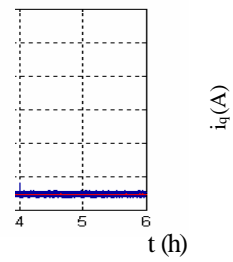

Fig.12: Rotor flux





International Journal of Advanced Research in Electrical, Electronics and Instrumentation Engineering

(An ISO 3297: 2007 Certified Organization)

Vol. 3, Issue 11, November 2014

t (h)

Fig.13: Stator current d axis component.

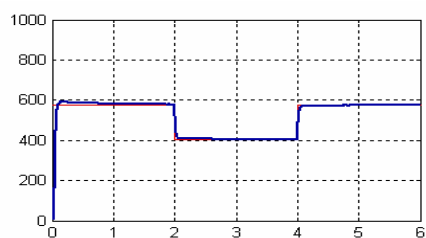
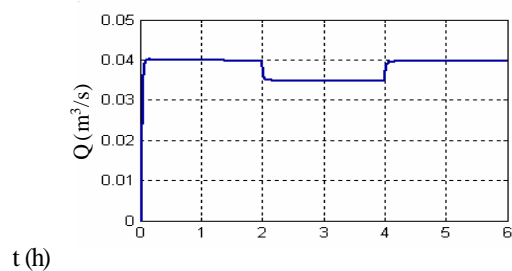

Fig.14: Stator current q axis component.



International Journal of Advanced Research in Electrical, Electronics and Instrumentation Engineering

(An ISO 3297: 2007 Certified Organization)

Vol. 3, Issue 11, November 2014

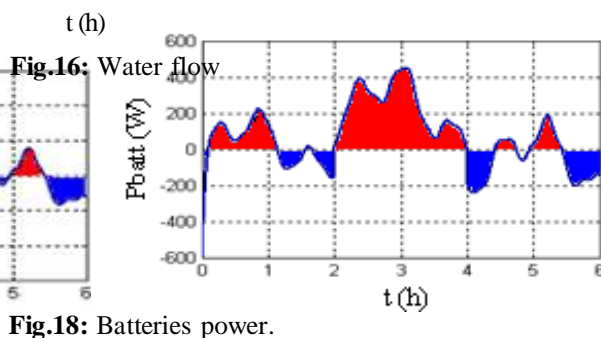
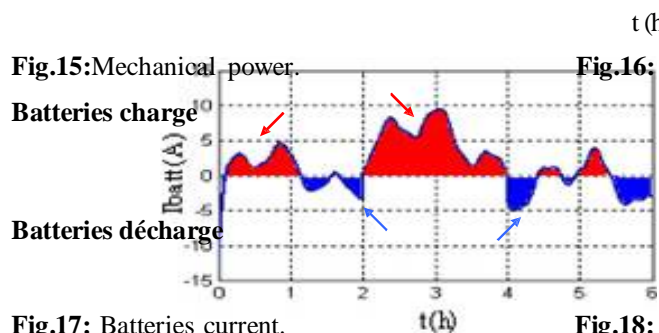



ISSN (Print) : 2320 – 3765
ISSN (Online): 2278 – 8875

International Journal of Advanced Research in Electrical, Electronics and Instrumentation Engineering

(An ISO 3297: 2007 Certified Organization)

Vol. 3, Issue 11, November 2014

Fig. 10 shows the variation of the speed which is determining from the reference power imposed by the desired water flow. This, last changes from (0.04 to $0.035\text{m}^3/\text{s}$) in respectively 2h and 4h. The step's profile is used to express the operating modes of the PV pumping system (batteries charge mode and power compensation mode). The corresponding speed varies from 137 rd/s to 122 rd/s it introduces a variation of the electromagnetic torque of the induction machine as shown in Fig. 11. Fig. 12 shows the waveform of the rotor flux. The response of the rotor flux is fast further to the change of the speed. Fig. 13 presents the stator current along the d-axis (i_{sd}) which is maintained constant independently of the q-axis current (i_{sq}) (Fig. 14). It may be noted that the waveform of the current i_{sd} is similar to that of the rotor flux. On the other hand, the waveform of the current i_{sq} shows the influence of the variation of the speed and the electromagnetic torque of the induction machine.

Fig. 16 shows the waveform of the water flow, it is maintained constant whatever environmental conditions variations. Figs. (17, 18) show batteries current and power. When PV power is sufficient to pump the desired water flow, the batteries will charge (batteries charge mode). During periods of insufficient generation, the battery bank postpones its recharge cycle and supplements the generation at the expense of its stored energy (power compensation mode).

VI. CONCLUSION

This paper has presented a control and simulation of water pumping system with battery storage powered by photovoltaic generators. The fuzzy logic controller was used to achieving the maximum power possible from a PV generator with fast response and good transient performances, whatever the variation of solar radiance and temperature. A vector controlled of the induction motor present good performances in speed response. The simulation results show that the system can deliver a constant water flow even when environmental conditions change. The electric current produced by PV panels during light hours charges the batteries and the batteries in turn supply power to the pump anytime water flow is needed.

REFERENCES

- [1] R. Chenni, L. Zarour, A. Bouzid and T. Kerbache (2006), "Comparative study of photovoltaic pumping systems using a permanent magnet synchronous motor (PMSM) and an asynchronous motor (ASM) ", Rev. Energ. Ren. Vol. 9, pp.17 – 28.
- [2] Lalouni S, Idjdarene K, Rekioua D (2012), "Vector Control based on fuzzy logic controller of Induction Motor for Photovoltaic Pumping System", in Proc. IREC 2012, Tunis, 20-22 december, pp:1-6
- [3] Salas V., Olias E., Barrado A., Lazaro A (2006) " Review of the Maximum Power Point Tracking Algorithms for Stand-Alone Photovoltaic Systems", Solar Energy Materials & Solar Cells, Vol. 90, No.11, pp.1555-1578.
- [4] Lalouni S, Rekioua D, Rekioua T, Matagne E (2009) "Fuzzy logic control of stand-alone photovoltaic system with battery storage", Journal of Power Sources, Vol.193, No.2, pp.899–907.
- [5] Simoes M.G., Franceschetti N.N (1999) "Fuzzy optimization based control of a solar array", IEE Proc. Electr. Power Appl., Vol. 146, No.5, pp.552-558.
- [6] Patcharaprakiti N., Premrudeepreechacharn S., Sriuthaisiriwong Y (2005) "Maximum power point tracking using adaptive fuzzy logic control for grid connected photovoltaic system". Renewable Energy, Vol. 30, No.11, pp.1771-1788
- [7] A. Terki, A. Moussi, A. Betka, N. Terki (2012) "An improved efficiency of fuzzy logic control of PMBLDC for PV pumping system", Applied Mathematical Modelling, Vol.36, No.3, pp. 934–944.
- [8] A. Betka and A. Moussi (2004) "Performance Optimization of a Photovoltaic Induction Motor Pumping System", Renewable Energy, Vol. 29, pp. 2167 – 2181.
- [9] Messaoud Makhlof, Feyrouz Messai, Hocine Benalla (2011) "vectorial command of induction motor pumping system supplied by a photovoltaic generator", journal of electrical engineering, Vol. 62, No.1, pp: 3–10.
- [10] Harsono Hadi (2003) "Photovoltaic Water Pump System", Doctorat thesis, in Kochi University of Technology.
- [11] M. Arrouf, N. Bouguechal (2003) "Vector control of an induction motor fed by a photovoltaic generator", Applied Energy, Vol, 74, No.1, pp: 159–167.

DOI:10.15662/IJAREEIE.2014.0311104



ISSN (Print) : 2320 – 3765
ISSN (Online): 2278 – 8875

International Journal of Advanced Research in Electrical, Electronics and Instrumentation Engineering

(An ISO 3297: 2007 Certified Organization)

Vol. 3, Issue 11, November 2014

- [12] Manoj Kumar, Dr. F. Ansari and Dr. A. K. Jha, “Analysis and Design of Grid Connected Photovoltaic System” International Journal of Electrical Engineering & Technology (IJEET), Volume 3, Issue 2, 2012, pp. 69 - 75, ISSN Print : 0976-6545, ISSN Online: 0976-6553 Published by IAEME.
- [13] T.Balamurugan, Dr.S.Manoharan , P.Sheeba and M.Savithri, “Design A Photovoltaic Array With Boost Converter Using Fuzzy Logic Controller” International Journal of Electrical Engineering & Technology (IJEET), Volume 3, Issue 2, 2012, pp. 444 - 456, ISSN Print : 0976-6545, ISSN Online: 0976-6553 Published by IAEME.
- [14] Jadhav Sumedh Damodhar and Phatale Aruna Prashant, “Microcontroller Based Photovoltaic Battery Charging System With Buck Converter” International Journal of Electrical Engineering & Technology (IJEET), Volume 3, Issue 1, 2012, pp. 123 - 130, ISSN Print : 0976-6545, ISSN Online: 0976-6553 Published by IAEME.