



e-ISSN: 2278-8875

p-ISSN: 2320-3765

International Journal of Advanced Research

in Electrical, Electronics and Instrumentation Engineering

Volume 11, Issue 1, January 2022

ISSN INTERNATIONAL
STANDARD
SERIAL
NUMBER
INDIA

Impact Factor: 7.282

☎ 9940 572 462

☑ 6381 907 438

✉ ijareeie@gmail.com

@ www.ijareeie.com



Environmental Monitoring Using Internet of Things

Prof. (Dr.) Vijay Mane, Riddhi Selkar, Varda Shelgaonkar, Bhavin Shah, Alfisher Sayyed,

Department of Electronics & Telecommunication Engineering, VIT, Pune, India

ABSTRACT: The Internet of Things (IoT) is known to play a critical capacity in regular daily existence the entire way through inescapable sensor correspondence networks that epitomize our general climate. Such framework is gives the plan capacity to screen fundamental actual occasions produced information that can be moved and put away in the cloud from which it is feasible to share this data by means of utilization and choice is made to make a move for a happened occasion. Ecological Monitoring framework uses sensors for encompassing area moistness and temperature. These information could be used to animate transient conduct like gadget becoming hot or getting cool down and other long haul insights of the gadgets. The detected information will be sent to cloud space, and the cloud is gotten to by a Smartphone application and results are introduced to end clients. The review is done the sort sensors, microcontroller and its ability, investigation of various kind's economical organization arrangement for ceaseless information assembling and checking. Different instruments used to investigate the information put away on the cloud.

KEYWORDS: Arduino, sensors, cloudstorage, IOT

I. INTRODUCTION

The Internet of Things (IoT) is set to modernize our environment by letting us to control and monitor essential phenomenon in our surroundings via using devices capable of capturing data, evaluating and wireless transmission of information to storage server, like the cloud, which collects, assesses and provides these data in a meaningful way. From the cloud this information can be obtained, based on appropriateness and demands, via numerous front end user interface design such as mobile and web applications. The Internet strikes at the heart of this transition and plays a big part in secure, effective, and fast transmitting data between fog and applications and end users. The definition of a traditional end user or server in the Internet is changed in this new paradigm and hosts consist of the devices or objects therefore the term Internet of Things. The "devices and sensor" will detect and transmit data such as temperature, pressure, humidity, sound, emissions, object tracking, vitality of the patient. Environment aspects tracking is an important IoT system that mainly includes data collection through the sensing system, as well as reviewing this data for successful short-term measures such as remote management of heating or cooling devices and long-term data interpretation and observations. The Internet of Things (IOT) has proven extremely successful and is expanding rapidly in all fields. Automated monitoring system will control and monitors by using the data processing micro - controller, data gathering sensors, and wireless data transmission sensor network. Nodes have sensing and transmission/ receiving capabilities on the wireless sensor network. Large number sensor nodes are either randomly fix on the confined area or are based on the structure defined. This paper focuses mainly on the diverse wireless sensor network issues considering such as higher energy consumption in the sensor nodes leads to node failure after some communications, reduction in data transfer rate causes network suffering, network destabilization leads to loss of data, long-range data transfer may result in even more energy, number of nodes can increase node traffic

II. LITERATURE REVIEW

Recently, IoT has began to emerge as new area that has naturally drawn huge attention of both business enterprise capital firms and tech firms, likely to result in a variety of research and commercial enterprise programs. Smart power station, smart city, intelligent wearable evinces and automated home are some of the current tending applications that have garnered attention. Nearly all of the different IoT applications engage with collection of the sensed data from sensors and transducers that are usually fond of to a microcontroller next to with wired or wireless transmission to just a limited system or on a cloud that brings the data to requires information format that can be used efficiently. The research actions include fabrication of smart devices, appropriate wireless devices, development boards, developing network protocols, applications and much more. We studied recent work accomplished in developing important and informative implementations using cost-effective boards likewise raspberry pi series, Arduino series. as part of our



project. Most of those common applications built using these boards include automation of home, weather and environmental monitor systems, patient monitoring systems, etc. The Internet of Things gives many choices to the society as well as from our project we provide and demonstrate the endurance of IoT by using Thingspeak which really is able to contribute the services to meet the needs of developing large numbers of IoT applications and offering to help to incorporate them on the public platform. matlab Feature in Thingspeak and vice versa offers an even in-depth analysis and research of gathered data at a significant point to manage the local environment where measuring parameters is essential. finally , we culminate that microcontrollers will reduce and disappear into the environment and that IoT tends to lead will be universal everywhere and in all perspectives and the Thingspeak IoT Web service is certainly an intriguing web-based technology that includes the capacity to impact the engineers' expectations . IOT is behind this. The system build to monitoring and controlling with sensors the climatic conditions like intensity of light, surrounding temperature and humidity, concentration of CO2 and sends the data to the web page and then plots the sensor data as visual facts and figures. The Internet of Things (IoT) is known to play a significant role in everyday life through widespread sensor network systems that encompass our surroundings. Such systems are developed to measure significant physical occurrences generating data which can be transferred and stored in the cloud from where it is possible to access this information through applications and further measures can be taken . This article describes an environmental control system that uses sensors for atmospheric temperature and humidity to introduce and impact. Such data could be used to activate short-term behavior such as automated heating or cooling equipment control or the long-term status. The analyzed data would be transferred to server space, and an Android program would enter the web, and end-users will be provided with the findings. The machine uses the Arduino Board frame, Humidity and temperature sensor, Wi-Fi module, which sends data to the ThingSpeak free IoT API service and analyzes and stores data there. Creation of an Android framework that uses the rest API web application to control data in the cloud and view end-user performance. Experimental tests indicate how efficient the device is working. . Since we all know that we live in an era of 4G technology in which everyone uses the internet as part of daily activity. Now the internet has becoming everyone's necessity, this is because most of the people use wearable gadgets based on the internet of things kind of devices. basically in this paper they spoke about Sensor nodes that are used in remote location for monitoring temperature & humidity. They have studied the various exiting technology is based on the system as per this paper. However according previous research studies they found numerous issues that also need to be solved. . The devices are provided capability for sensing and transmitting data, for example, temperature , weight, stickiness, disturbance, tainting, object area, tenacious vitals, etc. Environmental testing is a vital IoT implementation that also includes monitoring the embracing status and showing this information for feasible present moment steps, for example, Control of warming or cooling of devices remotely, and long-haul information reviews and metrics. An everincreasing number of people are interconnected far and wide with the advent of fast Internet. Network of Things (IoT) takes this a step further and puts together people and computer devices that can speak to each other . The Wireless sensor network congestion is depends on number of devices in the area and network topology, for example loss of data is much more in case of star topology than mesh topology, the network reliability is depends on the sensor node location in the field (line of sight), signal strength is dependent on the node distance from the control node or coordinator node, power consumption is base on the technology (bluetooth, zigbee, wi-fi, gsm, or lora) and also the signal strength. The network connection has a limitation on improved battery life, high bandwidth size, smaller data transfer distance then the choice is wsn with Bluetooth. It's ideal for improved battery life, short range data transfer, and low wsn bandwidth using zigbee. Network requires extensive data transmission (image or video), high bandwidth and data transmission rate without battery life constraints, and wsn using Wi-Fi is preferable. Network needs high bandwidth and network throughput with no cost and battery constraints then gsm is a choice. Network needs long-range low-power data transmission (better battery life) and low data rates are not a problem so wsn with lora is sufficient Next revolutionary technology which connects devices together and makes the system smarter has been recognized on the Internet of Things. wata generated physical aspect and these systems have been developed to track and further submit to cloud for adequate use. humidly aided, and temperature control system is built in this paper cloud. monitored data will be used to trigger certain behavior such as controlling subsequent machines. The device was integrated with the Wi-Fi module (ESP8266) Arduino Uno, dht 11 Sensor. data transmitted to ThingSpeakIoT service cloud to be further processed and evaluated.. water is the key factor for the agriculture. We need to save the water for the future, due to be deficient in of rainfall and depletion of water resources. This paper mainly emphasizes the insight in water conservation by using soil moist prediction through sensor, protecting farm area by using PI camera and PIR sensor connected to controller device run using solar energy and also ac power source (ac to dc adapter) to constantly transmit data even on power cutting. The Internet of Things is the idea used to communicate effectively with the crop by knowing plant requirements. Assessing and tracking soil moisture can help save more water and crops get the amount of water required to grow properly. The farmers can keep track of soil moisture through a Smartphone by using this system. The farmer is allowed to control the flow of water through the mobile app, supervise the crop growth by posting a snapshot using the



camera and the system helps the farmer by sending alerts about the intruder (humans and animals) using the speaker pir sensor and trigger the camera to capture the intruder image and send it to the user.

III.METHODOLOGY/COMPONENTS

A. Materials/Components

1. Arduino UNO
 2. 10WATT1K
 3. L293D
 4. LDR
 5. LED-RED, YELLOW
 6. LM35
 7. MOTOR
 8. POT-HR
 9. RELAY
- ULN2003A

1. Arduino UNO -

Arduino is an opensource physical programmable microcontroller board, it is also referred as a software , or IDE i.e. Integrated Development Environment which is connected through B type USB and it runs on the specific connected PC and also it allows to write and upload the code to that circuit, it has sets of computerized I/O sticks which is interfaced to some sheets called as development sheets or safeguards, this sheets had 14 I/O pins, it has working voltage of 5V and 7-12V input voltage.

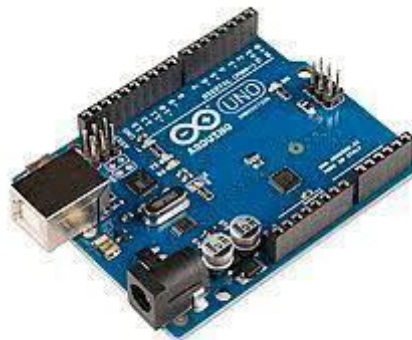

Fig .1. Arduino

2. 10 WATT 1K - RESISTOR

Resistors in circuit are the passive two-terminal electrical components, here are 1 * 1K ohm 10 Watt wire wound resistor.

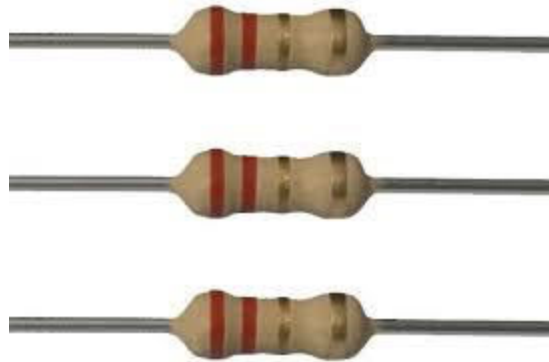

Fig .2. Resistors

3. L293D

It is a popular 16 pin Motor Driver IC, i.e. simultaneously drives two DC motors in direction and it receives signals from microprocessor and then transmits the relative signals to motor driver and it has two voltage pins like a bridge circuit with two channels with voltage range 4.5V to 36V.



Fig .3. IC L293D

4. LDR

It is a variable resistor which varies according to the intensity of light falling on it.



Fig .4. LDR



5. LED-RED, YELLOW

Used as indicator lamps, replacing small incandescent bulbs, they are of low intensity.



Fig .5. LEDs

6. LM35

It is used to measure temperature with an electrical output and in the immediate surroundings of the sensor and here output is an analog voltage.

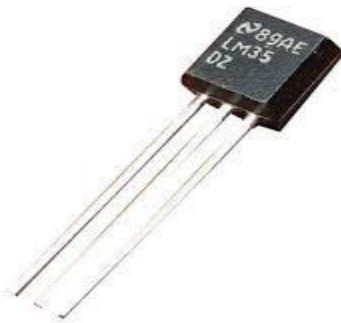

Fig .6. LM35

7. MOTOR

It is connected in a way to control spinning direction of DC motor and control speed and also acts as interface.



Fig .7. Motor



8. POT-HR

It provides a varying amt of resistance by passing voltage through it.

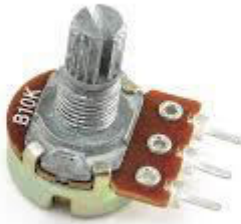

Fig .8. Potentiometer

9. 9. RELAY

It uses 5v which is outputted from an arduino pin which acts as an electrical switch.



Fig .9. Relay

1110. ULN2003A

It is a array of 7 NPN Darlington transistors and it capable of 500mA - 50V output.



Fig .10. ULN2003A



B. Tools:

1. Proteus circuit simulator
2. Windows
3. Arduino IDE

Every part is associated with the necessary force of +5V. LM35 temperature sensor, a cooling fan, motor, LED are furthermore connected with the Arduino.

Temperature sensor recognizes the level of temperature, if it goes high DC fans gets on and at the point when the temperature goes low Without light, the LDR sensor resources and the bulb starts shining. By this way it will end up being easy to screen and control the system.

At the moment when the temperature goes beyond threshold signal is sent to turn on the fan with the temperature magnitude like Its HOT Turn On the FAN, 31.25 *C, when the temperature goes to the conventional level, the temperature sensor detects the temperature and sends the signal to stop the fan.

LDR sensor assesses light power. When sensor detects brightness beyond threshold then it sends the message to turn off the light LED, and vice versa. It gives message like Its BRIGHT turn OFF the LED. Moisture sensor senses the soddenness if it passes beyond threshold it sends message to turn off the pump and vice versa. It prints message on the virtual window Water level is low , turn ON the PUMP.

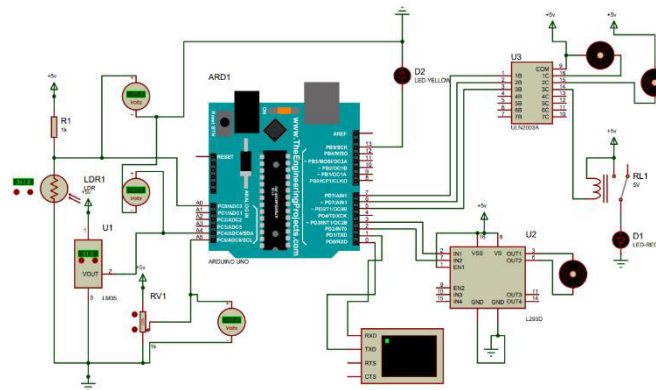

Fig .11. Circuit Diagram

IV. RESULTS AND DISCUSSION

Results are shown in the virtual window.

It shows both the monitored results and controlling signals along with the measures of temperature, brightness and water level.

```

Its HOT, Turn ON the FAN : 31.25 *C
Its BRIGHT, Turn off the LED : 472
Water level is LOW, Turn ON the Pump : 102
Its HOT, Turn ON the FAN : 31.25 *C
Its BRIGHT, Turn off the LED : 472
Water level is LOW, Turn ON the Pump : 102
Its HOT, Turn ON the FAN : 31.25 *C
Its BRIGHT, Turn off the LED : 472
Water level is LOW, Turn ON the Pump : 102
Its HOT, Turn ON the FAN : 31.25 *C
Its BRIGHT, Turn off the LED : 472
Water level is LOW, Turn ON the Pump : 102
    
```

Fig .12. Appliances OFF/ON



The project does have its limitations too. As it was a software semester, we couldn't convert the project into a real life project and couldn't come up with the necessary circuit offline.

Other issue with the project is power consumption may drain out the power supply attached to the arduino. Often in reality the arduino is seen to not handle so many sensors at one time.

In our design we have used common ground configurations for all sensor and arduino connections, which is not always physically safe.

Working with all these Sensors can be tricky as arduino gives priority to the first sensor being called in its code and this may have a cascading effect if that particular sensor fails.

IoT sending in shrewd climate applications may in any case confront various difficulties related to recognizable proof, information investigation, addressing security issues and giving interoperability ability among different kinds of climate depend perspective. However these troubles, it has more chances to add effect on the IoT markets and offer the bearing of future worldwide tasks in many portions of the climate.

V. CONCLUSION

Essentially, in this paper we focus on the past proposed strategies where we see that there are many examination openings that should be talked about. The paper tends to water wellbeing, air pollution, ecological observation, radiation location, synthetic defilement, normal risk, ranch guideline, squander the executives, etc. In smart Climate, IoT could likewise oversee and break down the ecological stream attributes on the both water, air and anticipated alterations which can trigger any human, creature and plant issues. Moreover, IoT plays a vital job in overseeing ecological harm, regular and non-catastrophic events, just as in controlling vegetation bosses in the climate.

REFERENCES

- [1] Deekshath MR, Dharanya MP, Kabadia MK, Dinakaran MG, Shanthini S. IoT based environmental monitoring system using arduino UNO and thingspeak. *International Journal of Science Technology & Engineering*. 2018;4(9).
- [2] Behera TM, Mohapatra SK, Samal UC, Khan MS, Daneshmand M, Gandomi AH. I-SEP: An improved routing protocol for heterogeneous WSN for IoT-based environmental monitoring. *IEEE Internet of Things Journal*. 2019 Sep 12;7(1):710-7.
- [3] Sunny AI, Zhao A, Li L, Kante Sakiliba S. Low-Cost IoT-Based Sensor System: A Case Study on Harsh Environmental Monitoring. *Sensors*. 2021 Jan;21(1):214.
- [4] Abraham S, Beard J, Manijacob R. Remote environmental monitoring using internet of things (iot). In 2017 IEEE Global Humanitarian Technology Conference (GHTC) 2017 Oct 19 (pp. 1-6). IEEE.
- [5] Cabra J, Castro D, Colorado J, Mendez D, Trujillo L. An IoT approach for wireless sensor networks applied to e-health environmental monitoring. In 2017 IEEE International Conference on Internet of Things (iThings) and IEEE Green Computing and Communications (GreenCom) and IEEE Cyber, Physical and Social Computing (CPSCom) and IEEE Smart Data (SmartData) 2017 Jun 21 (pp. 578-583). IEEE.
- [6] Khan N, Khattak KS, Ullah S, Khan Z. A low-cost IoT based system for environmental monitoring. In 2019 International Conference on Frontiers of Information Technology (FIT) 2019 Dec 16 (pp. 173-1735). IEEE.
- [6] Shah J, Mishra B. IoT enabled environmental monitoring system for smart cities. In 2016 international conference on internet of things and applications (IOTA) 2016 Jan 22 (pp. 383-388). IEEE.
- [7] Lazarescu MT. Design of a WSN platform for long-term environmental monitoring for IoT applications. *IEEE Journal on emerging and selected topics in circuits and systems*. 2013 Mar 7;3(1):45-54.
- [8] Mois G, Folea S, Sanislav T. Analysis of three IoT-based wireless sensors for environmental monitoring. *IEEE Transactions on Instrumentation and Measurement*. 2017 Mar 27;66(8):2056-64.
- [9] Jaladi AR, Khithani K, Pawar P, Malvi K, Sahoo G. Environmental monitoring using wireless sensor networks (WSN) based on IOT. *Int. Res. J. Eng. Technol*. 2017 Jan;4(1):1371-8.

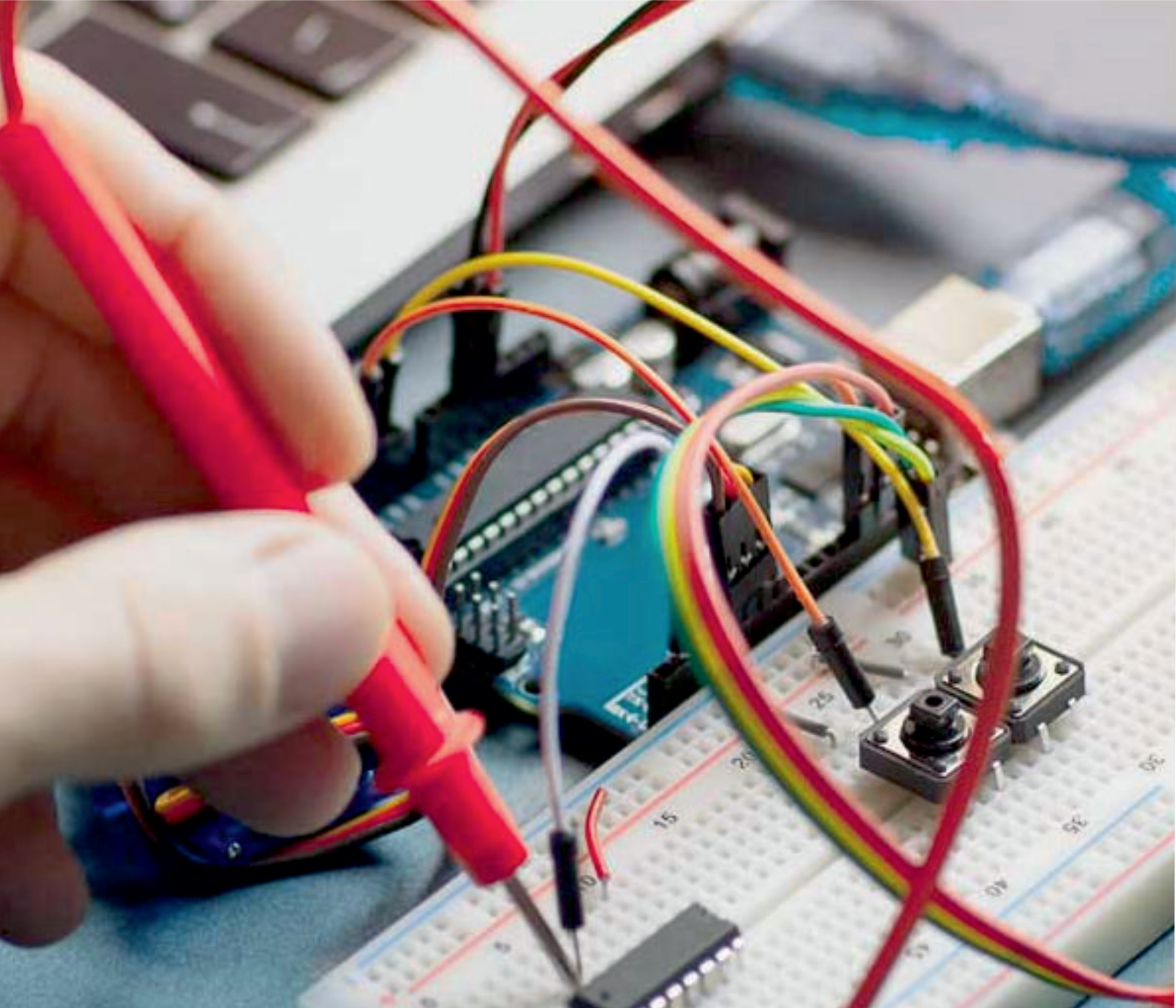

INNO SPACE
SJIF Scientific Journal Impact Factor
Impact Factor: 7.282



ISSN INTERNATIONAL
STANDARD
SERIAL
NUMBER
INDIA



International Journal of Advanced Research

in Electrical, Electronics and Instrumentation Engineering

 **9940 572 462**  **6381 907 438**  **ijareeie@gmail.com**



www.ijareeie.com

Scan to save the contact details