



ISSN (Print) : 2320 – 3765  
ISSN (Online): 2278 – 8875

# International Journal of Advanced Research in Electrical, Electronics and Instrumentation Engineering

(A High Impact Factor, Monthly, Peer Reviewed Journal)

Website: [www.ijareeie.com](http://www.ijareeie.com)

Vol. 9, Issue 3, March 2020

## IOT Based Distribution Transformer Monitoring System

Mr. D.Vinoth<sup>1</sup>, R.Ganapathi<sup>2</sup>, C.Dineshkumar<sup>3</sup>, C.Sathish<sup>4</sup>

Assistant Professor, Department of Electrical and Electronics Engineering, Muthayammal College of Engineering,  
Namakkal, India<sup>1</sup>,

UG Scholar, Department of Electrical and Electronics Engineering, Muthayammal College of Engineering,  
Namakkal, India.<sup>2, 3, 4</sup>

**ABSTRACT:** A recent huge interest in Machine to Machine communication is known as the Internet of Things (IOT), to allow the possibility for autonomous devices to use Internet for exchanging the data. This work presents design and execution of real time monitoring and fault detection of transformer and record key operation indicators of a dispersion transformer like load current, voltage, transformer oil and encompassing temperatures and humidity. They have to look at it continuously by using this project it can minimize working efforts and improve accuracy, stability, efficiency in this project, sensors are used to sense the main parameters of equipment such as voltage, current(over voltage, under-voltage, over current) this sensed data is sent to microcontroller and this controller checks parameter limits which further send to the IOT web server Adafruit software using Wi-Fi module of these data makes sure the right information is in hand to the operator and operator can make useful decisions before any catastrophic failure on basis of that data of parameters.

**KEYWORDS:** Real time monitoring, Distribution transformers, IOT (internet of things).

### I.INTRODUCTION

The internet of things [1] is about connecting the unconnected things. It allows for thing to accessible from the internet that historically have not been. The internet of things is able to improve quality of life for everyone by taking advantage of these connected thing and data produced. The billions of m2m connection make possible the everything in IOT. The process element leverages the connection between data thing and people to deliver the right information. To right thing or person, at the right time, it is these billions of connection that add value.

Distribution Transformers have a long life if they are operated under appraised conditions. However, their life is essentially decreased if they are overloaded, resulting in unexpected failures and loss of supply to an expansive number of customers hence affecting system unwavering quality. Overloading and ineffective cooling of transformers are the major significant reasons for failure in distribution transformers. C.Nagarajan et al [2,8,11]most power companies use Supervisory Control and Data Acquisition (SCADA) system for web-based monitoring of power transformers yet amplifying the SCADA system for online monitoring of distribution transformers is an a costly suggestion.

- 1) Distribution transformers are as of now observed physically where a man intermittently visits a transformer site for support and records parameter of significance. This type of monitoring can't give data about incidental over-load and overheating of transformer oil and windings. Every one of these variables can essentially decrease transformer life.
- 2) Normal transformer measurement system generally detects a single transformer parameter, for example, control, current, voltage, and stage. While some ways could recognize multi-parameter, the time of acquisition and operation parameters is too long, and testing pace is not sufficiently quick.
- 3) A monitoring system can only monitor the operation state or guard against steal the power, and is not able to monitor all useful data of distribution transformers to reduce costs

# International Journal of Advanced Research in Electrical, Electronics and Instrumentation Engineering

(A High Impact Factor, Monthly, Peer Reviewed Journal)

Website: [www.ijareeie.com](http://www.ijareeie.com)

Vol. 9, Issue 3, March 2020

- 4) Auspicious detection data will not be sent to observing centers in time, which cannot judge distribution transformers three phase equilibrium.
- 5) Detection system itself is not reliable. The main principle execution is the device itself instability, poor anti jamming capability, low measurement accuracy of the data.

According to the above requirements, we need a distribution transformer real-time monitoring system to detect all operating parameters operation, and send to the monitoring center in time. It leads to Online monitoring of key operational parameters of distribution transformers can provide useful information about the health of transformers which will help the utilities to optimally use their transformers and keep the asset in operation for a longer period. This will also help identify problems before any catastrophic failure which can result in a significant cost savings and greater reliability.

## II.BLOCK DIAGRAM

In the transformer side the voltage and the current are sensed and also the oil level, oil quality, temperature is sensed using the respective sensors and also the load is sensed using this efficiency of the transformer is easily identified. Finally all the data are sent to the receiver. Based on the load current, load will shed automatically .If any short circuit fire occurs it is sensed by the fire sensor provided. The transformer side block diagram is shown below

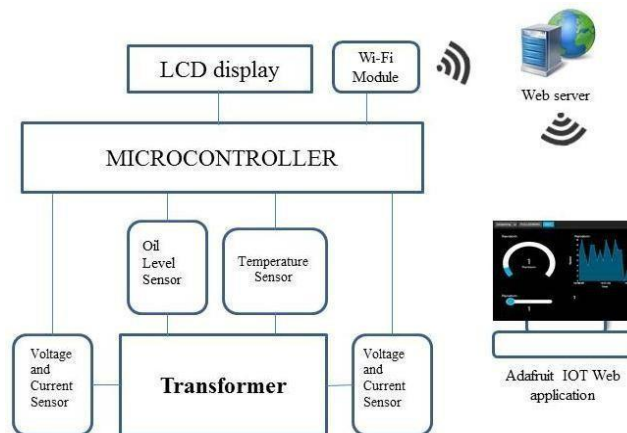

Fig.1: Block Diagram

### Circuit Diagram:

In this project two kind of basic circuits needed, one is current sensing and the other is voltage sensing circuit. Current is sensed through current transformer and the voltage is sensed through the potential transformer.

#### A. Voltage Sensing:

Below figure consist of 230V AC input supply. As microcontroller atmega16 can operates up to or less than 5V. Therefore, after 230V AC supply there is 230V/6V step down transformer is used and then rectified by rectifier circuit to change 6V AC into 6V DC. As we need less than 5V after these there is a voltage divider circuit is implemented to drop the voltage at certain level. So that the microcontroller can read the input side of main transformer.

# International Journal of Advanced Research in Electrical, Electronics and Instrumentation Engineering

(A High Impact Factor, Monthly, Peer Reviewed Journal)

Website: [www.ijareeie.com](http://www.ijareeie.com)

Vol. 9, Issue 3, March 2020

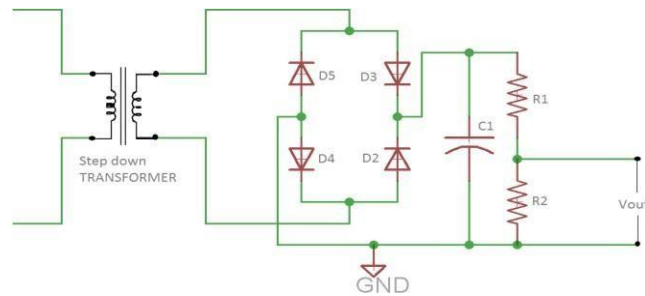

Fig.2: Voltage Sensor Diagram

### 1. STEP DOWN TRANSFORMER

It is used for reduce the voltage from the primary winding to the secondary winding.

### 2. RECTIFIER

A rectifier [2] is a circuit that converts AC signals to DC. A rectifier circuit is made using diodes. There are two types of rectifier circuits as Half-wave rectifier and Full-wave rectifier depending upon the DC signal generated.

### 3. VOLTAGE DIVIDERS

Resistor voltage dividers are commonly used to create reference voltages, or to reduce the magnitude of a voltage so it can be measured, and may also be used as signal attenuators at low frequencies. For direct current and relatively low frequencies, a voltage divider may be sufficiently accurate if made only of resistors; where frequency response over a wide range is required (such as in an oscilloscope probe), a voltage divider may have capacitive elements added to compensate load capacitance. In electric power transmission, a capacitive voltage divider is used for measurement of high voltage

$$V_{out} = V_{in} \cdot \frac{R_2}{R_1 + R_2}$$

### A. Current Sensing:

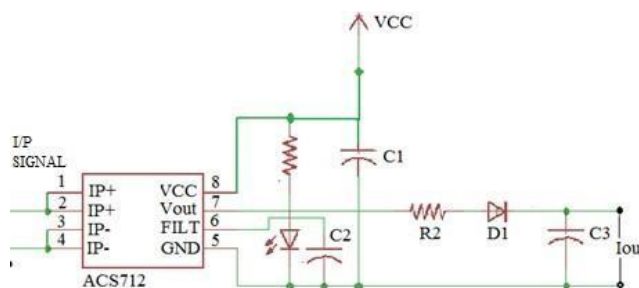

Fig.3: Current Sensor Diagram

The Allegro ACS712 provides [3] economical and precise Solutions for AC or DC current sensing in industrial, commercial, and communications systems. Typical applications include motor control, load detection and management, switch mode Power supplies and over current fault protection.

# International Journal of Advanced Research in Electrical, Electronics and Instrumentation Engineering

(A High Impact Factor, Monthly, Peer Reviewed Journal)

Website: [www.ijareeie.com](http://www.ijareeie.com)

Vol. 9, Issue 3, March 2020

## B. Microcontroller Interfacing With Power Supply:

The sensed current and voltage are sent to the microcontroller at mega16. It is a 16 bit microcontroller [4] ‘a’ refers to advance since it has inbuilt ADC (Analog to Digital Converter). The voltage and the current are sensed in analog values and are converted to digital values using ADC. The following diagram shows the overall circuit.

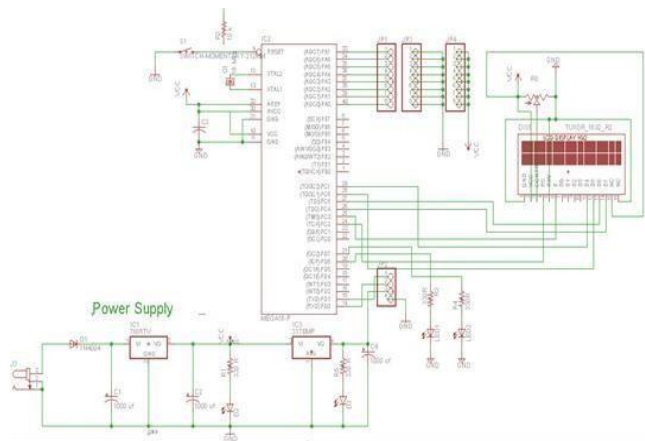

Fig.4: Microcontroller Interfacing with Power Supply

## C. Relay:

Usually a relay is used in a circuit as a magnetic switch to turn on a second circuit. A relay is an electromagnetic switch, which is activated when a small current is passed through its coil. The interesting fact is that this small current is capable of turning on a secondary circuit which works on much larger current. There are varieties of relay available in the electronics market each of them operates at different voltages. When you construct your own circuit you must consider the voltage ratings that will energize (trigger) it.

## III.HARDWARE DESIGN

The system hardware has three hardware modules as shown in Figure 1: embedded system designed around microcontroller, ESP8266 module and PC based Adafruit site. The embedded module is located at the transformer site. It is utilized to acquire process, display, transmit and receive the parameters of the power transformer. It is the link between the embedded system and IOT based Adafruit server. The third is utility module that has a PC based Adafruit site server. The server is attached to ESP8266 module transmits parameter data of the power transformer to Adafruit server.

It converts each reading to a compatible signals that can be read by the embedded system built-in ADCs (0-5 volts DC). Each circuit has two Op Amps and set of resistors to adjust the gain and the offset. The current and voltage have small transformers and rectifier circuits that convert and scale the current and voltage values to compatible levels with the Op Amps circuits. The controller block consists of a 16-bit microcontroller that has 8-channel analog to digital converter (ADC) and several digital input/output ports. The ADC is used to read the parameters, the built-in EPROM is used to host the embedded software algorithm that takes care of the parameters acquisition, processing, displaying, transmitting and receiving. The built-in EEPROM is used to save the online measured parameters along with their hourly and daily averages. The system is equipped with 2- lines 16 character each LCD and 16-LEDs that are used as pilot lights to indicate each parameter status. The microcontroller uses ESP8266 module for communication to upload information related to the transformer parameters and status. It send to a Adafruit server where it can be access or monitored through PC or any smart device.



# International Journal of Advanced Research in Electrical, Electronics and Instrumentation Engineering

(A High Impact Factor, Monthly, Peer Reviewed Journal)

Website: [www.ijareeie.com](http://www.ijareeie.com)

Vol. 9, Issue 3, March 2020

## IV. SOFTWARE ARCHITECTURE

Using the microcontroller native language, a software algorithm was developed and implemented to command the system operation. The algorithm starts by initializing the input/output ports data direction flow, set the ADC channels and reset all related memory locations that are going to be used in the operation. Then, it begins to command the system according to the following sequence: Rest all variable values 1000. Read currents, voltages and temperatures, Check for abnormalities. If any abnormality exists, send the information to Adafruit server where any Operation Engineer, technician or any authorized personnel can see it. Store values and display readings, Repeat the whole process again. The software algorithm takes about 500ms to acquire, process, transmit / receiver the information to ESP, module attached to the microcontroller and also display and update the LCD / LEDs pilot indicators. The required time to sending or receiving data to/from the esp8266 to/ from the utility personnel depends on the server speed. It varies from 2-1 seconds. The accuracy of the reading relies on the ADC resolutions, current and voltage transformers, signal conditioning circuit gain and offset. The microcontroller ADC resolution is + % least significant bit (LSB). It is about 10 mV on a 5000 mV scale. This error can be adjusted inside the software algorithm. Errors introduced by the temperature sensors, current sensor and voltage transformers are ignored. Future work is under process to extend the system to utilize the server and a database system. This database system will periodically store all the parameters from the transformers and later this data can be used for useful analysis. Also, error correction, offset and gain adjustment circuits can be added to the signal conditioning circuit to minimize the error and enhance the accuracy.

## V. SIMULATION RESULTS

The simulation results using the IOT Adafruit web application below. The simulation result shows the transformer voltages, currents, humidity, temperature [5], and oil level.



Fig.5: Adafruit IOT Dashboard

In this guide, we are going to build an Internet of Things dashboard using the Adafruit IO service. We will see that using Adafruit IO [6] makes the process so much easier, as it will allow us to easily send data to the cloud from an Arduino board, and also easily building an Internet of Things dashboard just by dragging & dropping some elements.

## VI. CONCLUSION

An IOT based transformer monitoring system for power transformer was designed, implemented and tested. It is quite useful as compared to manual monitoring and also it is reliable as it is not possible to monitor always the oil level, oil temperature rise, ambient temperature rise, load current manually. A server module can be added to this system to periodically receive and store transformer parameters information about all the power transformers in a database



ISSN (Print) : 2320 – 3765  
ISSN (Online): 2278 – 8875

# International Journal of Advanced Research in Electrical, Electronics and Instrumentation Engineering

(A High Impact Factor, Monthly, Peer Reviewed Journal)

Website: [www.ijareeie.com](http://www.ijareeie.com)

Vol. 9, Issue 3, March 2020

application. After receiving message on any abnormality we can take immediate action to prevent any catastrophic failures of power transformers. We need not

have to check all power transformers and corresponding phase currents and voltages and thus we can recover the system in less time and faults before any uncertain failures thus resulting in significant cost saving as well as improving system reliability.

## REFERENCES

- [1] S.HarshaVardhan, Ch.Akhil and G.Sona, (2018),“An Automated SMS-Update System Through Automated SMS-Update System Using Raspberry Pi”, International Journal of Mechanical Engineering and Technology (IJMET)Volume 9, Issue 1, January 2018, pp. 118–124, Article ID: IJMET\_09\_01\_ISSN Print: 0976-6340 and ISSN Online: 0976-6359.
- [2]C.Nagarajan and M.Madheswaran - ‘Stability Analysis of Series Parallel Resonant Converter with Fuzzy Logic Controller Using State Space Techniques’- Electric Power Components and Systems, Vol.39 (8), pp.780-793, May 2011
- [3] Radha R. Mahalle, S. S. Thorat , (2018),“Smart Blood Bank Based On Iot:Review” , nternational Research Journal of Engineering and Technology (IRJET)e-ISSN: 2395-0056 Volume: 05 Issue: 01 | Jan-2018 www.irjet.net p-ISSN:2395-0072.
- [4] T.Gayatri Devi, G.Vijay Kumar, (2017),“Automated Blood Donating And Managing System Using Raspberry Pi B+” SSRG International Journal of Computer Trends and Technology(IJCTT)-Issue–April2017ISSN:2231-2803,http://www.ijctjournal.org Page 33.
- [5] Danny J. Pereira, HarshadaSutar, NehaRamane, PriyankaTanpure, SonaliChavan, (2016),“Blood At One Touch” ,IJSRSET | Volume 2 | Issue 2 | Print ISSN:2395-1990|OnlineISSN:2394-409Themed Section: Engineering and Technology795.
- [6] M. GeethaPratyusha , P.V.V.N.D.P. Sunil , K. Tejaswi , P. Kanakaraja , Y.RamyaSree ,(2016),“Raspberry-Pi Based Embedded Blood Donating Application”International Journal of Innovative Research in Science,Engineering and Technology (An ISO 3297: 2007 Certified Organization) Vol. 5, Issue 4, April 2016, ISSN(Online) : 2319-8753 ISSN (Print) : 2347-6710.
- [7]Miss. Pooja A. Taywade, (2016),“A Review On Implementation Of Sms (Short Messaging Service) Based Automated Blood Bank Using Raspberry Pi For Rural Areas”, International Journal of Scientific & Engineering Research, Volume 7, Issue 2, February-2016 ISSN 2229-5518.
- [8]E Geetha, C Nagarajan, “Induction Motor Fault Detection and Classification Using Current Signature Analysis Technique”, 2018 Conference on Emerging Devices and Smart Systems (ICEDSS), 2<sup>nd</sup> and 3<sup>rd</sup> March 2018, organized by mahendra Engineering College, Mallasamudram, PP. 48-52,2018
- [9] Prof. Snigdha, VarshaAnabhavane, Pratikshalokhande, Siddhi Kasar, Pranita More, (2015),”Android Blood Bank”International Journal of Advanced Research in Computer and Communication Engineering Vol. 5, Issue 4, April 2016 Copyright to IJARCCCE DOI 10.17148/IJARCCCE.2016.54150 612 ISSN (Online) 2278-1021 ISSN (Print) 2319 5940.
- [10] K M Akkas Ali, IsratJahan, Md. Ariful Islam, Md. Shafa-at Parvez, (2015) “Blood Donation Management System”, American Journal of Engineering Research (AJER)e-ISSN: 2320-0847 p-ISSN : 2320-0936Volume-4, Issue-6, pp-123-136.
- [11]C. Nagarajan, M.Madheswaran and D.Ramasubramanian- ‘Development of DSP based Robust Control Method for General Resonant Converter Topologies using Transfer Function Model’- Acta Electrotechnica et Informatica Journal , Vol.13 (2), pp.18-31, April-June.2013
- [12] BalaSenthilMuruganL, Anitha Julian, (2015),“Design And Implementation Of Automated Blood Bank Using Embedded Systems”, IEEE Sponsored 2nd International Conference on Innovations in Information, Embedded and Communication systems (ICIIECS)978-1-4-4799-6818-3/15/\$31.00 © 2015 IEEE.
- [13] P. Priya, V. Saranya, S. Shabana, KavithaSubramani ,(2014),“The Optimization Of Blood Donor Information And Management System By Technopedia” ,InternationalJournalofInnovativeResearchinScience,EngineeringandTechnology, An ISO 3297: 2007 Certified Organization, Volume 3, Special Issue 1, February 2014ISSN (Online) : 2319– 8753ISSN (Print) : 2347 – 6710.