



Smart Helmet with Sensors Using Arduino

Suvarna S Patil¹, Shravani Kolor², Seresha VB³, AP Sushma⁴

Assistant Professor, Dept. of ECE, RYM Engineering College, Ballari, Karnataka, India¹

UG Student, Dept. of ECE, RYM Engineering College, Ballari, Karnataka, India²

UG Student, Dept. of ECE, RYM Engineering College, Ballari, Karnataka, India³

UG Student, Dept. of ECE, RYM Engineering College, Ballari, Karnataka, India⁴

ABSTRACT: Currently, accidents are a serious problem for everyone. Accidents are increasing day by day, so efforts are made to avoid them to minimize their consequences. We live in a world where the rules of the road have no importance for people and they are regularly violated. In addition, its human nature to resist what is imposed on them. Thus, using a different perspective, we provide safety with luxurious and intelligent features using a smart helmet. Smart Helmet is an AVR series microcontroller based project. It is a helmet with some smart features to improve driving experience and to make drive safer. This smart helmet has three main features and each feature has its own purpose like the purpose of first feature is to encourage or force rider to wear helmet, similarly the purpose of second feature is to prevent rider to drink and drive, and third feature is to save lives as many as possible when accidents occur by sending information. Two modules one on the helmet and bike each will work in synchronization, to ensure that the biker is wearing the helmet. A radio frequency module is responsible for the wireless communication between the helmet and the bike circuit. The ALCHO-LOCK function is used to prevent drink and drive scenarios Accelerometer detects accidents, and this is extended by employing GSM module in our circuit, which is designed to automatically send one message to one personal contact and one concerned authority that the person has been into an accident and a fog sensor for increasing visibility in case of fog or smog are also used. The project is expected to improve safety and reduce accidents, especially fatal to the motorcyclist.

KEYWORDS:RF module, accelerometer, microcontroller, arduino, sensors, motorcyclis

I.INTRODUCTION

It is a well-known fact that young generation prefers bikes and motorcycle over four wheelers. A survey indicates that more than 70% of the riders avoid wearing helmet without any specific reason. A traffic accident is defined as any vehicle accident occurring on roads. Two wheeler accidents are increasing day by day and lead to loss of many lives. In many accidents that occur around us, there is a huge loss of life. According to a survey, about "7500" people die on roads per year that occur due to bike accidents. Due to lack of experience or focus and violation of traffic rules, result in severe accidents. So the idea of developing our project comes from our social responsibility towards society to help society in reducing the occurrence of accidents as much as possible. There are various reasons for accidents such as not having adequate ability to drive, defective two wheelers, rash driving, "drinking and driving", etc. But the main reason was the absence of helmet on that person which leads to immediate death due to brain damage. Therefore, it is important that there should be a facility to minimize the after effects of these accidents.

However the main goal of our work is to make it mandatory for the rider to wear a helmet during the ride meanwhile providing solutions to other major issues for accidents. Therefore, this sense of moral responsibility towards society, laid the foundation for our "Smart Helmet" project.

Smart helmet focuses on three major objectives which are helpful in our day to day life. At first and foremost one is the ignition of the bike will not start unless and until we wear a helmet. Secondly alcoholic driving is not possible when wore a smart helmet. If the rider is alcoholic, the bike will not start. Third application is accident detection. If a person meets with an accident and no one is there to help him, or when he is in a remote areas, in such situations we can inform his family members and hospital with help of this smart helmet using technology. Various technologies are now available for bike rider safety. Wireless communication between bike to helmet and bike to traffic signal and speed breaker where the system will be comprised of a helmet module including stereo speakers and microphone, and a bike mounted base unit.

The system will make use of different wireless communication protocols including zigbee and another radio frequency protocols. When the dose not know where the speed breakers are, by using RF technology they will find out where the speed breakers are there. Smart Helmet with Sensors for Accident Prevention, the microcontroller used in the system is Peripheral Interface Controller (PIC).



Force Sensing Resistance (FSR) and the speed sensor are used as sensors to operate this system. Signal transmission between the two circuits is using a radio frequency concept. 315 MHz Radio Frequency Module is used since the range between the circuits is short. A Solar Powered Smart Helmet with Multi features has features like Engine control system with the smart, in built Bluetooth system, accident alert system, emergency alert switch (it gives the emergency message to police or family members) and cell phone charging with the solar power.



Fig 1: Road accident

II.SYSTEM MODEL AND ASSUMPTIONS

An important part of the accidents happens because the individual was either not wearing a helmet, or the accident was not revealed in time, or the person couldn't be safe in view of the late induction to an emergency clinic, or on the grounds that the person was riding while smashed.

Sensors distributed, Wi-Fi empowered processor, and computing foundations are used for building the structure. The accident discovery is finished utilizing the accelerometer and the accident warning is finished utilizing the customer and server-based framework where the microcontroller is the customer and the server is an online administration.

At the point when an accident happens, the related subtleties are sent to the crisis contacts by using a cloud-based administration. Most of the attention today in helmet innovation is on things like adding an MP3 player or wireless phone or even a flash light on it. But none of these features provide additional safety for the rider and are just meant for amusement.

III. SYSTEM OBJECTIVES

This system is based on new technology, its main purpose is to detect an accident and alert to the control room/ambulance/home, so the victim can find some help. It can detect accidents the intensity of the accident without any visual contact from control room. If this system is inserted in every helmet then it is easy to understand how many bikes are involved in a particular accident and how intense is it. So that the help from control room will be according to the control room. The present board designed has both vehicle tracking and accident alert systems, which make it more valuable and useful. This board alerts us from theft and on accident detection also. This device detects fire accidents also by placing fire detector in one of the interrupt pins.

- To design system that can improve bike rider safety.
- To design system that reduces the number of accident due to the drink and drive.
- To design system that ensure that the rider has worn helmet.
- To design system that reduces the loss of life due to late arrival of the ambulance.

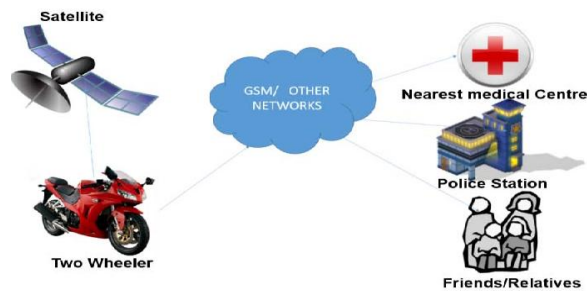

Fig 2: system objectives

IV. PROPOSED SYSTEM

a) Helmet unit

The helmet unit comprises of an alcohol sensor, helmet on detection circuit, a fog sensor, GSM and GPS module, LCD display, microcontroller ATmega328-PU, accelerometer for accident detection and a RF module. The sensors installed in the helmet provide analog output. This output is fed to a comparator that acts as an ADC. The output signal from the comparator and the sensor lock is encoded in binary signals, which are transmitted via the RF transmitter. RF Module consists of a transmitter with a 5 meter range. It is used to transmit control signals to the bike module for implementation.

1) ATmega 328 pin

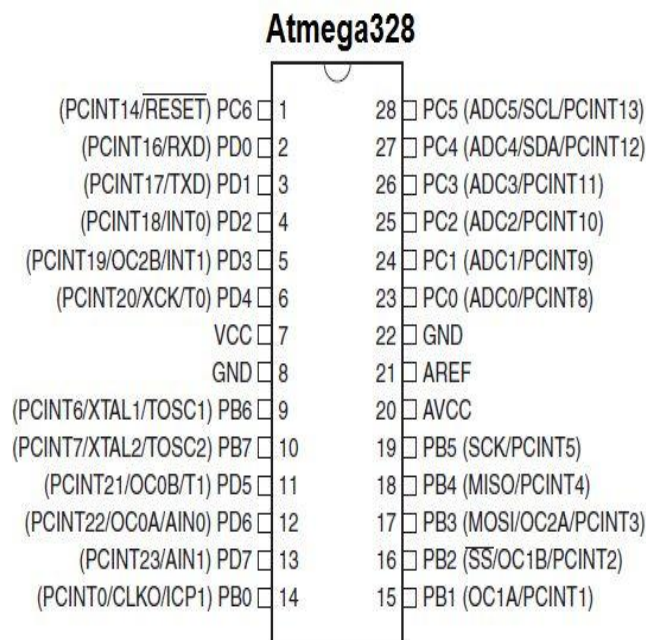

Fig 3: ATmega 328 pin configuration

2) Alcohol sensor

The Grove - Gas Sensor (MQ2) module is useful for gas leakage detecting (in home and industry). It can detect H2, LPG, CH4, CO, Alcohol, Smoke, propane. Based on its fast response time. Measurements can be taken as soon as possible. Also the sensitivity can be adjusted by the potentiometer.

Features

- Wide detecting scope
- Stable and long life
- Fast response and High sensitivity.



Fig 4: alcohol sensor

3) Piezo electric sensor

A piezoelectric sensor is a device that uses the piezoelectric effect to measure changes in pressure, acceleration, temperature, strain, or force by converting them to an electrical charge. There are various types of piezoelectric materials. Examples of piezoelectric materials are natural available single crystal quartz, bone etc. Artificially manufactured like PZT ceramic etc

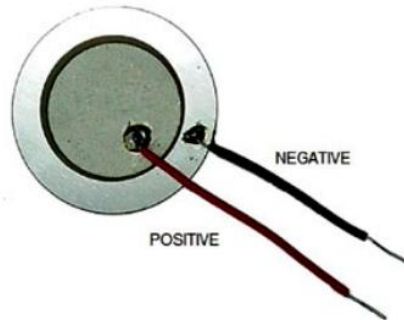

Fig 5: piezo electric sensor

4) GPS module

GPS module sends the data related to tracking position in real time, and it sends so many data in NMEA format (see the screenshot below). NMEA format consists several sentences, in which we only need one sentence. This sentence starts from **\$GPGGA** and contains the coordinates, time and other useful information. This **GPGGA** is referred to **Global Positioning System Fix Data**.

5) GSM module

The SIM900 is a complete Quad-band GSM/GPRS Module which can be embedded easily used by customer or hobbyist. SIM900 GSM Module provides an industry-standard interface. SIM900 delivers GSM/GPRS 850/900/1800/1900MHz performance for voice, SMS, Data with low power consumption. AT means ATTENTION. This command is used to control GSM module. There are some commands for calling and messaging that we have used in many of our previous GSM projects with Arduino. For testing GSM Module we used AT command. After receiving AT Command GSM Module respond with OK. It means GSM module is working fine.



Fig 6: AT command



6) Block diagram

Block diagram consist of two units Helmet unit and Bike unit. Helmet unit consist of Arduino Uno, Flex sensor, MQ-3 sensor, ADXL-335 Accelerometer, RF transmitter, Buzzer, GSM modem, GPS modem, LCD display, Power supply. Bike unit consist of RF receiver, Relay, Ignition system, Power supply unit. The whole system is controlled by arduino Uno unit. Different functions are controlled by using sensors. The arduino UNO is placed in the helmet unit. The inputs from different sensors are given to arduino unit and which is analyzed by the arduino and given to the bike unit by RF transmission. The power supply is given to the bike unit.

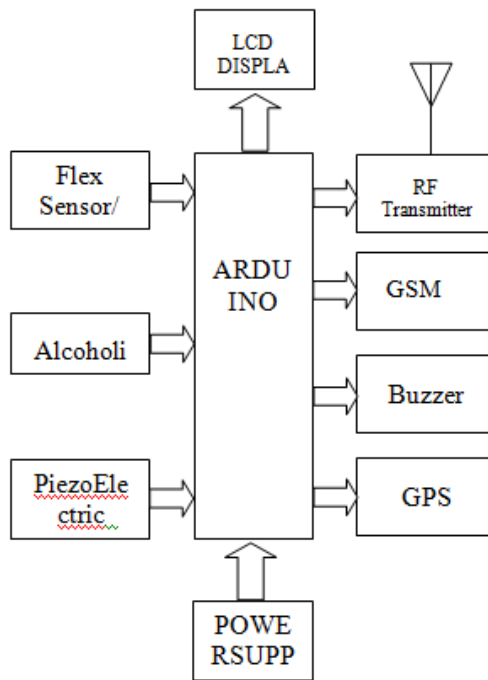

Fig 7: block diagram of helmet part

b) Bike part

This section consists of a receiving part and a control signal. The receiver section is located on a bike; It consists of radio frequency receiver, decoder, microcontroller, LED as an indicator, DC motor. The RF receiver receives the encoded binary data transmitted by the RF transmitter and provides it to the decoder. The decoder decodes the incoming digital data and provides four bits in the MCU, only if the address bit of the encoder and the decoder match. This is done to ensure the safety and security of the system. Thus matching of encoder and decoder increases the security and integrity of the system. The MCU controls the DC motor upon receiving data. If the sensor detects that the rider is wearing the helmet, then the engine is turned on and also if the MQ6 sensor detects alcohol, the module installed on the bike turns off the engine to avoid any accidents and so that the drunken person takes appropriate measures to reach his destination.

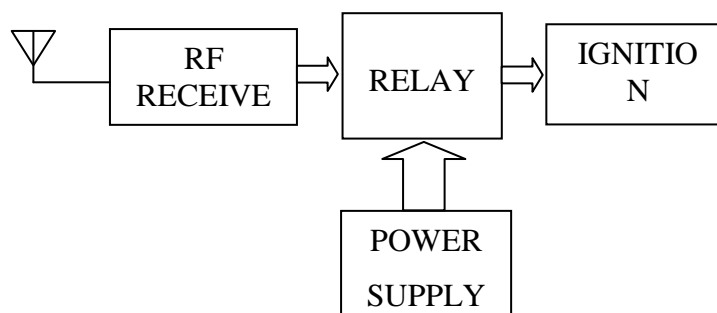

Fig 8: block diagram of bike part



V. PRINCIPLE OF OPERATION

The proposed system works with simultaneous working of the transmitter and receiver section. A magnetic chip connected with the helmet detects if the rider is wearing the helmet or not. The chip sends out an analog signal, signalling the system that helmet is detected and the rider is wearing it. This is determined by a high output received from the chip. A low output is generated when the clip is not connected making the system to turn off the bike.

Another scheme uses a gas sensor (MQ-6), which can detect the presence of alcohol. The surface of the sensor is sensitive to various alcohol concentrations. It detects alcohol in the exhaled air of the rider. The value of the resistance decreases which leads to a change in the voltage. This changed voltage is fed to the comparator, which compares the voltage with the predetermined value, and changes according to the alcohol concentration below the level of illegal consumption. If the sensor voltage exceeds the voltage at the output of the present comparator, the microcontroller performs the appropriate action.

Speed limit sensing element contains a turbine. The moving bike revolves the motor on the turbine which tells us about the speed of the bike and if a predetermined limit is exceeded a buzzer goes off warning the rider of speeding.

Another feature uses a LDR in order to avoid incidents due to low visibility in fog. Fog sensing unit consists of an LDR i.e. Light Dependent Register which detects the light coming from LED. If the presence of fog inhibits the light from the LED to reach the LDR, the fog sensor sounds an alarm, to counter this we employ a bright blinking LED that makes the presence of the rider much more visible.

Accident detection circuitry is made up of an accelerometer and some resistors. The accelerometer checks the tilt of the helmet to determine the occurrence of an accident. If the tilt of the helmet is more than a preset value, which is set in accordance with case of an accident, free-fall sensing concludes that the rider has met with an accident. During an accident the accelerometer discharges a voltage which is read by the unit sending a signal to the bike module to turn off the engine and it sends message to one personal contact and one concerned authority that an accident has occurred.

GSM modem communicates with microcontroller through USART (Universal Synchronous Asynchronous Receiver Transmitter) and microcontroller gives command to GSM modem known as AT (Attention) commands to send message to one personal contact and one concerned authority.

VI. RESULTS

All the components are assembled and tested successfully. The circuit is designed in such a manner that bike does not start until and unless rider wears the helmet. Also the bike won't start if the rider is drunk, this helmet alarms the rider if he crosses a certain speed limit by buzzing an alarm. If an accident occurs the engine automatically shuts off to avoid further injuries.

VII. CONCLUSION

The smart helmet developed is a smart and reliable piece of technology that is cheap to develop and operate and yet not compromise on safety. Additionally, it offers several advantages over the existing methods of accident detection and notification systems that rely heavily on the data collected from cellular devices of the drivers. Also, most of the systems that are available in the automobile market are designed for only four-wheeled vehicles.

This paper presents vehicle accident detection and alert system with SMS to the user defined mobile numbers. The GPS tracking and GSM alert based algorithm is designed with Arduino MCU in embedded system domain. The proposed Vehicle accident detection system can track geographical information automatically and sends an alert SMS regarding accident. The proposed method will be highly beneficial for the automotive industry

REFERENCES

- [1] Nimisha Chaturvedi, Pallika Srivastava. "Automatic Vehicle Accident Detection and messaging System Using GSM and GPS Modem", Volume: 05 Issue: 03 |Mar-2018 C.Prabha, R.Sunitha, R.Anitha.
- [2] Vikram Singh Kushwaha, Deepa Yadav, Abuyeed Topinkatti, Amrita Kumari . "Car Accident Detection System using GPS and GSM", Volume 2, Issue 1(Jan-Feb 2015), PP12
- [3] "Automatic Vehicle Accident Detection and Messaging System Using GSM and GPS Modem", Vol. 3, Issue 7, July 2014 Hoang Dat Pham, MichealDrieberg, Chi Cuong Nguyen
- [4] "Development of vehicle tracking system using GPS and GSM modem", Conference: 2013 IEEE Conference on Open Systems (ICOS) Lih-Jen Kau, Member, IEEE, and Chih-Sheng Chen
- [5] "A Smart Phone-Based Pockert Fall Accident Detection, Positioning and Rescue System", Dec 2013.



- [6] G. Acampora, D. J. Cook, P. Rashidi, A. V. Vasilakos, “A Survey on Ambient Intelligence in Healthcare”, Proceedings of the IEEE, pp. 2470-2494, Vol. 101, No. 12, Dec. 2013.
- [7] J. White, C. Thompson, H. Turner, B. Dougherty, and D. C. Schmidt, “WreckWatch: Automatic Traffic Accident Detection and Notification with Smartphones,” Mob. Netw. Appl., vol. 16, no. 3, pp. 285–303, Jun. 2011.
- [8] Yilin Zhao, "Mobile phone location determination and its impact on intelligent transportation systems", IEEE Trans. Intell. Transport. Syst., vol. 1, no. 1, pp. 55-64, 2000.
- [9] M. Fogue, P. Garrido, F. Martinez, J.-C. Cano, C. Calafate, and P. Manzoni, “Automatic Accident Detection: Assistance through Communication Technologies and Vehicles,” IEEE Veh. Technol. Mag., vol. 7, no. 3, pp. 90–100, Sep. 2012.