



Design and Construction of a Quadcopter with Payload for Pipeline Inspection and Surveillance

¹BO Omijeh, ²VM Oden, ²KJ Joseph, ³JA Erameh

^{1,2}Department of Electronic and Computer Engineering, University of Port Harcourt, Rivers, Nigeria

³Department of Biochemistry, University of Port Harcourt, Rivers State, Nigeria

ABSTRACT: The aim of this study was to create a sustainable and flexible platform for an Unmanned Aerial Vehicle (UAV) capable of carrying out inspection in real-time on a pipeline facility and perform surveillance actions using a quadcopter design profile. In other to achieve this, special components were used and certain equations governing the choice of components were considered. The design analysis of this project was carried out in two stages (Hardware and Software), with each stage subdivided further into smaller stages (Requirements, alternatives, decision criteria, decision, and implementation details). To safely fly the quadcopter, various tests were carried out on the individual components and the quadcopter at whole to ensure everything was functioning properly before flight. Two test stages were carried out on the quadcopter, these tests are Unit tests and Flight tests. After concluding the pre-flight and post flight tests, results were gotten and tables were created. The graphs in section IV show the results gotten. The results obtained in this study showed that the system was capable of attaining autonomous flight at a height of 20 meters and a range of 30 feet.

KEYWORDS: Unmanned Aerial Vehicle (UVA); Auto Pilot Module (APM); Radio Control(RC); Transmitter (T_x); Receiver (Rx); Pulse Code Modulation (PCM); Pid-Proportional Integral Derivative (PID); Global Positioning System (GPS); Return To Landing (RTL); Personal Computer (PC)

I. INTRODUCTION

Radio controlled helicopters and planes are highly valued for their ability to remotely fly wide areas without the risks of their traditional manned aircraft. They have high potential for use in remote-sensing applications; surveillance; scientific study and research. Research and development of these devices are getting high encouragement day-by-day. Real life situations where they have found operations are the US coast guard maritime search and rescue mission and the British Petroleum (BP) pipeline inspection in Alaska. Here; these devices are equipped with infra-red cameras that relay video and image signals back to a base station; not very far away from the area of operation; this intelligent signals are further processed with software applications to identify targets and hotspot areas.

In the center of all these researches and developments of UAVs is the quadcopter or quad rotor aircraft; also known as Multicopter. It has been the major focus of active research in recent years compared to terrestrial mobile robots that are often limited to kinematics. Quadcopters require dynamics in order to account for gravity effect and aerodynamics forces.

The use of helicopters to transport personnel to non-accessible areas for inspection or surveillance purposes is fast becoming both expensive and dangerous due to the nature of the area in terms of geographical land type (swampy; deep water; etc.) and volatility of the locality. The helicopter in this case is an easy target for nefarious attacks hence the need for a technology that can eliminate the risk of losing personnel and investments while still achieving maximum results. The quadcopter can achieve Vertical Take-Off and Landing (VTOL) in a more stable condition; unlike the helicopter. It is not affected by torque issues that a helicopter experiences due to the tail rotor. It also has advantage over conventional helicopter in that its mechanical design is simpler.



International Journal of Advanced Research in Electrical, Electronics and Instrumentation Engineering

(A High Impact Factor, Monthly, Peer Reviewed Journal)

Website: www.ijareeie.com

Vol. 6, Issue 9, September 2017

The aims and objectives of this project are;

1. To design a quadcopter that can be controlled wirelessly by a radio control transmitter and receiver.
2. To equip the quadcopter with a camera payload that can capture video images wirelessly and interface in real-time with a personal computer (PC).
3. To test the performance of the design by tethered and untethered flight tests.

II. HISTORY

A few authors have been able to achieve reasonable milestones on the same system for example; some achieved only tethered flight because their quadcopters could not maintain stable positions when flying while some designed semi-autonomous quadcopters capable of self-sustained flight via wireless communications while utilizing two different microcontrollers [1-2] attempted to design a quadcopter to autonomously stabilize itself as his final year project; however it was just an attempt [3]. created a sustainable and flexible platform for an Unmanned Aerial Vehicle (UAV) using a quadcopter design profile [4]. designed but didn't implement an autonomous quadcopter that integrated an android smartphone; an Arduino MCU and several ultrasonic sensors to independently explore and map an unknown area. In 2015; The Mathworks; Inc. attempted a matlab simulation of the same system. Yet another author built a miniaturized radio controlled quadcopter with cameras attached to it in 2015; designed to be controllable by smartphones or tablet devices; but could only achieve 5 minutes flight time. In July 2015; a video was posted on YouTube of an airborne quadcopter with a handheld pistol as its payload. Designed by an anonymous individual; it sparked lots of regulatory concerns though it was lauded as an ingenious attempt at the same work and hence increased the design capabilities of the UAV (quadcopter type) design. Though a lot of students and companies have attempted same project; only a few have successfully designed and constructed a quadcopter.

III. DESIGN METHODOLOGY AND ANALYSIS

The design analysis of this project was carried out in two stages (Hardware and Software); with each stage subdivided further into smaller stages (Requirements; alternatives; decision criteria; decision; and implementation details). The next chapter will discuss the unit tests on each of the components. The following are the constraints involved in the implementation of this project;

1. The quadcopter can only operate in a sunny or dry condition/weather.
2. The quadcopter can operate only at a range of 20 meters from eye sight and 30 feet away from the operator.

International Journal of Advanced Research in Electrical, Electronics and Instrumentation Engineering

(A High Impact Factor, Monthly, Peer Reviewed Journal)

Website: www.ijareeie.com

Vol. 6, Issue 9, September 2017

3. The quadcopter is controlled by an Arduino based microcontroller and a radio controller.
4. The quadcopter has an endurance of not more than 10 minutes.

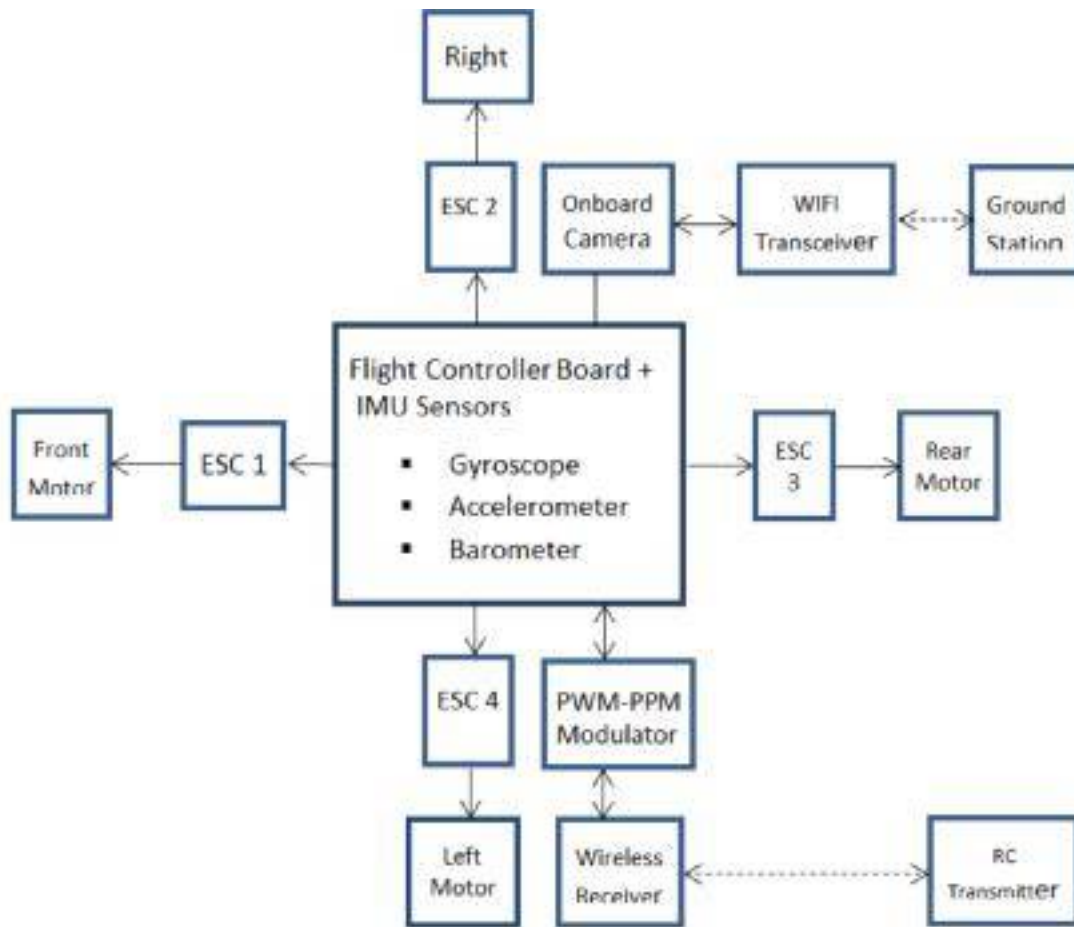

Figure1: Block diagram of the Quadcopter.

The Figure 1 above shows the block diagram of the system. The project is divided into four main parts which are the input unit; control unit; output unit and the power supply and distribution unit which are explained further below:

3.1. Input Unit

The input unit comprises of an RC transmitter and receiver. The RC transmitter is used to send controls to the flight controller on the quadcopter. It is also used as a means for manual flight.

a. Hardware Requirements

The RC transmitter should be compatible with the RC receiver on the quadcopter or come with a receiver that can be easily implemented on the quadcopter. It should have the correct control features of throttle; pitch; yaw; and roll to control the quadcopter [4-6].



International Journal of Advanced Research in Electrical, Electronics and Instrumentation Engineering

(A High Impact Factor, Monthly, Peer Reviewed Journal)

Website: www.ijareeie.com

Vol. 6, Issue 9, September 2017

b. Alternatives

An RC transmitter module and an RC receiver are used to send RC communication to the quadcopter. The first option explored and tested was the Spektrum 7X transmitter. The second option considered was the FlySky FS-CT6B.

c. Decision Criteria

Cost; delivery-time; and ease of modification were considered in deciding which RC transmitter to use.

d. Decision

A Spektrum 7X transmitter was initially used due to its immediate availability to the team. However; after two instances of unsolvable defects; we decided to change that decision. The Spektrum 7X transmitter though cheaper; had a delivery time of about two to four weeks while the Futaba 6EX-PCM transmitter even though more expensive; had a delivery time of five to seven days. The delivery time was more important than cost at the time of this decision; as well as the fear of another Spektrum transmitter being defective. Because of this; we chose the Futaba 6EX-PCM transmitter.

e. Implementation

The team incorporated the new transmitter's receiver into the quadcopter and the transmitter was connected to the RC interface module. Crystal oscillators are used in setting the transmitting and receiving frequencies of the RC to 72.870MHz transmitting and 72MHz receiving. This locks the transmitter to the receiver to avoid misalignment.

3.2. Control Unit

For a design project such as this; specialized microcontrollers that are designed for flight should be used except proper knowledge on how to interface several sensors and modules to a clean microprocessor is gained. Hence; a flight controller could be said to be a microcontroller unit used to interpret RC controls; provide telemetry data to a base station; as well as provide dynamic control feedback to keep the quadcopter stable during flight.

a. Hardware Requirements

The flight controller should support GPS navigation and should be programmable with code that can be easily edited by the user. That is; the team should have access to the flight controller code and modify it per project needs. In addition; it will aid in satisfying the following requirements:

1. The system should fly as far as 100 meters (328 ft.) from the operator without losing communication. 100 meters (328 ft.) is considered a good starting place for the project [8].
2. The system should withstand wind speeds up to 27 km/hr [9,10].
3. The system should weigh no more than 5 kg (11.1 lbs.) which is part of the design goal.

b. Alternatives

For this project; we investigated using; ArduPilot Mega (APM) 2.6; AutoQuad 6; MultiWii Plus; MultiWii Lite and Aero Quad 32 flight controllers. The team did not consider all flight controllers because there are so many different types; so these five were selected with their features laid out in Table 1.



International Journal of Advanced Research in Electrical, Electronics and Instrumentation Engineering

(A High Impact Factor, Monthly, Peer Reviewed Journal)

Website: www.ijareeie.com

Vol. 6, Issue 9, September 2017

Controller	Gyroscope	Barometer	Magnetometer	Experience
APM 2.637	MPU6000	MS5611	HMC5883L	Yes
AutoQuad 638	IDG500/ ISZ500	MP3H6115A	HMC6042/ HMC1041Z	None
MultiWii Plus40	ITG3205	BMP085	HMC5883L	Yes
MultiWii Lite39	ITG3205	None	None	None
AeroQuad3236	MPU6000	MS5611	HMC5983-TR	None

Table 1: Flight controller alternatives.

c. Decision Criteria

We evaluated the flight controllers based on their sensors included; waypoint capabilities; and previous experience with the controller. Weight difference was negligible (~5 g) so weight was not used as a decision criteria. The firmware that the flight controller runs is important; but in order to test this we would have needed to individually purchase and test all of the alternatives; which would have surpassed our budget and time constraints.

d. Decision

We had to hence use an APM 2.6 flight controller for the design. This therefore gave the team experience using an APM flight controller. Over interim; the team had a chance to use the MW Plus flight controller. This controller has been used for other prototypes of UAVs; and it proved equally effective in providing a stable flight. Both flight controllers also provided similar flight modes such as altitude-hold; heading-hold; and various stability and GPS flight modes. MW also provided better accessibility to the source code for the flight control software; giving the team better access to make changes to that software. This choice was made to mitigate start-up time if a different flight controller was chosen. Because the APM 2.6 proved more effective than the MW plus even though it was more expensive we decided to go with the APM 2.6 flight controller. The test of this flight controller is highlighted in section IV of this work.

e. Software alternatives

This is the set of instructions that govern the movement of the quadcopter and handles all of the dynamic feedback control loops. The flight controller software runs on the flight control board. The programming language used in the programming of the APM 2.6 flight controller is the C-programming language (C++ more precisely). The choice of this language; was due to the following factors (Kothari; 2012).

1. Robust nature of the C++ language
2. Stronger Type Checking
3. You can use class libraries to provide robust new data types which can be made exceptionally easy to use.

International Journal of Advanced Research in Electrical, Electronics and Instrumentation Engineering

(A High Impact Factor, Monthly, Peer Reviewed Journal)

Website: www.ijareeie.com

Vol. 6, Issue 9, September 2017

4. C++ Compiles most ANSI C code directly and can call compiled directly; so you don't even have to learn anything new at all.

C. code

The software used on the flight controller is most directly related to the hardware itself. Other flight controllers come with their own custom flight software. The MW board has two main software options: MultiWii and MegaPirate. Both options offer similar flight modes and overall functionality

f. Decision

We choose to use the C++ programming language with a few python and embedded c programming codes as subroutines to enable a more robust platform for the quadcopter to receive a wide variety of inputs from the different hardware options present. Below is the program architecture for the flight control (Figure 2).

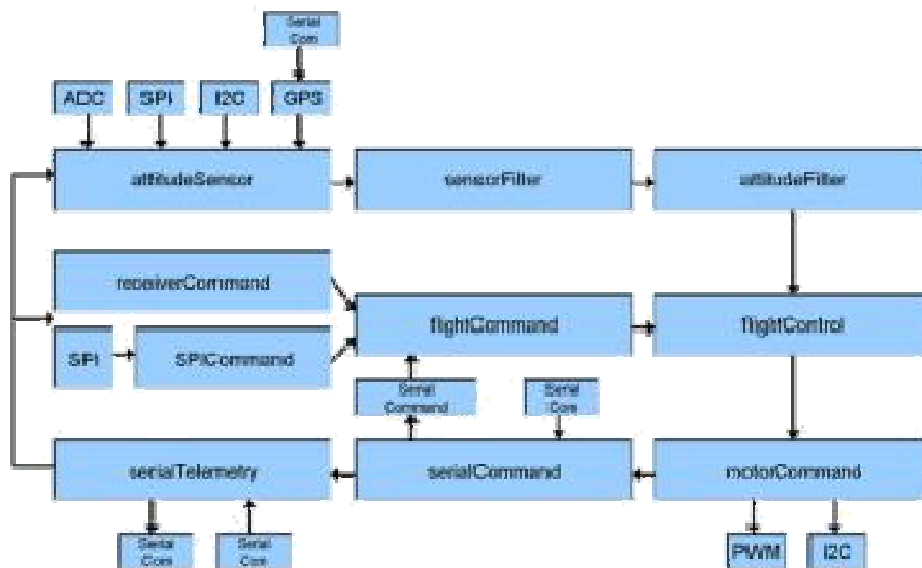

Figure 2: Program architecture.

3.3. Output Unit

The output unit is made up of the electronic speed controllers and the brushless motors. Since the output on the motors increases and decreases per user choice of motion or movement; an electronic speed controller helps to vary the speed allowing the various user inputs. These components are explained below:

- Electronic Speed Controller

Electronic Speed Controllers regulate power; and thus speed; for each motor.



International Journal of Advanced Research in Electrical, Electronics and Instrumentation Engineering

(A High Impact Factor, Monthly, Peer Reviewed Journal)

Website: www.ijareeie.com

Vol. 6, Issue 9, September 2017

a. Requirements

The ESC's should provide enough current to power the motors effectively. This means the ESC's must have a higher current rating than the motors they control. In addition; the ESC's will help satisfy the following requirements:

1. Long flight time as per design goal.
2. The quadcopter should operate fully in a temperature range of 0 to 70 degrees Celsius (32 to 158 degrees Fahrenheit) [10, 11].
3. The system should fly at all humidity levels [12, 13]

b. Alternatives

ESCs can be found with different current values and are made by several manufacturers. For this project; we first considered 3DRobotics as a component vendor because of their short delivery time on components. 3DRobotics only sells one ESC; a 20A ESC with a battery eliminator circuit (BEC) output of 5V and 2A. The other ESC's that could be used include Turnigy Plush 25A ESCs with a BEC output of 5V and 2A; from HobbyKing.

c. Decision Criteria

The major criteria for ESCs are current output; cost; and compatibility with the selected motors. The ESCs also provide BEC capabilities; but this is discussed in the power distribution system in section 4. The ESCs also needed to be compatible with the voltage of the battery used in order to power the motors. The current output was a major criterion because the ESCs needed to provide at minimum the same current than the motor can draw (17 A for the motors selected).

d. Decision

Because of the amount of power needed and the unavailability of time to purchase a second ESC if the first set fail; we decided to use the Hobbyking 30A UBEC electronic speed controller as the Current rating allows for more power.

f. Implementation

Four ESCs were purchased; with each one being connected to a specific motor. These ESCs are powered from the power distribution board on the quadcopter and controlled from the flight controller. Below is the control diagram for the electronic speed controllers (Figure 3);

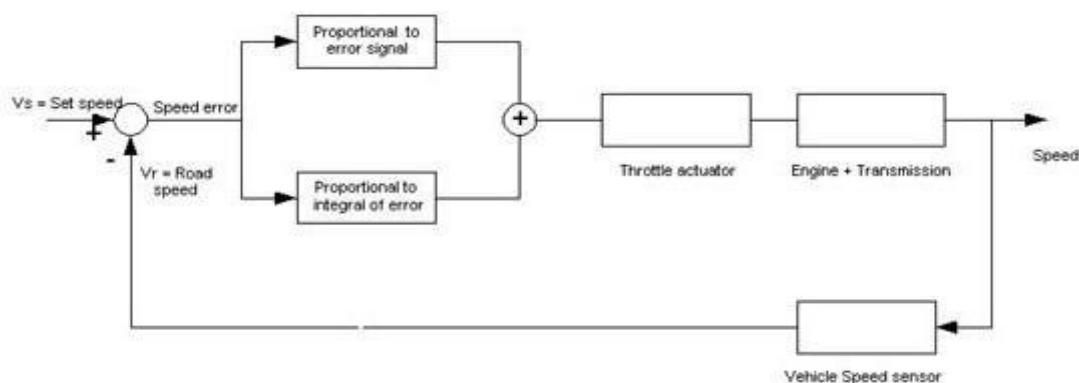

Figure 3: Program Architecture.



International Journal of Advanced Research in Electrical, Electronics and Instrumentation Engineering

(A High Impact Factor, Monthly, Peer Reviewed Journal)

Website: www.ijareeie.com

Vol. 6, Issue 9, September 2017

3.4. Motors

Four motors drive the propellers and provide thrust for the quadcopter.

a. Requirements

The motors should be powerful enough to spin the propellers; lift the quadcopter; and move the quadcopter at the required speed of 50 km/hr as per the design goal.

b. Decision Criteria

The motors chosen for the final design depended on weight; power (kV); current draw; and cost. The motors must have a maximum current draw lower than the ESC output rating. The shaft diameter is another factor as a thicker shaft makes for a more durable motor.

c. Decision

Ultimately; the decision was made to use the Turnigy Aerodrive D2830/11 1000kv brushless DC motors. Which provide 1000rpm speeds sufficient enough to lift the maximum 5kg load.

d. Implementation

Motors are mounted at the end of the quadcopter's four arms. They are each connected to an ESC with three wires. The order of wiring simply affects the direction that the motor turns. As such; two motors (opposite each other) are connected to spin counter-clockwise and two connected to spin clockwise.

3.5. Power Supply and distribution Unit

The power supply ultimately has to be a power source that can easily be carried by the lift of the motors and at same time provide enough burst and constant charge for the ESC's and motors while the power distribution unit should be able to deliver equal power to the four ESC's and motors without a lag which could be hazardous. The requirements are hence listed below:

IV. POWER SUPPLY

The battery provides stable voltage; high current power to all of the components on the quadcopter.

a. Requirements

The battery powering the quadcopter shall provide power for all on-board sensors and computers; as well as the ESCs and motors. The battery should provide power for the equipment for a minimum of ten minutes without overheating the system. The battery should also have protective circuitry to prevent overcharging and over-discharging which can cause batteries to catch fire and explode.

b. Alternatives

Lithium ion polymer (Li-Po) batteries are the standard power source for quadcopters so we limited our work to these batteries.

Lithium ion polymer batteries have power capacities ranging from 1000 mAh to 8000 mAh.



International Journal of Advanced Research in Electrical, Electronics and Instrumentation Engineering

(A High Impact Factor, Monthly, Peer Reviewed Journal)

Website: www.ijareeie.com

Vol. 6, Issue 9, September 2017

c. Decision Criteria

Cost was a portion of the decision for the battery chosen; but voltage output; discharge rate; capacity; and weight were major criteria as well. The battery needed to operate at a voltage of 11.1 V and have a discharge rate of at least 30 C. Batteries with larger capacities weigh more; creating a need for more power; and eventually diminishing the advantages of having a high capacity battery. Table 2 shows the capacity; weight; and charge time of several batteries that were considered. All of the listed batteries had the required voltage and discharge rates needed. Charge time was estimated with 5 A at 11.1 V (Clym; 2014).

Capacity (mAh)	Weight (g)	ChargeTime (min)
2450	218	29.4
3000	269	36.0
4000	358	45.8
5100	405	64.0
11,975*	1050*	143.7*

Table 2: Battery comparisons.

d. Production Decision

We would likely source a custom battery that better fits within the quadcopter packaging. Based on the described tests in the next section; average current draw for the system was 23.95 A. With a flight time of 30 minutes; the estimated battery size is calculated below:

$$23.95 \text{ A} \times (1000 \text{ h}) \times (30 \text{ min} / 60 \text{ min/h}) = 11,975 \text{ mAh}$$

This is a very large battery based off the current system specifications. The average cost per mAh was calculated to be \$0.0075. Based on this; a cost of about \$90 was predicted for this battery. The average grams per mAh was found to be 0.0877 grams/mAh. With this; the weight of the battery was estimated at 1.05 kg. Motor tests were performed with the 4000mAh battery; and the motors could lift an additional 0.9 kg.

This new battery would add an additional 636 g (0.636 kg) compared to the 5100mAh battery. While this extra weight is within the lifting ability of the motors; we would likely need to look for power consumption savings as well as reductions in weight in order to meet the flight time requirement of 10 minutes.

V. POWER DISTRIBUTION SYSTEM

The multiple electrical components on the quadcopter are powered by a power distribution system that is connected to the battery.

a. Requirements

The power distribution system shall provide adequate and stable current and voltage that is required for all components on the quadcopter. See Table 3.4 for these specific requirements. In addition; the system uses 23.95A on average.



International Journal of Advanced Research in Electrical, Electronics and Instrumentation Engineering

(A High Impact Factor, Monthly, Peer Reviewed Journal)

Website: www.ijareeie.com

Vol. 6, Issue 9, September 2017

	APM 2.6	Arduino MC	RC Receiver	ESC
Voltage (V)	4.5-5.5	7-12	4.5-6.5	12
Max Current (A)	<i>Not Available</i>	<i>Not Available</i>	<i>Not Available</i>	25

Table 3: Component power needs

5.1. Design Analysis

Whenever the word "flight" is viewed from the embedded system platform; a lot of parameters are considered by the system developer. This is because designing a flight system presents an interdisciplinary challenge and requires not just embedded system programming skills but a high level of precision in data interpretation and calibration. The above mentioned factors governed our choice and selection of materials and components. It is also worthy of note that the work employs advanced electronic components readily designed for specific purposes as regards flight operation. Thus; certain primary circuit diagrams (certain transistor-resistor connections) are only considered as passive circuitries and are discussed on a surface level.

The design requirements for the flight system development are the factors that influence the choice of components employed to design the flight system. These factors are discussed as follows;

5.1.1. Lift and Weight

In lift and weight analysis; our interest is actually to reduce weight thereby increasing the lifting ability of the flight system in design.

From weight to Rpm ratios; it is near certain that;

$$X \text{ kg (unknown weight)} = \frac{\text{Requird RPM}}{\text{Reference RPM}}$$

Also; from propeller length to weight ratios; we have that;

$$X \text{ cm (unknown propeller length)} = \frac{\quad}{h}$$

Thus; from ratio analysis; 1.0kg weight of quadcopter would demand;

- 2 pairs of 283 rpm brushless motors.
- 2 pairs of 8cm clockwise and counter clockwise length propellers.

The relationship governing the lift capabilities of this flight system is given below;

$$h = \frac{\quad}{\quad}$$

Where; W_q = Weight of quadcopter.

D_q = Rotation diameter of propeller blades.



International Journal of Advanced Research in Electrical, Electronics and Instrumentation Engineering

(A High Impact Factor, Monthly, Peer Reviewed Journal)

Website: www.ijareeie.com

Vol. 6, Issue 9, September 2017

D_{air} = Density of air. (Varies with altitude)

C_f = Lift coefficient = 1.

S = Speed in rpm

From the equation;

$$h \quad \text{-----}$$

Prospected weight of quadcopter = 2.5kg x 1000 = 2500g = W_q .

$$D_q^4 = (25\text{cm} \times 4) = 100\text{cm}.$$

$$D_{\text{air}} = (((D_{\text{air}} \times 24)/29.92) \times C_f) / 2.2$$

From the weight to rpm ratios; a prospected weight of 2.5Kg will require;

$$(2.5/1) \text{ kg} \times (\text{Reference rpm value/kg of weight})$$

Thus; 2.5kg x 283rpm = 707rpm.

Thus; 2 pairs of 707rpm brushless motors will lift a 2.5kg quadcopter

- How Lift; Weight And Rotational Motor Speed Analysis Influence Choice Of Components.

From the equation above; for the quadcopter to lift; the weight has to be as heavy as <7kg. Thus; all components selected were light weighted components. Carbon fiber propellers; plastic rubber support base and light-weight aluminum metal arms are employed on considering lift and weight analysis.

A weight of 2.5kg has been preset as maximum possible weight of the quadcopter. This figure is not a standard reference value for this design; and could be exceeded where required [14, 15].

VI. TESTS AND RESULTS

To safely fly the quadcopter; various tests were carried out on the individual components and the quadcopter at whole to ensure everything is functioning properly before being flight. Two test stages were carried out on the quadcopter; these tests were;

- Unit tests
- Flight tests.

6.1. Unit Tests

While the basic flight control of the APM 2.6 was tested simply by PID (proportional-integral-derivative) tuning and flying the quadcopter; there were a number of sensors that needed to be tested since they were used for the tracking algorithms. The barometer and compass on-board the flight controller were unit tested to ensure optimal performance. These tests and are discussed below.



International Journal of Advanced Research in Electrical, Electronics and Instrumentation Engineering

(A High Impact Factor, Monthly, Peer Reviewed Journal)

Website: www.ijareeie.com

Vol. 6, Issue 9, September 2017

i. Barometer test

The first sensor to be tested was the BMP085 (barometer). This sensor uses atmospheric pressure to estimate the altitude of the quadcopter in meters. This sensor is needed to implement altitude-hold; a flight mode that attempts to keep the quadcopter at the same altitude. The team tested three methods to improve the accuracy and precision of the barometer; control (no action); adding a foam sponge cover; and adding a mesh cover. The mesh cover proved ineffective as it made the altitude-hold worse by inspection. The remaining two options were tested in a number of different ways. One test was flying the quadcopter up to two meters and seeing which method provided better altitude-hold. The results are seen in Table 4 below.

	Control	Foam
Average	0.79	1.84
Median	0.72	1.90
Standard Dev.	0.40	0.27

Table 4: Altitude-Hold tests with control and foam covers (meters)

Standard deviation was considered the most important metric while testing. While accurate values would be ideal; the barometer itself measures only absolute pressure; thus it was more important that the sensor's standard deviation was the smallest as this signified the best hold at a given altitude. As is shown from the results; a foam cover improved the barometer in both accuracy and precision; and thus was implemented on the flight controller. No alternative foam covers were explored due to time constraints for the prototype.

ii. Compass test

The other sensor that underwent unit tests on the flight controller was the HMC5883L (compass). In order to track the vehicle correctly; one must know where the quadcopter is pointed so that it can turn to follow the vehicle. Because of this; unit tests were performed to ensure the accuracy and precision of the compass. It became quickly obvious that the compass was not operating correctly when the first flights were completed. Under motor power; the compass value would skew over 50 degrees on a 360-degree scale. After preliminary tests; and discussions with consultants as well as research online; the source of the interference was found to be magnetic fields emitted from the power distribution board. The best way to shield against this interference was simply to increase the distance between the compass (and the flight controller on which it is mounted) and the source of interference.

Once the quadcopter was reassembled; the compass was tested again to prove the changes. The skew resulting from motor power was under two degrees; much improved from the original case. The quadcopter was then flown in a heading-hold mode. The purpose of this flight mode is to keep the quadcopter's orientation throughout a flight.

iii. Motor test

The motors were tested to lift the quadcopter and its components successfully (1.3kg). Above that; the motors were able to lift an additional 0.9 kg. The prototype was able to fly over 15 km/hr. meeting the prototype requirement; but the maximum speed was not tested out of concern for a crash that could occur during this test.



International Journal of Advanced Research in Electrical, Electronics and Instrumentation Engineering

(A High Impact Factor, Monthly, Peer Reviewed Journal)

Website: www.ijareeie.com

Vol. 6, Issue 9, September 2017

iv. Battery test

We had access to several different battery sizes from which they could perform battery life tests. The prototype; which included the Flight time and camera accessories; had an average current draw of 23.95A. With the largest 5100 mAh battery; the quadcopter was able to meet the requirements for flight time. Figure 4 shows the results including the production battery and Figure 5 below shows the flight time with the five batteries available for the prototype

Capacity (mAh)	Flight time (min)
2450	6.34
3000	7.62
4000	8.81
5100	9.80
11;975*	20.46

*estimated battery size for production model

Table 5: Battery Capacities and Flight Times.

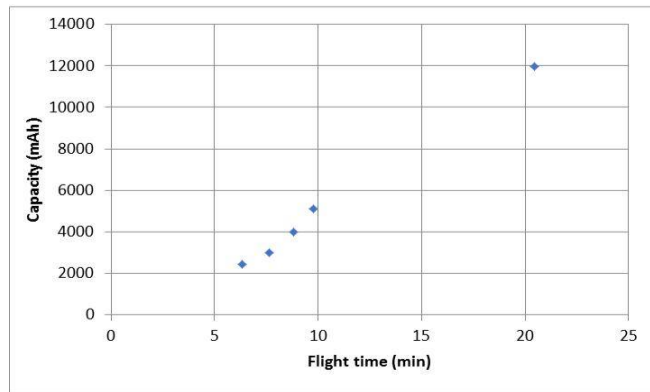

Figure 4: Flight times with various battery sizes.

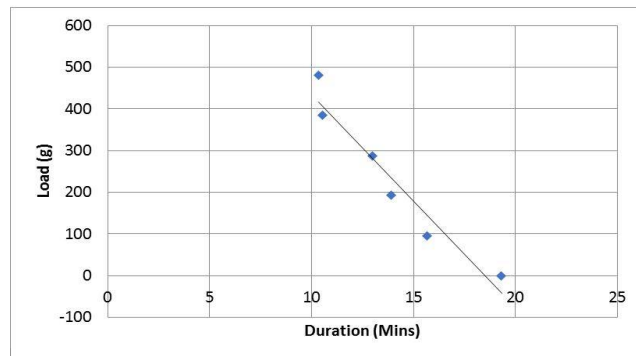

Figure 5: Fixed vertical flight test



International Journal of Advanced Research in Electrical, Electronics and Instrumentation Engineering

(A High Impact Factor, Monthly, Peer Reviewed Journal)

Website: www.ijareeie.com

Vol. 6, Issue 9, September 2017

6.2. Flight tests

Pre-flight testing (tethered) and post-flight testing (untethered) methods were used for the testing of the quadcopter. For the pre-flight testing a checklist was used to ensure that the quadcopter was in sound condition before the post-flight testing.

i. Pre-flight test

- i. The speed controller and motor were connected to battery. Then speed controller was switched on. The speed controller controlled the speed of the fan according to preassigned conditions on the IMU sensors. Speed of the fan increased as the surrounding air pressure increased and it decreased as the air pressure decreased. Increment of both air pressure and speed can be changed according to user preferences by the modification in programming. So the speed controller performed as per the design.

S/N		YES	N/A	NO	RECOVERY ACTION
1.	Airframe and Landing Gears intact?				Ensure the airframe and landing gears are intact.
2.	Propellers secured; undamaged and in correct flying orientation?				Ensure that the propellers are secured; undamaged and in correct flying orientation.
3.	Motors secured and undamaged?				Ensure motors are secured and undamaged.
4.	ESCs secured and undamaged?				Ensure that ESCs are secured and undamaged.
5.	GPS receiver and Cable secured and undamaged?				Ensure that the GPS receiver and cable are secured and undamaged.
6.	RC receiver and connections secured and undamaged?				Ensure that that RC receiver and connections are secured and undamaged.
7.	RC satellite (remote) Receiver and cable secured and undamaged?				Ensure that the RC remote receiver is secured and undamaged.
8.	APM 2.6 flight controller secured and undamaged?				Ensure that APM 2.6 flight controller is secured and undamaged.
9.	Battery fully charged?				Ensure that the battery is fully charged.
10.	Battery correctly installed and connected on the quadcopter?				Ensure that battery is correctly installed and connected on the



International Journal of Advanced Research in Electrical, Electronics and Instrumentation Engineering

(A High Impact Factor, Monthly, Peer Reviewed Journal)

Website: www.ijareeie.com

Vol. 6, Issue 9, September 2017

				quadcopter.
12.	Battery correctly strapped and secured?			Ensure that the battery is correctly strapped and secured.
13.	IR sensor powered; correctly secured and undamaged?			Ensure that IR sensor is powered; correctly secured and undamaged.

Table 6: Pre-Flight checklist quadcopter.

S/N		YES	N/A	NO	RECOVERY ACTION
1.	Laptop PC powered on?				Power on the PC
2.	Laptop Battery at full lifespan?				Recharge the PC battery to full charge.
3.	Mission Planner software running?				Running the Mission Planner software.
5.	Telemetry Ground Module antenna orientation vertical?				Turn the antenna to vertical position.
6.	Com Port Settings in Mission Planner at baud rate 115200				Set baud rate at 115200
7.	Ground Station PC receiving real-time signals from IR sensor?				Ensure that the Ground Station PC is receiving IR signals from onboard IR sensor.
8.	Quadcopter range in check?				Ensure that range check of quadcopter is carried out.

Table 7: Ground station

ii. Post-flight test

- i. The next test was actual flight time with loads ranging from 0 grams to 480 grams. AA batteries were used as the load; the batteries weigh 24 grams each and are easy to attach over the entire vehicle to distribute the load. The tests were conducted in both the tethered and untethered modes. The results of the constrained test are shown in Table 9. These results were verified by flying the quadcopter unconstrained with a weight of 96 grams and 480 grams to check performance differences at the two extremes and to determine the effects of the quadcopter being constrained during testing. During the test the quadcopter was flown at approximately five feet off the ground and the control board was set to stabilize flight.
- ii. A maximum speed test was also conducted; to do this the quadcopter was taken out to a large field and flown at max throttle straight up and then brought back down to the ground. The APM 2.6 recorded flight data which could then be viewed using the mission planner application. During the flight test the quadcopter reached a maximum speed of 39 mph with no load.
- iii. The final test conducted was an unbalanced load test. To conduct the test a load was placed under an individual motor. This test was conducted to determine the effects of an unbalanced load on the duration of flight the quadcopter could achieve. The test was only done with three weight increments; this is because at the 288 gram load the quadcopter began behaving abnormally during flight and the risk of damage at a higher weight was deemed too great. The quadcopter was



International Journal of Advanced Research in Electrical, Electronics and Instrumentation Engineering

(A High Impact Factor, Monthly, Peer Reviewed Journal)

Website: www.ijareeie.com

Vol. 6, Issue 9, September 2017

able; until the 288 gram load; to easily adjust its power between the motors to achieve level flight. The results for this test are shown in table 10.

Post-flight testing was carried out using the checklist below:

S/N		Yes	N/A	No	Recovery action
1.	RC Transmitter throttle's stick at minimum?				Ensure that the RC transmitter throttle stick is at minimum.
2.	RC Transmitter fully charged?				Ensure that RC transmitter is fully charged.
3.	RC Transmitter powered ON?				Ensure that RC transmitter is powered ON.
4.	RC Transmitter Model correctly selected?				Ensure that RC transmitter Model is correctly selected.
5.	RC Transmitter mode switch stabilized?				Ensure that RC transmitter mode switch is stabilized.
6.	Quad placed at RTL location?				Ensure that quad is placed at remote takeoff location
7.	Telemetry communication systems connected with MP to quad?				Ensure that telemetry communication systems are connected.
8.	Telemetry Antenna straight and vertical?				Ensure that telemetry antenna is straight and vertical.
9.	RC receiver Antennas straight?				Ensure that RC receiver antennas are straight.
10.	Quad LIPO battery voltage fully charged?				Ensure that quad LIPO battery voltage is fully charged
11.	Battery connected and secured to quadcopter?				Ensure battery is connected and secured on the quadcopter.
12.	Battery cables secured?				Ensure that battery cables are secured before takeoff.
14.	Pitch & roll; AV...				Ensure correct response on AH.
15.	Air speed verified at 0 (± 3)?				Ensure correct response on AH.
16.	Home altitude set?				Ensure that home altitude is set.
17.	Altitude verified at 0 (± 3)?				Ensure correct response on AH.
18.	GPS 3D fixed?				Ensure GPS is fixed at 3D.
19.	Flight plan verified?				Verify flight plan.
20.	IR real-time response signal receiving?				Ensure quad is within WIFI 100m range.

Table 8: Post-Flight checklist.



International Journal of Advanced Research in Electrical, Electronics and Instrumentation Engineering

(A High Impact Factor, Monthly, Peer Reviewed Journal)

Website: www.ijareeie.com

Vol. 6, Issue 9, September 2017

After carrying out proper pre-flight and flight checks; the various units were checked and the systems powered as recommended by the safety guideline to ensure safety of the quadcopter and the personnel operating it.

VII. RESULTS

After concluding the pre-flight testing using the checklists above; the following results were noted and corrections were attempted where necessary (Table 9-10), (Figure 6).

Load (grams)	Duration (Mins)
0	19.32
96	15.69
192	13.88
288	13.00
384	10.52
480	10.36

Table 9: Fixed vertical flight test results.

Load (grams)	Duration (min)
96	14.85
192	13.94
288	12.23

Table 10: Unbalanced Load Results

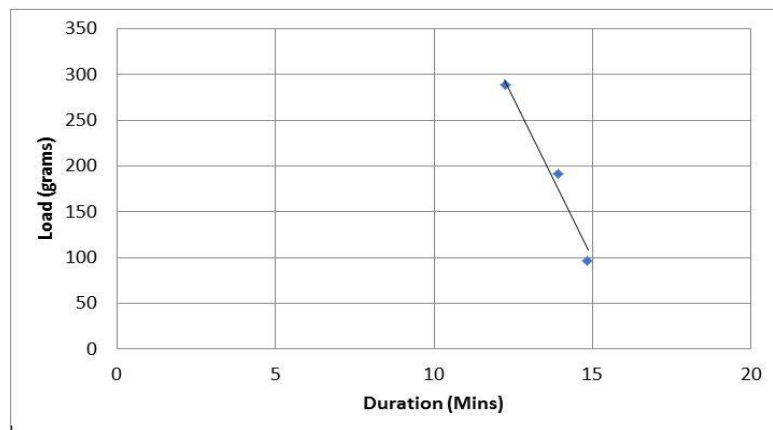

Figure 6: Unbalanced load



International Journal of Advanced Research in Electrical, Electronics and Instrumentation Engineering

(A High Impact Factor, Monthly, Peer Reviewed Journal)

Website: www.ijareeie.com

Vol. 6, Issue 9, September 2017

IX. CONCLUSION

It may be mentioned that the platform which we have created is capable of sustaining autonomous flight at a height of 20 feet at a range of 30 meters. While this in essence proves to be short of our ultimate goal; we have created a proven and solid platform for later development. Our platform can be outfitted with additional sensors (cameras; IR sensors; wireless technology; and 3D mapping tools; etc.) to expand the overall usefulness and flexibility of the quadcopter design. The capabilities of this design may prove to be asymptotic in nature; however these may not be realized until proper funding is given and experimental analysis is conducted. The result suggests that we were able to create a sustainable and flexible platform for an Unmanned Aerial Vehicle (UAV) capable of carrying out inspection in real-time on a pipeline facility.

REFERENCES

- [1] Breguet-Richet; The Breguet Gyroplane 1907; Wikipedia.
- [2] Clym; Montgomery; Multi-rotors first-person view; and the hardware you need; tom's HARDWARE 1947; 1: 6.
- [3] Convertawings; Model A Quadrotor 1956; Wikipedia.
- [4] Curtiss-Wright; VZ-7 multicopter 1958; Wikipedia.
- [5] Drew B; Robert H; Spencer O; Jared Z; Engineering 339/340 Senior Design Project Calvin College. 2014.
- [6] de Bothezat; Helicopter Model. 1922; Wikipedia.
- [7] Etienne Oehmichen No.2 1920.
- [8] Harsh Kothari; Advantages of using c++ over c; Quora 1-2.
- [9] AHB Mustaffa; Stability Control for Quadcopter with an Autonomous Flight System. 2012; 3-5
- [10] D Roberts; Construction and Testing of a Quadcopter. San Luis Obispo 3-6.
- [11] Srikanth B; Rakesh M; Siddharth S; Anand K; Radio Controlled Quadcopter. 10-12
- [12] Vinod I; Umar M; Quad Copter Controlling using Android Mobile Devices; International Journal of Innovative Research in Computer and Communication Engineering 2015; 3.
- [13] Orji U; Design and construction of a quadrotor for pipeline inspection; 2014; 46-70
- [14] Justin P; Andrew N; Andy B; Quad-Rotor UAV project; Final Report 2010.
- [15] Øyvind M; Kjell S; : *Modeling; Design and Experimental Study for a Quadcopter System Construction*; Final year project report; Faculty of Technology and Science; University of Agder.