



DTMF based Home Automation System

Amrit Kumar Panigrahi¹, Reshav Ranjan², Subhasish Bhoi³, Neha Kumari⁴

Assistant professor, Department of EEE, GIET, Gunupur, Odhisha, India¹

B.Tech Scholar, Department of EEE, GIET, Gunupur, Odhisha, India^{2,3,4}

ABSTRACT: The paper presents an approach of the designing of a home automation system using DTMF. DTMF stands for Dual Tone Multi Frequency. The system allows users to send commands from their cell phones to control various home appliances such as bulb, fan etc. Commands are sent via a cell phone's numeric code dialling capability. The system is equipped with DTMF decoder and relay module for controlling any appliance. The program code is fed onto the micro-controller. The main advantage of the circuit is its vast range. We can track the status and control our home appliances from anywhere. In our system we have used four bulbs to represent AC loads and a 12V transformer to power the circuit.

KEYWORDS: Home Automation, DTMF decoder, Arduino UNO, 4 Channel Relay, Cell-phone etc.

I. INTRODUCTION

Conventionally, electrical appliances in a home were controlled via switches that regulate the electricity to these devices. Today, we have entered the era of technology. Gone are the days where manual operation was performed. Home automation is becoming more popular around the world and is becoming a common practice. Smart home automation becomes important, because it provides the user the comfort and easy access to the home appliances. The process of home automation works by making everything in the house automatically controlled, using technology to control and do the jobs that we would normally do manually. Home automation takes care of a lot of different activities in the house. In this project, we propose a unique System for Home automation utilizing Dual Tone Multi Frequency (DTMF) that is paired with a wireless module to provide seamless wireless control over many devices in a house. We can operate our system from any distant or remote area. It is a wireless system but instead of using a separate wireless module (transmitter and receiver) we are using the cell phones for this purpose. Cell-phone operated system is having a wide range (service provider range), less fear of interference as every call is having a unique frequency and moreover it has more control keys. The principle used for cell-phone controlled system is the decoding of DTMF tone. DTMF stands for Dual Tone Multi Frequency. The main components used here are the DTMF Decoder, Arduino UNO and the relay module. With the inter-connection of these components and with use of a cell phone as a remote we were successful in controlling various home appliances. For this the system we have used lamps to demonstrate AC loads and a 12V transformer to power the system. The advantages of using this technology are many. One can control home appliances from anywhere in the world. It helps in reducing the wastage of electricity. The cost for this system is also less as compared to other technologies like GSM.

II. PROJECT DESCRIPTION

A. POWER SUPPLY

Power supply is a reference to a source of electrical power. A power supply unit or PSU can be defined as system that provides electrical or other types of energy to a load or group of loads connected to it. Here in our system we require a 5v DC power supply for all electronic components involved in the project. This requires step down transformer, rectifier, voltage regulator, and filter circuit for generation of 5v DC power.

International Journal of Advanced Research in Electrical, Electronics and Instrumentation Engineering

(An ISO 3297: 2007 Certified Organization)

Vol. 6, Issue 3, March 2017

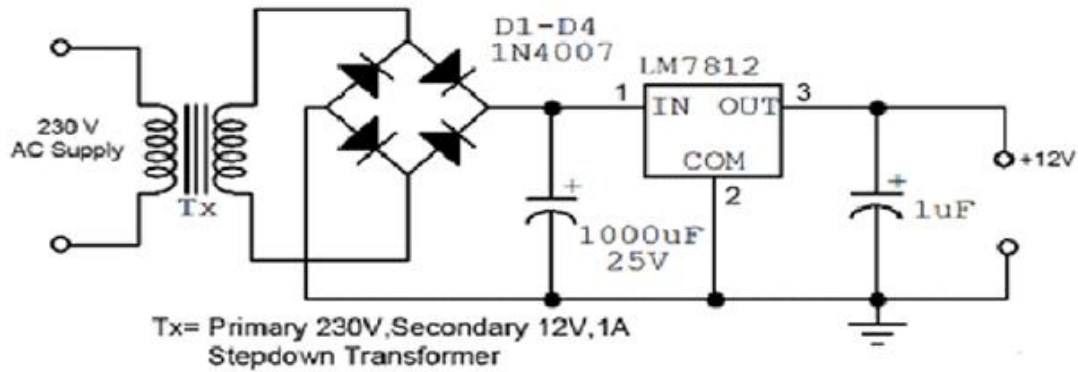

Fig. 1: Power Supply circuit

B.ARDUINO UNO

Arduino is an open source electronics prototyping platform that is flexible, easy-to-use hardware and software. It is designed for artists, designers, hobbyists and anyone interested in creating interactive objects or environments. Arduino Uno is basically based on ATmega328 microcontroller (MCU). It consists of 14 digital input/output pins, six analogue inputs, a USB connection used for programming the onboard MCU, a power jack, an ICSP header and a reset button. It is operated with the help of a 16MHz crystal oscillator and contains everything needed to support the MCU. It is very easy to use as we simply need to connect it to a computer using a USB cable, or power it with an AC-to-DC adaptor or battery to get started. The MCU onboard is programmed in Arduino programming language using Arduino IDE.



Fig. 2: Arduino UNO

C.DTMF DECODER

The DTMF Decoder (MT8870) is a device which is used to decode the DTMF tones generated by the dialler keys of a cell-phone. It integrates both the band split filter and digital decoder functions. The decoder utilizes the digital counting techniques to detect and decode all 16 DTMF tone-pairs into a 4-bit binary code. For e.g. - if a user dials '1' in his key-pad the output generated by the decoder is 0001 and so on. The output of the DTMF decoder can be used to drive home appliances.

International Journal of Advanced Research in Electrical, Electronics and Instrumentation Engineering

(An ISO 3297: 2007 Certified Organization)

Vol. 6, Issue 3, March 2017

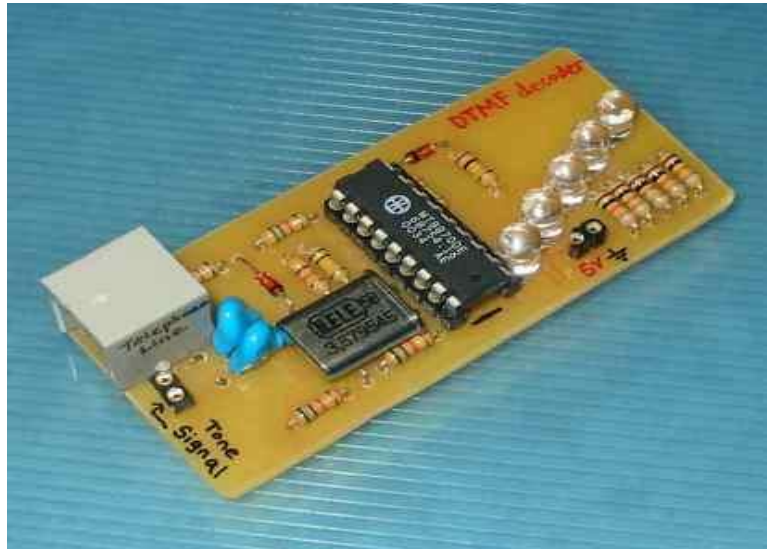

Fig.3: DTMF Decoder (MT8870)

D.FOUR-CHANNEL RELAY MODULE

A relay is a device which allows us to turn on or turn off a circuit with voltage and/or current which is much higher than what Arduino could handle. Relay provides complete isolation between the low-voltage circuit placed on the Arduino side and the high-voltage side which is connected to the load. For this project we have used a 4 channel, 5V relay. This 5V 4-channel relay interface board and each channel needs a 15-20mA driver current. It can be used to control various home appliances and equipment with large current. It has a standard interface that can be controlled directly by microcontroller.

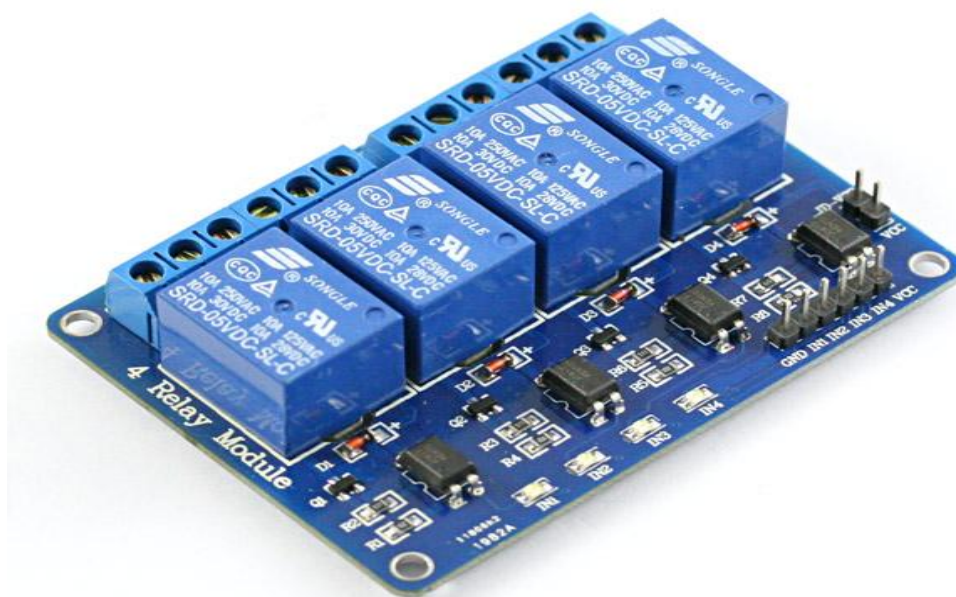

Fig. 4: Four-channel Relay Module

International Journal of Advanced Research in Electrical, Electronics and Instrumentation Engineering

(An ISO 3297: 2007 Certified Organization)

Vol. 6, Issue 3, March 2017

III. BLOCK DIAGRAM

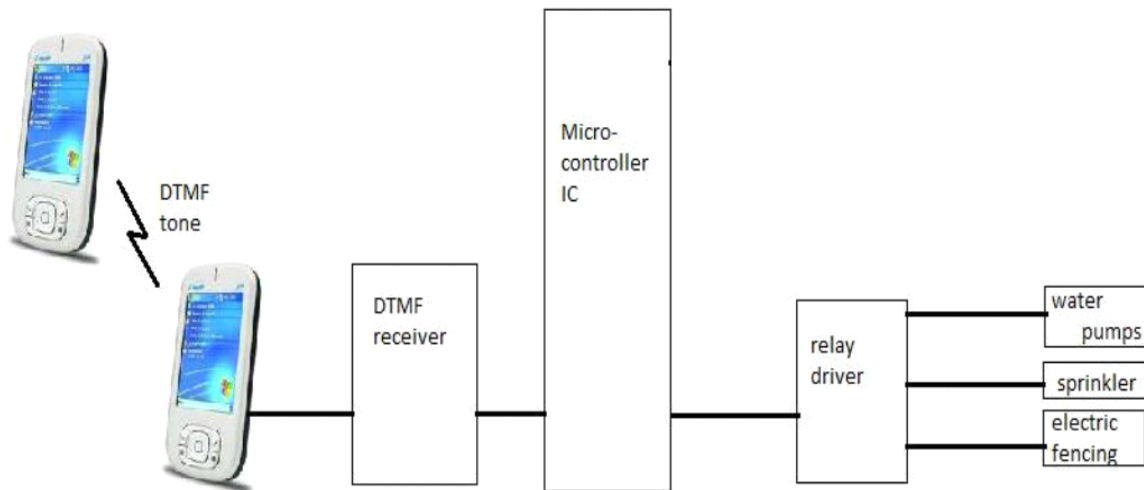

Fig. 5: Block Diagram

The above figure (5) depicts the block diagram of the entire system. When the user dials the home telephone number the telephone at home rings and if nobody picks the call, then the system picks up the call automatically. When we press any number on the phone keypad it generates a particular frequency, which is received by the other phone and then the code/number is decoded by the DTMF decoder /receiver. Here the decoder decodes the frequency of the tone generated by the particular code/number. The DTMF decoder generates a binary output which is given to the micro-controller. Here a program code is fed to the microcontroller which activates the relay module according to the key pressed by the user. At the output of the microcontroller the devices are connected to a 4-channel relay module. It is a driver which drives the appliances based on the microcontroller output. Thus, when the relay drive is activated by the microcontroller, the device either gets ON or is switched OFF as per the requirement. Our project makes use of auto answer facility and hence eliminates the need of a ring detector circuit.

IV. CONNECTION LAYOUT

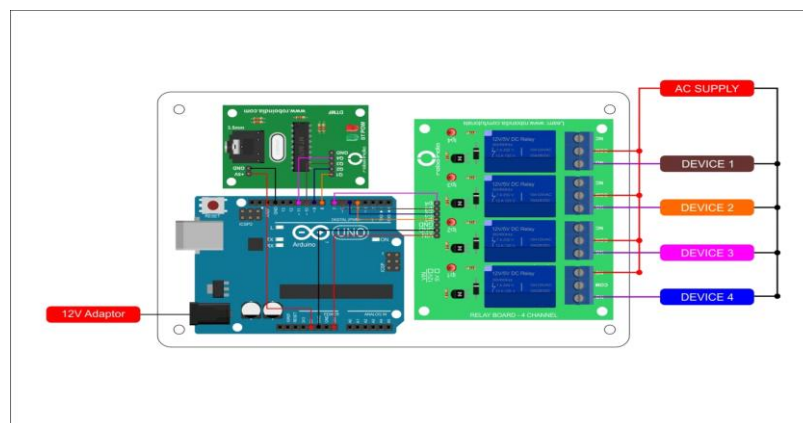

Fig. 6: Connection layout of the hardware

The figure '6' shows the connection of the DTMF decoder and the relay module with the Arduino UNO. The DTMF Decoder, Arduino UNO and the relay module gets the DC supply from the power supply unit. The DTMF decoder



International Journal of Advanced Research in Electrical, Electronics and Instrumentation Engineering

(An ISO 3297: 2007 Certified Organization)

Vol. 6, Issue 3, March 2017

(MT8870) is connected to the Arduino UNO which in turn is connected to the relay module. The output of the relay module is connected to various loads. In our project we have used four loads (bulbs) for demonstration. The entire connection is made through jumper wires.

V. RESULTS

In our testing we found that our system is operating successfully. When the call is initiated and the keys are pressed upon the cell-phone, the DTMF decoder decodes the signal into binary form. This is further processed by the microcontroller to generate the specific signal to drive the relay module for driving the output devices connected to it.

The key pressed by the user, the binary code output by the DTMF decoder and the resulting action performed by the driving circuit is shown in TABLE 4.1 below.

KEY PRESSED	BINARY CODE	ACTION PERFORMED BY THE DRIVING CIRCUIT
1	00000001	Device 1 will be ON.
2	00000010	Device 1 will be OFF.
3	00000011	Device 2 will be ON.
4	00000100	Device 2 will be OFF.
5	00000101	Device 3 will be ON.
6	00000110	Device 3 will be OFF.
7	00000111	Device 4 will be ON.
8	00001000	Device 4 will be OFF.
9	00001001	All devices will be ON.
0	00001100	All devices will be OFF.

Table 1: Output Obtained

International Journal of Advanced Research in Electrical, Electronics and Instrumentation Engineering

(An ISO 3297: 2007 Certified Organization)

Vol. 6, Issue 3, March 2017

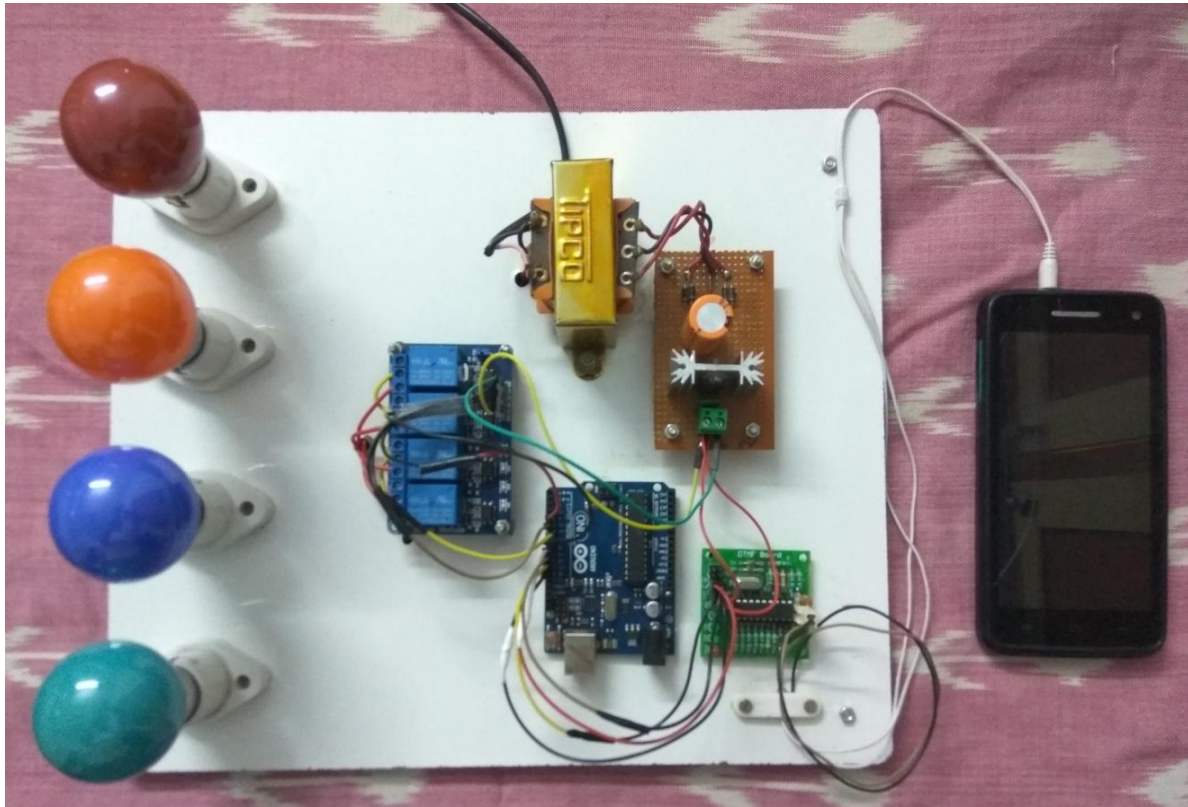

Fig. 7: Assembled Model

VI. CONCLUSION

Our effort towards developing a cell-phone controlled home appliances system was successful. It is an excellent device to operate any electronic equipment from miles away. This system can prove to be very useful in rural areas as well the device control can be applied in every field like agriculture, home, factories etc. The utilization of mobile communication in device control has been thoroughly justified and the previous drawbacks and problems have been overcome. This project can be further extended to the High voltage A.C appliances by changing the ratings of the relay. Monitoring of the high speed induction motors as well as synchronous motors would also be possible. We can also add some security features in the proposed system. One of the ways is password protection. Through this feature, only authenticated users can access this control over the home appliances. In this project in future we can add a multimedia camera to see what is going inside the home by sitting in office or somewhere else. In this way we can keep track of our appliances at home when we are busy at workplace and without any worry we can perform our task. So with the utilization of this vast telephone network we can control our home appliances easily and economically.

REFERENCES

- [1] N. Sriskanthan and T. Karand, Bluetooth Based Home Automation System, Journal of Microprocessors and Microsystems, 26, 2002, 281-289.
- [2] M. I. Ramli, M. H. AbdWahabandN. Ahmad, Towards Smart Home: Control Electrical Devices Online, International Conference on Science and Technology: Application in Industry and Education 2006.
- [3] Al-Ali, (Member, IEEE)& M. AL-Rousan,,Java-Based Home Automation System R. IEEE Transactions on Consumer Electronics, 50(2), MAY 2004.
- [4] G.B.Pradeep,B.SanthiChandra,M.Venkates-warao, Ad-Hoc Low Powered 802.15.1 Protocol Based Automation System for Residence using Mobile Devices, Dept.of ECE, K L University, Vijayawada, Andhra Pradesh, India, IJCST, 2, SP 1, December 2011.
- [5] E. Yavuz, B. Hasan, I. Serkan and K. Duygu. Safe and Secure PIC Based Remote Control Application for Intelligent Home. International Journal of Computer Science and Network Security, 7(5), May 2007.



ISSN (Print) : 2320 – 3765
ISSN (Online): 2278 – 8875

International Journal of Advanced Research in Electrical, Electronics and Instrumentation Engineering

(An ISO 3297: 2007 Certified Organization)

Vol. 6, Issue 3, March 2017

- 6] R.Piyare and M. Tazil, Bluetooth Based Home Automation System Using Cell Phone, IEEE 15th International Symposium on Consumer Electronics, 2011.
- [7] S.R. Das, S. Chita, N. Peterson, B. A. Shirazi and M. Bhadkamkar, Home automation and security for mobile devices, IEEE PERCOM Workshops, 2011, 141-146.
- [8] I. Laur, Microcontroller based home automation system with security, International Journal of Advanced Computer Science and Applications, 1(6), 2010, 60-65.
- [9]. Dong-ying Ju; Rui Zhong; Takahashi, M.; Saitama Inst. of Technol., Saitama. Development of Remote Control and Monitor System for Autonomous Mobile Robot Based on Virtual Cell Phone Innovative Computing, Information and Control, 2007. ICICIC '07. Second International Conference ISBN: 0-7695-2882-1.
- [10]. A P Bagade, S L Haridas and P R Indurkar. Article: Development of a Mobile Based Device Remote Control with Voice Acknowledgment. IJCA Proceedings on National Conference on Innovative Paradigms in Engineering and Technology (NCIPET 2012) ncipet(2):29-30, March 2012. Published by Foundation of Computer Science, New York, USA.
- [11]. Ahmed, V.; Ladhake, S.A.; Electron. Eng. Dept., Babasaheb Naik Coll. of Eng., Pusa, India. Innovative Cost Effective Approach for Cell Phone Based Remote Controlled Embedded System for Irrigation Communication Systems and Network Technologies (CSNT), 2011 International Conference on ISBN: 978-1-4577-0543-4.
- [12]. Sagarika Pal, Niladri S. Tripathy¹ Department of Electrical Engineering, National Institute of Technical Teachers Training and Research, Kolkata. Remote Position Control System of Stepper Motor Using DTMF Technology. International Journal of Control and Automation Vol. 4 No. 2, June, 2011.
- [13]. Dodd, Annabel Z. The essential guide to telecommunications. Prentice Hall PTR, 2002, pp. 183.
- [14]. Frank Durda, Dual Tone Multi-Frequency (references)
- [15]. Alkar, A. Z., & Buhur, U. (2005). An Internet Based Wireless Home Automation System for Multifunctional Devices. IEEE Consumer Electronics, 51(4), pp. 1169-1174