



ISSN (Print) : 2320 – 3765
ISSN (Online): 2278 – 8875

International Journal of Advanced Research in Electrical, Electronics and Instrumentation Engineering

(An ISO 3297: 2007 Certified Organization)

Website: www.ijareeie.com

Vol. 6, Issue 6, June 2017

Permanent Magnet Synchronous Generators Connected to Grid - Comparative Study between DC and AC Configurations

Rupali H.Patil¹, Dr.Hari Kumar Naidu², Pratik Ghutke³

P.G Student, Department of Electrical Engineering and Technology, Tusiramji Gaikwad-Patil College of Engineering
& Technology, Nagpur, India

HOD, Department of Electrical Engineering and Technology, Tusiramji Gaikwad-Patil College of Engineering &
Technology, Nagpur, India

Guide, Department of Electrical Engineering and Technology, Tusiramji Gaikwad-Patil College of Engineering &
Technology, Nagpur, India

ABSTRACT: This paper presents simple and effective control strategies for the active rectifier stage (ac/dc stage) of a grid connected low-power system for micro wind applications employing permanent magnet synchronous generator (PMSG). In particular, a novel algorithm for the estimation of the rotor angle of the PMSG, based on flux estimators, was implemented using an adaptive low-pass filter coupled with a feed-forward compensator. This enabled a very smooth start-up operation of the PMSG, obtained by preloading the values of the flux estimator. The wind turbine grid side is to establish maximum power delivery to the grid from available wind power. Fully-controlled wind turbine which consists of induction generator and back-to-back converter is under estimate. This configuration has full control over the electrical torque, full control of the speed, and also supports reactive power compensation and operation under grid disturbances. Simulation and experimental results confirmed the effectiveness of the proposed solutions expected and the maximum power transferred to load with the minimum total grid current harmonic distortion are negligible.

KEYWORDS: Digital Control, Power Conversion, Pulse Width Modulation, Rectifiers, Wind Energy.

I. INTRODUCTION

In micro wind turbine applications, permanent magnet synchronous generator (PMSG) is widely used. Two power conversion stages are present: the ac/dc and dc/ac stage. In grid-connected systems, two major topologies for the first ac/dc power conversion are used: diode-bridge passive rectifier followed by a boost converter or a three-phase fullbridge active rectifier (back-to-back converter) (Fig1). For very low-power micro wind systems (with rated powerless than 5 kW), the most usual topology for the ac/dc stage is the diode-bridge followed by a boost converter. The dc/ac power conversion stage is often a full-bridge topology, which injects the electric power into the grid. The global ac/ac conversion task to be accomplished by a wind power converter can also be implemented, without the intermediate dc link, by means of a matrix converter. However, its application to single-phase systems presents inherent problems due to the limited energy storage capability characteristic of this topology. In literature, several works regarding back-to-back converter application to wind system

are presented, mostly focused on high-power systems. Since the active rectifier stage is effectively employed as a full- featured motor drive, the application of the back-to-back topology even to low-power system presents several advantages such as improved system efficiency, bidirectional power transfer, and superior overload characteristic (i.e., emergency braking torque) . The control of a back-to-back power converter is usually implemented on a single digital signal processor (DSP). The widespread approach implies that the two controllers implement a current loop, while the dc-link voltage control associated with the grid-connected converter, and the active rectifier draws the maximum

International Journal of Advanced Research in Electrical, Electronics and Instrumentation Engineering

(An ISO 3297: 2007 Certified Organization)

Website: www.ijareeie.com

Vol. 6, Issue 6, June 2017

available power from the wind turbine. While this solution allows a good control of the power conversion system, it is not indicated for modular systems. In the framework of residential installation, a modular architecture is useful to integrate a multiplicity of renewable energy sources in a local micro grid.

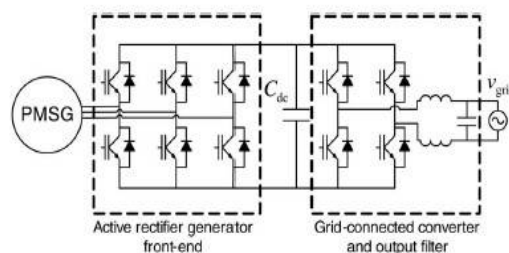

Fig. 1. Topology of a back-to-back converter.

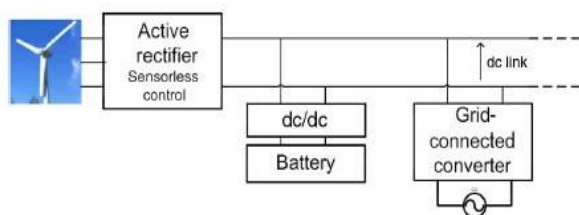

Fig. 2. Application of the proposed active rectifier into a modular system.

This paper describes the control strategy of an active rectifier suitable for modular systems, with smooth transitions between dc-link voltage control and maximum power point tracking (MPPT). In this way, different kinds of converters can be connected to the dc link, such as a grid-tied converter or a dc/dc converter for energy storage systems, without the need of a dedicated communication between the power stages, as shown in Fig. 2. This goal was achieved by developing a dedicated state machine for the control of the modular power system. Several sensorless algorithms were presented in literature. The most investigated solutions can be divided into the ones that estimate the back electromotive forces (backEMFs) of rotor flux and the ones that rely upon the magnetic anisotropy of the machine. In the first algorithm, the EMF is calculated from the voltages applied to the PMSG, basically by employing the machine model to compensate the voltage drop across the motor impedances. Other techniques calculate the sliding-mode observer (SMO) is a control technique that makes a reference model to converge with the actual measure, and the output of this procedure is the back-EMF. Generally, the sign function is adopted as a controller, thus causing high-frequency chattering of the estimation variables. In order to limit the high frequency estimation noise, low-pass filters (LPFs) are used, but they introduce an unacceptable delay in the estimation of the angle. Other approaches employed a sigmoid function instead of the sign function in order to reduce the chattering of the estimated variables. This allows to remove the LPF, because the output of the SMO is free from high-frequency content. There are two main disadvantages of this approach: 1) the sigmoid function represents a considerable computational burden for low-cost DSP and 2) the chattering is not completely removed, as the boundaries for the sigmoid function need to be adjusted in relation to the rotational speed in order to guarantee a good response time together with little high-frequency noise. Another approach relies on extended Kalman filters (EKF) for the estimation of the rotor angle, which allows for very good tracking performance, even in the presence of high level of noise in the measure.

II. WIND TURBINES

In the event that the mechanical vitality is utilized specifically by apparatus, for example, a pump or crushing stones, the machine is typically called a Windmill. A wind turbine is a machine for changing over the active vitality in wind into mechanical vitality. In the event that the mechanical vitality is then changed over to power, the machine is known as a wind generator. As wind turbines increment in size and ascend to more noteworthy statures to exploit higher vitality winds, their towers require more materials and contain a bigger rate of the venture's expense. Proficient

development strategies can improve material amounts and decrease costs.

III. ACTIVE RECTIFIER CONVERTER

The active rectifier behaves like a full-featured PM motor drive performing an FOC. In this paper, a flux estimator based on the integration of the terminal voltage is employed. The drawbacks of this approach (pure integration and slow response in the DC offset rejection) are addressed with a modified structure which allows for a very small tracking error even at low speed together with a good dynamic response. The control strategy does not present excessive computational load and can be implemented even on low-cost processors. Moreover, this paper proposes, with the use of an auxiliary voltage sensor, a particular strategy which can obtain a precise and smooth start-up operation for the PMSG. This is a very important feature for wind systems as it limits any excessive braking torque for the wind generator which could determine an undesired deceleration and stop of the wind turbine. Especially in the case of vertical axis wind turbines (VAWTs), the starting torque at cutin is very low and a sudden load from the generator can cause a stall or a deceleration until complete shutdown of the converter, then the start-up sequence repeats again, without reaching the steady-state operation. In order to improve the reliability, the energy harvesting, and to reduce the cost of the system, different additional controls were added to the basic FOC and described in the following sections.

A. Flux Estimator for PMSG Angle Estimation

Starting from the machine model on the $\alpha\beta$ coordinate system, the voltage equations can be written as follows (the sign of the currents is related to the generator convention):

$$\begin{cases} v_\alpha = -R_s i_\alpha - L di_\alpha/dt + d\lambda_{m\alpha}/dt \\ v_\beta = -R_s i_\beta - L di_\beta/dt + d\lambda_{m\beta}/dt. \end{cases} \quad (1)$$

In (1), $\lambda_{m\alpha}$ and $\lambda_{m\beta}$ are the flux components produced by permanent magnets, R_s is the phase resistance, and L is the synchronous inductance of the machine. It follows that the rotor flux can be expressed as

$$\begin{cases} \lambda_{m\alpha} = \int (v_\alpha + R_s i_\alpha) dt + Li_\alpha \\ \lambda_{m\beta} = \int (v_\beta + R_s i_\beta) dt + Li_\beta. \end{cases} \quad (2)$$

Indeed, in order to compute the rotor flux, an integration operation is needed. Simple integration in a real-time system is not feasible due to offset problems that will cause the integral memory to saturate. For this reason, the integrator was substituted with an LPF, which approximates the integral operator for frequencies well above the cut frequency. This represents one of the most adopted solutions for this kind of observer; however, in order to obtain an acceptable performance, the LPF pole must be located at a very low frequency. Even in this case, a residual phase and magnitude error in the flux estimation remains; furthermore, a digital implementation of this kind of filter can encounter problems due to numerical errors.

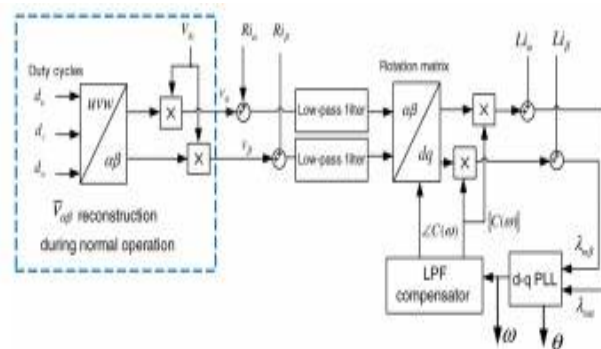

Fig. 3. Block schematic of the implemented flux estimator.

International Journal of Advanced Research in Electrical, Electronics and Instrumentation Engineering

(An ISO 3297: 2007 Certified Organization)

Website: www.ijareeie.com

Vol. 6, Issue 6, June 2017

B. Smooth Converter Start-Up

As explained in Section II-A, the FOC of the PMSG relies on the estimation of the rotor angle to correctly control the electric machine. However, as the phase voltages are calculated from the duty cycles and the dc-link voltage during the converter start-up (PWM-switching disabled), the estimation of $v_{\alpha\beta}$ has to be replaced with the use of one- or two-voltage transformers. The solution chosen for the present work is based on a single-voltage transformer connected between two phases of PMSG, i.e., phases u and v. With the information regarding $v_{\alpha\beta}$, the flux estimator is able to correctly compute the angle of the PMSG's rotor even before the actual PWM start-up, so that no transient for flux estimation block is present after the PWM start-up of the power converter.

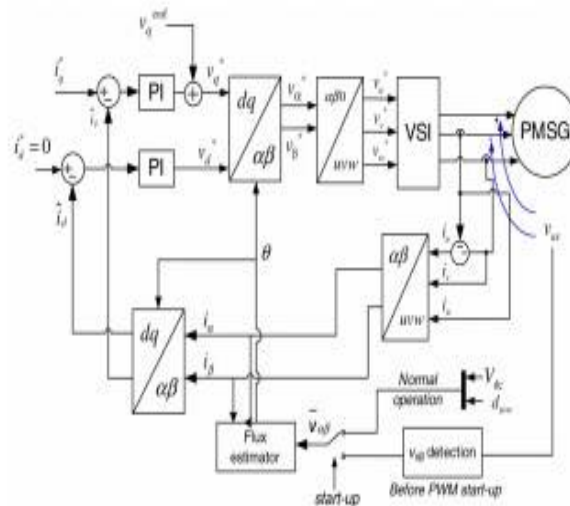

Fig.4. Block Schematic of the PMSG Torque Control

C. Maximum Power Point Tracking

The wind turbine converts kinetic energy from the wind into mechanical power and then into electrical power. For fixed-pitch turbines, the power curves at different wind speeds are similar to those depicted in Fig. 6. For every wind speed, there is a particular turbine speed that corresponds to the maximum power conversion (optimal tip speed ratio). A wind converter must control the turbine rotational speed in order to track the optimal tip speed ratio at different wind velocities; therefore, an MPPT algorithm should be implemented. With the knowledge of the turbine characteristics and the wind speed (that can be obtained with an anemometer), a speed controlled generator can harvest the maximum power from the wind. However, for small turbines, the anemometer is often not employed. For the application described in this paper, MPPT is implemented using an open-loop strategy, by controlling the electrical torque of the wind generator to the optimum value determined by the turbine characteristic. In particular, the measure of the generator speed ω , determined by the flux estimator (Fig. 3), is used to calculate the current set-point i

* q (Fig. 5).

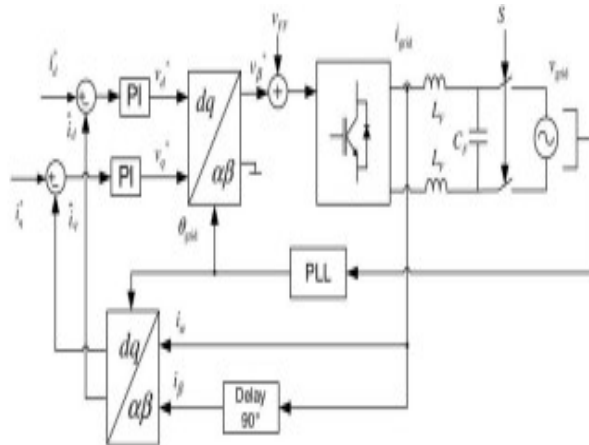

Fig.5. Block Schematic of the Implemented Grid Current Control

In the power derating zone, an active stall control is used [3], as in low-power wind systems the rotor blades are usually fixed. Lacking pitch control, mechanical power output can be limited by operating at a suboptimal tip-speed ratio, either by increasing or decreasing the rotating speed of the turbine. The generator speed is controlled by the FOC of the machine. Depending on the wind turbine, architecture, and safety concerns, decreasing the rotating speed below optimal tip-speed ratio is usually the only viable solution even if this causes a maximum torque of the generator higher than the torque produced at rated power. In this case, the electric machine and the power electronics must be oversized to satisfy turbine-braking requirements. If the power limit of the converter is not sufficient to keep the wind turbine in a safe operating area (i.e., below the maximum rotational speed), the converter quit operation (cut-out) and other safety mechanisms, usually mechanical brakes, intervene to stop the turbine.

IV. SIMULATION RESULTS

A. Proposed Simulation Circuit

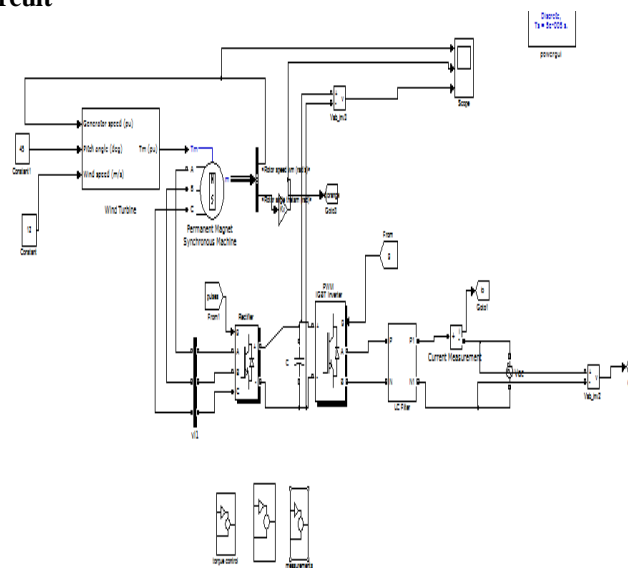

Fig.6. Control Circuit

International Journal of Advanced Research in Electrical, Electronics and Instrumentation Engineering

(An ISO 3297: 2007 Certified Organization)

Website: www.ijareeie.com

Vol. 6, Issue 6, June 2017

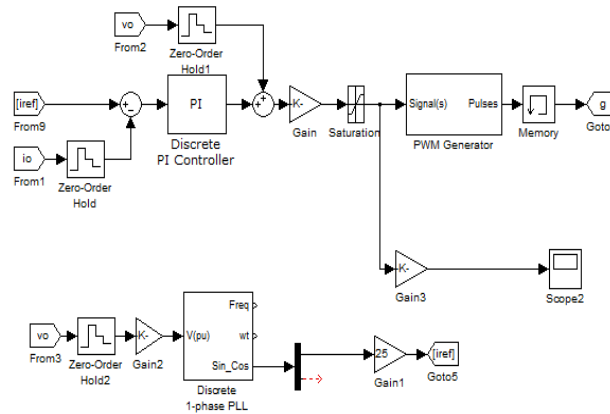

Fig.7. Simulation Results

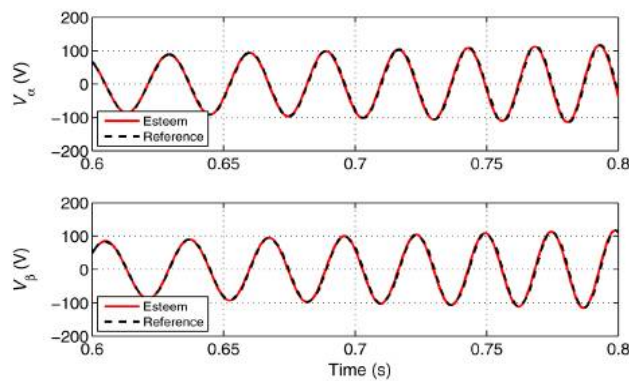

Fig.8. Reconstruction of $v_{\alpha\beta}$ before the PWM Turn-ON of the Active Rectifier Power Stage During An Acceleration of the PMSG.

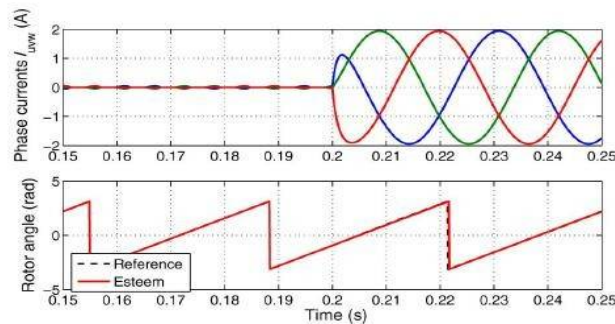

Fig.9. Electric Rotor Angle During a Step Variation of $I*Q$, with Constant PMSG Speed.

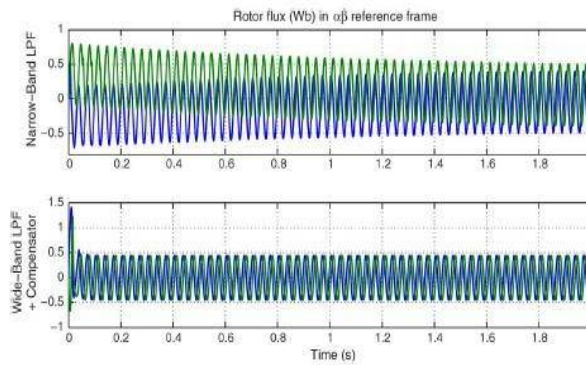

Fig.10. Calculation of $\lambda\beta$ in the Case of a Narrow (Cut Frequency 0.5 Hz) and Wide (Cut Frequency 50 Hz) Band Low-Pass Filter at the Power ON.

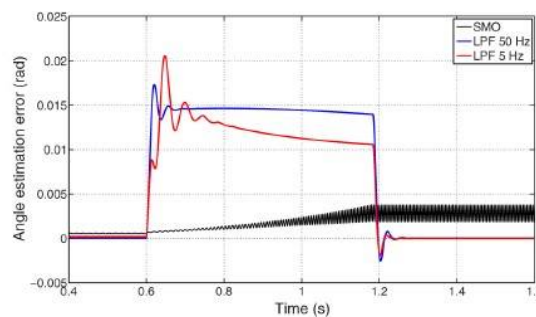

Fig.11. Angle Estimation Error in Case of a Generator Speed Variation from 90 to 300 Rpm (Electric Frequency from 15 to 50 Hz).

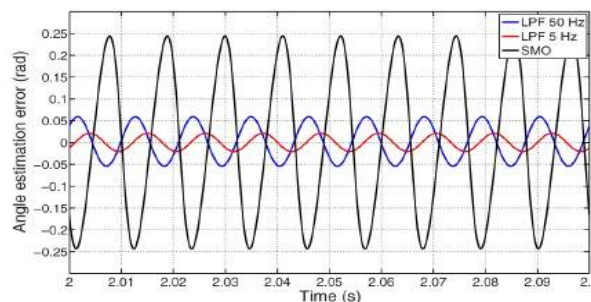

Fig.12. Angle Estimation Error in the Presence of a 25% Amplitude Fifth Harmonic in the Back-EMF in Case of Narrow and Wide Low-Pass Filter of the Proposed Flux Estimator and in Case of SMO Analysis at 90 Rpm Cut- in Operating Point.

V. CONCLUSION

This paper described the global control of the active rectifier in a wind power system with modular architecture. The paper proposed an algorithm for the estimation of the rotor angle of the PMSG, based on flux estimators, which was implemented using an LPF coupled with a feed-forward compensator. The dynamic compensation allows for very good tracking performance even at low rotational speed. The control algorithm allows for a very smooth start-up of the PMSG, which is of paramount importance in microwind system to avoid an abrupt deceleration of the



ISSN (Print) : 2320 – 3765
ISSN (Online): 2278 – 8875

International Journal of Advanced Research in Electrical, Electronics and Instrumentation Engineering

(An ISO 3297: 2007 Certified Organization)

Website: www.ijareeie.com

Vol. 6, Issue 6, June 2017

turbine, especially in case of turbines with low-starting torque, such as VAWTs. FLC and its adaption laws improve the current source controller to achieve the high smooth strategy of control the line frequency transformer together with the LC filter for eliminating the high frequency harmonics comes from the high frequency switching pattern of PWM. The grid side maximum power amount is delivered to the load with the high efficiency. Simulation and experimental results confirmed the effectiveness of the proposed solutions. The simulations highlighted that the proposed flux estimator possess excellent angle-tracking performance under varying operating conditions, especially at start-up. Simulation results depict that grid current is in phase with voltage with the same frequency and unity power factor in time the wind turbine. integrates to the grid and so the maximum power amount is delivered to the load with the high efficiencies.

REFERENCES

- [1] T. Friedli, J. Kolar, J. Rodriguez, and P. Wheeler, "Comparative evaluation of three-phase ac-ac matrix converter and voltage dc-link back-to-back converter systems," *IEEE Trans. Ind. Electron.*, vol. 59, no. 12, pp. 4487–4510, Dec. 2012.
- [2] R. Portillo et al., "Modeling strategy for back-to-back three-level converters applied to high-power wind turbines," *IEEE Trans. Ind. Electron.*, vol. 53, no. 5, pp. 1483–1491, Oct. 2006.
- [3] Z. Chen, X. Xiao, H. Wang, and M. Liu, "Analysis of converter topological structure for direct-drive wind power system with PMSG," in *Proc. Int. Conf. Power Syst. Technol. (POWERCON'10)*, Oct. 2010, pp. 1–5.
- [4] D. Vilathgamuwa and S. Jayasinghe, "Rectifier systems for variable speed wind generation: A review," in *Proc. IEEE Int. Symp. Ind. Electron. (ISIE'12)*, May 2012, pp. 1058–1065.
- [5] C. Bianchini, F. Immovilli, E. Lorenzani, A. Bellini, and G. Buticchi, "Micro wind turbine system integration guidelines pmsg and inverter front end choices," in *Proc. 38th Annu. Conf. IEEE Ind. Electron. Soc. (IECON'12)*, Montreal, Canada, Oct. 2012, pp. 1073–1078.
- [6] S. Li, T. Haskew, R. Swatloski, and W. Gathings, "Optimal and directcurrent vector control of direct-driven pmsg wind turbines," *IEEE Trans. Power Electron.*, vol. 27, no. 5, pp. 2325–2337, May 2012.
- [7] K. Huang, S. Huang, F. She, B. Luo, and L. Cai, "A control strategy for direct-drive permanent-magnet wind- power generator using back-to-back pwm converter," in *Proc. Int. Conf. Elect. Mach. Syst. (ICEMS'08)*, Oct. 2008, pp. 2283–2288.
- [8] S. Cobreces, E. Bueno, F. Espinosa, F. Rodriguez, and C. Martin, "Contributions to the dc-bus voltage controller of back-to-back voltage source converters," in *Proc. 31st Annu. Conf. IEEE Ind. Electron. Soc. (IECON'05)*, Nov. 2005, p. 6 pp.
- [9] K.-H. Kim, Y.-C. Jeung, D.-C. Lee, and H.-G. Kim, "Robust control of pmsg wind turbine systems with back-to-back pwm converters," in *Proc. 2nd IEEE Int. Symp. Power Electron. Distrib. Gener. Syst. (PEDG'10)*, Jun. 2010, pp. 433–437.
- [10] P. Acarnley and J. Watson, "Review of position- sensorless operation of brushless permanent-magnet machines," *IEEE Trans. Ind. Electron.*, vol. 53, no. 2, pp. 352–362, Apr. 2006.