



ISSN (Print) : 2320 – 3765
ISSN (Online): 2278 – 8875

International Journal of Advanced Research in Electrical, Electronics and Instrumentation Engineering

(An ISO 3297: 2007 Certified Organization)

Website: www.ijareeie.com

Vol. 6, Issue 12, December 2017

Enhancement of Reconfiguration Problem Using Harmony Search Algorithm for Power Distribution System

K.K.S.V.V.Prakasa Rao, Dr.P.Hema Chandu, Dr.V.C.Veera Reddy,

Satish Dhawan Space Centre, Andhra Pradesh, India

Associate Prof. &HOD, Dept. of EEE, SVTM, MPL, India

Retd Professor, SV University, Tirupati, India

ABSTRACT: This paper introduces a new, fast, Harmony Search Algorithm (HSA) for the purpose of solving the DSR problem in normal operation by satisfying all objectives simultaneously with a relatively small number of generations and relatively short computation time. The objectives of the problem are to minimize real power losses and improve the voltage profile and load balancing index with minimum switching operations. Instead of generating several ranks from the non dominated set of solutions, this algorithm deals with only one rank; then the most suitable solution is chosen according to the operator's wishes. If there is no preference and all objectives have the same degree of importance, the best solution is determined by simply considering the sum of the normalized objective values. Also, a HSA operation is applied instead of a random one to speed up convergence. To test the algorithm, it was applied to widely studied test systems and a real one. The results show the efficiency of this algorithm as compared to other methods in terms of achieving all the goals simultaneously with reasonable population and generation sizes and without using a mutation rate, which is usually problem dependent.

KEYWORDS: Distribution system reconfiguration, graph theory, guided mutation, Harmony Search Algorithm (HSA).

I.INTRODUCTION

As distribution systems are growing large and being stretched too far, which leads to higher system losses and poor voltage regulation. This means that distribution systems are divided into subsystems of radial feeders, which contain a number of normally closed switches and a number of normally open switches. Due to uncertainty of system loads on different feeders, the loss minimum reconfiguration problem in the open loop radial distribution system is basically one of the complex combinatorial optimization; there is need for reconfiguration of the network from time to time. It is known that distribution network are built as interconnected harmonized networks, while in the process they are prearranged into a radial tree arrangement. Their configurations may be assorted with manual or automatic switching operations so that all the loads are supplied with electric power. This results in reduced power loss, increased system security and enhancement of power quality. The change in network configuration is performed by opening sectionalizing and closing tie switches of the network under normal and abnormal operating conditions. Reconfiguration also relieves the over loading of the network components but voltage profile will not be improved to the required level. In order to meet energy demand distributed generation devices can be strategically placed in power systems for grid reinforcement, reduction of power losses and on-peak operating costs, improvement of voltage profiles and also load factor of the system.



International Journal of Advanced Research in Electrical, Electronics and Instrumentation Engineering

(An ISO 3297: 2007 Certified Organization)

Website: www.ijareeie.com

Vol. 6, Issue 12, December 2017

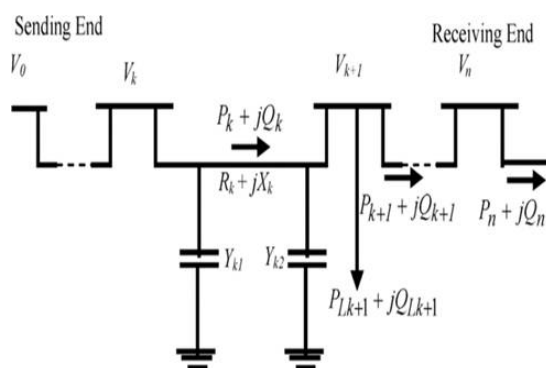

Fig. 1. Single-line diagram of a main feeder.

The authors R.Srinivasa Rao, S.V.L.Narasimham, M.R.Raju, and A.Srinivasa Rao presents a Harmony Search algorithm (HSA) was proposed to solve the network reconfiguration problem to get optimal switching combinations simultaneously in the network to minimize real power losses in the distribution network [1]. The proposed algorithm converges to optimum solution quickly with high accuracy. The size of the solution vector is equal to the total number of switches in the system. As the size of the system increases, the size of the solution vector in the other methods is large compared to the proposed method and computation time is also better than other methods.

II. FORMULATION OF OPTIMIZATION PROBLEM

A. Power Flow Equations

By applying efficient method [2], the load flow solutions in a distribution system are computed by the following set of simplified recursive equations derived from the single-line diagram shown in Fig.1:

$$P_{k+1} = P_k - P_{Loss,k} - P_{Lk+1}$$

$$= P_k - \frac{R_k}{|V_k|^2} \{P_k^2 + (Q_k + Y_k |V_k|^2)^2\} - P_{Lk+1} \quad (1)$$

$$Q_{k+1} = Q_k - Q_{Loss,k} - Q_{Lk+1}$$

$$= Q_k - \frac{X_k}{|V_k|^2} \{P_k^2 + (Q_k + Y_{k1} |V_k|^2)^2\} - Y_{k1} |V_k|^2 - Y_{k2} |V_{k+1}|^2 - Q_{Lk+1} \quad (2)$$

$$|V_{k+1}|^2 = |V_k|^2 + \frac{R_k^2 + X_k^2}{|V_k|^2} (P_k^2 + (Q_k + Y_k |V_k|^2)^2) - 2(R_k P_k + X_k (Q_k + Y_k |V_k|^2)). \quad (3)$$

The power loss in the line segment linking buses k and k+1 may be considered as,

$$P_{Loss}(k, k + 1) = R_k \cdot \frac{(P_k^2 + Q_k^2)}{|V_k|^2}. \quad (4)$$

By summing up the losses of all line sections of the feeder, the total power loss is given by,

$$P_{T, Loss} = \sum_{k=1}^n P_{Loss}(k, k + 1). \quad (5)$$

B. Power Loss Using Network Reconfiguration

The network reconfiguration plays a vital role in finding the radial operating structure in order to minimize the system power losses and at the same time maintaining operating constraints, such as voltage profile of the scheme, current transport capability of the feeder and radial structure of distribution system. After reconfiguration, the power loss in the line section with buses k and k+1 is calculated as follows



International Journal of Advanced Research in Electrical, Electronics and Instrumentation Engineering

(An ISO 3297: 2007 Certified Organization)

Website: www.ijareeie.com

Vol. 6, Issue 12, December 2017

$$P'_{Loss}(k, k + 1) = R_k \cdot \frac{(P_k^2 + Q_k^2)}{|V'_k|^2}. \quad (6)$$

The total real power loss of the all lines sections in n bus system ($P_{T, Loss}$) is calculated by adding up the losses of all line sections of the feeder, which is described as,

$$P'_{T, Loss} = \sum_{k=1}^n P'_{Loss}(k, k + 1). \quad (7)$$

C. Loss Reduction Using Network Reconfiguration

Net power loss reduction in the system is the variance of power loss before and after reconfiguration, that is equations (5) – (7) and is given by

$$\Delta P^R_{Loss} = \sum_{k=1}^n P_{T, Loss}(k, k + 1) - \sum_{k=1}^n P'_{T, Loss}(k, k + 1). \quad (8)$$

D. Objective Function of the Problem

The objective function of the problem is expressed to maximize the power loss reduction in distribution system while subjected to power balance constraints and power generation limit.

The bus voltage magnitudes are to be kept within acceptable operating limits throughout the optimization process, as follows, that means voltage constraints should be satisfied, as given below, subjected to

$$V_{min} \leq V_k \leq V_{max} \quad (9)$$

And feeder capability limits

$$|I_{k, k+1}| \leq |I_{k, k+1, max}| \quad (10)$$

Generator operator constraints

$$\sum_{k=1}^n P_{Gk} \leq \sum_{k=1}^n (P_k + P_{Loss, k}) \quad (11)$$

Where the lower bound of bus voltage limits is V_{min} and V_{max} is the upper bound of bus voltage limits.

Radial structure of the system

$$\begin{aligned} \det(A) &= 1 \text{ or } -1 \text{ (radial system)} \\ \det(A) &= 0 \text{ (not radial)} \end{aligned} \quad (12)$$

III. HARMONY SEARCH ALGORITHM

The harmony search algorithm (HSA) is a latest meta-heuristic population algorithm. The harmony search algorithm (HSA) is simple in concept from natural musical presentation processes [5], few in parameters and easy in implementation. It has been effectively applied to different computational optimization [6] problems such as structural design, water network design, dam scheduling, and various benchmark and real-world problems like traveling salesman problem [7].

The main steps of HS are as follows [5]:

- Step1) Initialize the quandary and algorithmic parameters.
- Step2) Initialize the harmony memory.
- Step 3) Improvise a new harmony.
- Step4) Update the harmony memory.
- Step5) Check the stopping criteria.

These steps are explained in below as follows,

Step1. Initialize the Problem and Algorithm Parameters

The common optimization difficulty is specified as follows:

$$\text{minimize } f(x) \text{ subject to } x_i \in X_i, \quad i = 1, 2, \dots, N$$



International Journal of Advanced Research in Electrical, Electronics and Instrumentation Engineering

(An ISO 3297: 2007 Certified Organization)

Website: www.ijareeie.com

Vol. 6, Issue 12, December 2017

where $f(x)$ is an objective function; x is the set of each decision variable x_i ; N is the number of decision variables; X_i is the set of the possible range of values for each decision variable, that is $Lx_i \leq X_i \leq Ux_i$; and Lx_i and Ux_i are the lower and upper bounds for each decision changeable. The HS algorithmic parameters are also particular in this step. These parameters are harmony memory size (HMS), harmony memory considering rate (HMCR), pitch adjusting rate (PAR), number of improvisation (NI), and harmony memory (HM), which are defined in further steps.

Step 2. Initialize the Harmony Memory

In this step, the harmony memory (HM matrix) is filled with as many randomly generated solution vectors as HMS and sorted by the values of the objective function.

$$HM = \begin{bmatrix} x_1^1 & x_2^1 & \dots & x_{N-1}^1 & x_N^1 \\ x_1^2 & x_2^2 & \dots & x_{N-1}^2 & x_N^2 \\ \vdots & \vdots & \ddots & \vdots & \vdots \\ x_1^{HMS-1} & x_2^{HMS-1} & \dots & x_{N-1}^{HMS-1} & x_N^{HMS-1} \\ x_1^{HMS} & x_2^{HMS} & \dots & x_{N-1}^{HMS} & x_N^{HMS} \end{bmatrix}$$

Step 3. Improve a New Harmony

A New Harmony vector $x^{-'} = (x'_1, x'_2, \dots, x'_N)$ is generated from the HM based on memory considerations, pitch adaptations, and randomisation. For illustration, the rate of the first decision changeable for the new vector can be chosen from any value in the specified HM range. Values of the other decision variables can be chosen in the same manner known as improvisation. There is a possibility that the new value can be chosen using the HMCR constraint, which vary among 0 and 1 as follows:

$$x'_i = \begin{cases} x_i \in \{x_i^1, x_i^2, \dots, x_i^{HMS}\} & \text{with probability HMCR} \\ x_i \in X_i & \text{with probability}(1 - \text{HMCR}) \end{cases}$$

The HMCR sets the rate of choosing one value from the historic values stored in the HM and (1-HMCR) sets the rate of randomly choosing one feasible value not limited to those stored in the HM. For example, a HMCR of 0.9 indicates that the HS algorithm will choose the decision variable value from historically stored values in the HM with the 90% probability or from the entire possible range with the 10% probability. Each component of the New Harmony vector is examined to determine whether it should be pitch attuned. This process uses the PAR constraint that sets the rate of adjustment for the pitch chosen from the HM as follows: Pitch adjusting decision for

$$x'_i = \begin{cases} \text{with probability HMCR} \\ \text{with probability}(1 - \text{HMCR}) \end{cases}$$

A PAR of 0.3 indicates that the algorithm will choose a neighboring value with $30\% \times \text{HMCR}$ probability.

$$\begin{aligned} & \text{if } (rand() < \text{HMCR}) \\ & x'_i \leftarrow x_i \in \{x_i^1, x_i^2, \dots, x_i^{HMS}\} \\ & \text{else if } (rand() < \text{PAR}) \\ & x'_i = x_i \pm rand()b\omega \end{aligned}$$

Where $b\omega$ is an arbitrary distance bandwidth for the continuous design variable and $rand()$ is uniform distribution among 0 and 1. Since the quandary is distinct in scenery, is taken as 1.

Step 4. Update Harmony Memory

In this stage, if the New Harmony vector $x^{-'} = (x'_1, x'_2, \dots, x'_N)$ is better than the worst harmony vector in the HM in terms of the objective function value, the existing worst harmony is replaced by the New Harmony.



International Journal of Advanced Research in Electrical, Electronics and Instrumentation Engineering

(An ISO 3297: 2007 Certified Organization)

Website: www.ijareeie.com

Vol. 6, Issue 12, December 2017

Step 5. Check stopping criterion

Repeat steps 3 and 4 until the termination criterion is satisfied. The termination criterion: The computations are terminated when the termination criterion (maximum number of improvisations) is satisfied. Otherwise, steps 3 (improvising New Harmony from the HM) and 4 (updating the HM) are repeated.

IV. SIMULATION RESULTS

The proposed algorithm was programmed using MATLAB7.12 and implemented on a 1.64-GHz Notebook PC with 4 GB of RAM. It was applied to two widely-studied test systems, a 16-bus system and a 33-bus system. In order to test the convergence performance of the HSA, it was applied 100 times to each system and the most repeated solution set (the mode) was selected as the actual or representative solution set. The mode set represented 92% of all solution sets for the 33-bus system, and each chromosome was evaluated according to (3)–(6) using a Newton-Raphson based load flow program. The results are presented in the following and compared with results from other work.

33-Buses Test System

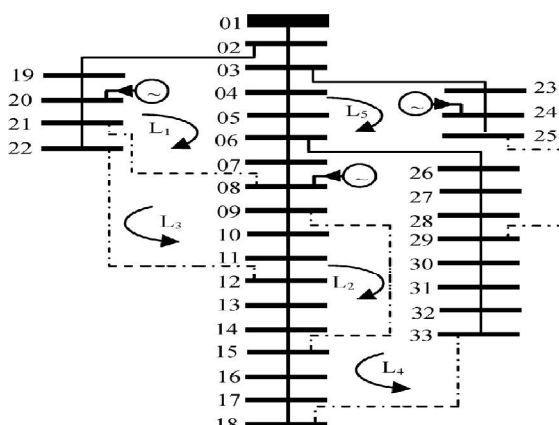

Fig. 2. 33-bus radial distribution system

The system data is given in [8]. As shown in Fig. 2, the system consists of 33 nodes, 37 branches, and five fundamental loops. The base MVA and kV are 10 and 12.66, respectively, and the total system loads are 3715 kW and 2300 kVAR. Initially, branches 33, 34, 35, 36, and 37 are open, as shown in Fig. 2, and the total system power loss is 224.93 kW. The new HAS produced a set of 34 nondominated solutions. Only the optimum topologies (from that set) according to the four objective functions are listed in Table I. The results shown in Table I were obtained after ten generations and with an initial population of 30 chromosomes, and it required 20.2 s of CPU time.

If all objectives are of equal importance, the optimum solution is determined using (12) and (13) and the smallest sum of normalized objectives procedure described above. That would make Solution 10, in the fifth row of Table I, with a summation value of 0.748, the optimum solution, as compared to four other methods, all of which satisfied only the power loss objective with nearly the same value.



International Journal of Advanced Research in Electrical, Electronics and Instrumentation Engineering

(An ISO 3297: 2007 Certified Organization)

Website: www.ijareeie.com

Vol. 6, Issue 12, December 2017

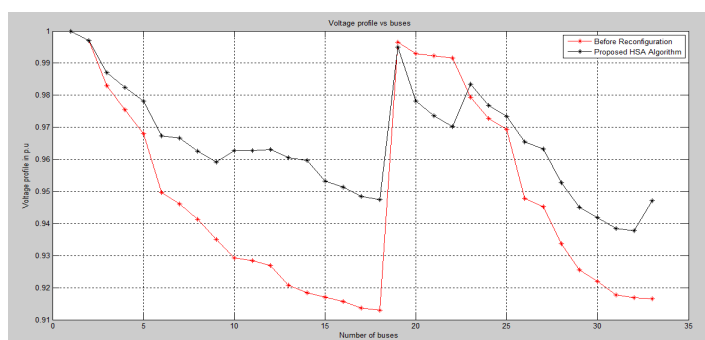

Fig 3. Voltage profile of the IEEE 33 bus System with & without Harmony Search Algorithm (HSA)

TABLE I
OPTIMUM SOLUTIONS OF THE FOUR OBJECTIVES RESULTING FROM THE APPLICATION OF FNSGA TO THE 33-BUS SYSTEM

Methods	Power Losses In KW	Reactive Power Losses in Kvar	Minimum Voltage in pu	Loss Improvement in %
Base Case	202.7	135.24	0.9130	0
HSA	139.55	102.39	0.9378	31.1544

V. CONCLUSION

A novel algorithm has been offered to solve the network reconfiguration problem for minimizing the active power losses. Proficient Meta heuristic HSA is used in the optimization procedure of the network reconfiguration. The proposed method is tested on an IEEE 33-bus test system at different load extents, low, normal and high. The result shows that network reconfiguration method is more proficient in decreasing power loss and improving the voltage profile compared to other methods. In previous approaches, system reconfiguration in distribution networks are considered separately. However, in the proposed method network reconfiguration deal concurrently for better loss minimization and voltage summary.

REFERENCES

- [1] A. A. Zin, A. Ferdavani, A. Khairuddin, and M. Naeini, "Two circularupdating hybrid heuristic methods for minimum-loss reconfiguration of electrical distribution network," *IEEE Trans. Power Syst.*, vol. 28, no. 2, pp. 1318–1323, May 2013.
- [2] T. Thakur and Jaswanti, "Study and characterization of power distribution network reconfiguration," in *Proc. 2006 IEEE Power and Energy Society Transmission and Distribution Conf.*, pp. 1–6.
- [3] D. Shirmohammadi and H. Wayne Hong, "Reconfiguration of electric distribution networks for resistive losses reduction," *IEEE Trans. Power Del.*, vol. 4, no. 2, pp. 1492–1498, Apr. 1989.
- [4] S. Civanlar, J. J. Grainger, H. Yin, and S. S. H. Lee, "Distribution feeder reconfiguration for loss reduction," *IEEE Trans. Power Del.*, vol. 3, no. 3, pp. 1217–1223, Jul. 1988.
- [5] M. E. Baran and F. F. Wu, "Network reconfiguration in distribution systems for loss reduction and load balancing," *IEEE Trans. Power Del.*, vol. 4, no. 2, pp. 1401–1407, Apr. 1989.
- [6] T. P. Wagner, A. Y. Chikhani, and R. Hackam, "Feeder configuration for loss reduction: An application of distribution automation," *IEEE Trans. Power Del.*, vol. 6, no. 4, pp. 1922–1931, Oct. 1991.



ISSN (Print) : 2320 – 3765
ISSN (Online): 2278 – 8875

International Journal of Advanced Research in Electrical, Electronics and Instrumentation Engineering

(An ISO 3297: 2007 Certified Organization)

Website: www.ijareeie.com

Vol. 6, Issue 12, December 2017

- [7] S. K. Goswami and S. K. Basu, "A new algorithm for the reconfiguration of distribution feeders for loss minimization," *IEEE Trans. Power Del.*, vol. 7, no. 3, pp. 1484–1491, Jul. 1992.
- [8] T. E. McDermott, I. Drezga, and R. P. Broadwater, "A heuristic nonlinear constructive method for distribution system reconfiguration," *IEEE Trans. Power Syst.*, vol. 14, no. 2, pp. 478–483, May 1999.
- [9] W. M. Lin and H. C. Chin, "A new approach for distribution feeder reconfiguration for loss reduction and service restoration," *IEEE Trans. Power Del.*, vol. 13, no. 3, pp. 870–875, Jul. 1998.
- [10] M. A. Kashem, G. B. Jasmon, A. Mohamed, and M. Moghavvemi, "Artificial neural network approach to network reconfiguration for loss minimization in distribution networks," *Int. J. Elect. Power Energy Syst.*, vol. 20, no. 4, pp. 247–258, May 1998.
- [11] A. Augugliaro, L. Dusonchet, M. G. Ippolito, and E. R. Sanseverino, "Minimum losses reconfiguration of MV distribution networks through local control of tie-switches," *IEEE Trans. Power Del.*, vol. 18, no. 3, pp. 762–771, Jul. 2003.
- [12] K. Nara, Y. Mishima, A. Gjyo, T. Ito, and H. Kaneda, "Loss minimum reconfiguration of distribution system by tabu search," in *Proc. 2002 IEEE Conf. Transmission and Distribution, Asia*, pp. 232–236.
- [13] Y. Jeon and J. Kim, "Network reconfiguration in radial distribution system using simulated annealing and tabu search," in *Proc. 2000 IEEE Power Engineering Society Winter Meeting*, pp. 2329–2333.
- [14] A. Skoonpong and S. Sirisumrannukul, "Network reconfiguration for reliability worth enhancement in distribution systems by simulated annealing," in *Proc. 2008 IEEE Int. Conf. Electronics, Computer Telecommunications, and Information*, pp. 937–940.
- [15] K. H. Jung, H. Kim, and Y. Ko, "Network reconfiguration algorithm for automated distribution systems based on artificial intelligence approach," *IEEE Trans. Power Del.*, vol. 8, no. 4, pp. 1933–1941, Oct. 1993.
- [16] S. H. K. Vuppapapati and A. K. Srivastava, "Application of ant colony optimization for reconfiguration of shipboard power system," *Int. J. Eng., Sci., Technol. (IJEST)*, vol. 2, no. 3, pp. 119–131, 2010.
- [17] A. Ahuja, S. Das, and A. Pahwa, "An AIS-ACO hybrid approach for multi-objective distribution system reconfiguration," *IEEE Trans. Power Syst.*, vol. 22, no. 3, pp. 1101–1111, Aug. 2007.
- [18] Y. T. Hsiao, "Multi-objective evolution programming method for feeder reconfiguration," *IEEE Trans. Power Syst.*, vol. 19, no. 1, pp. 594–599, Feb. 2004.
- [19] M. Assadian, M. M. Farsangi, and H. Nezamabadi-Pour, "Optimal reconfiguration of distribution system by PSO and GA using graph theory," in *Proc. 6th WSEAS Int. Conf.*, Istanbul, Turkey, May 2007, pp. 83–88.