



Design of PSS to Damped out the Inter-Area Oscillations from Power System under Small Disturbance

Ishteyaque Ahmad¹, Prabodh Khampariya²

PG Student [Electrical Power System], Dept. of Electrical Engineering, SSSUTMS, Sehore, Madhya Pradesh, India¹

Associate professor, Dept. of Electrical Engineering, SSSUTMS, Sehore, Madhya Pradesh, India²

ABSTRACT: In this paper, design a Power System Stabilizer (PSS) to damp out an inter-area oscillations based on two different approaches: Residue approach and Geometric approach. Simulations and different results on Kundur's two-area four-machine shows that in the case of wide-area signal selection, the geometric approach is more reliable and useful the residue approach. Also, the result conform that wide-area damping control scheme is more effective than local control for damping of inter-area oscillation.

KEYWORDS:Residue Approach, Geometric Approach, Power System Stabilizer (PSS), Inter-area oscillations,

I.INTRODUCTION

The continuous inter-connection of regional electric grid is the developing trend of modern power system in India and rest of the world. The main reason for interconnection of electric grids is that it can efficiently utilize various power resources distributed in different areas and achieve the optimal allocation of energy resources. This also optimizes the economic dispatch of power and gets relatively cheaper power, which implies that decrease of system installed capacity and the investment. Moreover, in case of fault or disturbance in operating condition, it can also provide additional supporting power of each area of interconnected grids which can increase the reliability of generation, transmission and distribution system.

With the growing electricity demand and the aging utility infrastructure, the present-day power systems are operating close to their maximum transmission capacity and stability limit. In the past few decades, the angular instability, caused by small signal oscillations, has been observed in the power systems under certain system conditions, such as during the transmission of a large amount of power over long distance through relatively weak tie lines and under use of high gain exciter. These conditions introduce inter-area oscillations [0.1-1.0 Hz][1] in the power system and which may cause a black out of the whole power system.

The inter area oscillations inherent to the large inter connected grid becomes more dangerous to the system's security and the quality of the supply during transient situation. Hence it can be said that the low frequency oscillations put limitations on operation of the power system and network's control security. The increased interconnected network of power system carries out heavy inter change of electrical energy which invokes such poorly damped low frequency oscillation that the system stability becomes major concern. The following are some example where large disturbances in power system network tends to produce low frequency inter area oscillations in the grid through the world [2]

- Detroit Edison (DE-Ortario Hydro-Hydro Quebec-1960s, 1985s)
- Finland-Sweden-Norway-Denmark (1960s)
- Western Electric Coordinating Council (1964,1996)
- South East Australia (1975)
- Scotland-England (1978)
- Western Australia (1982, 1983)



ISSN (Print) : 2320 – 3765
ISSN (Online): 2278 – 8875

International Journal of Advanced Research in Electrical, Electronics and Instrumentation Engineering

(An UGC Approved Journal)

Website: www.ijareeie.com

Vol. 6, Issue 8, August 2017

- Ghana-Ivory Coast (1985)
- Southern Brazil (1975,1984)
- India (2012)

The heavy power transfer needs either new lines to be added or need high voltage compensation such as series compensation to damp low frequency inter area oscillations. However there are lot of restrictions like environmental factors, cost factors etc. in expansion of new lines and installation of compensation devices. Therefore in order to achieve the maximum transfer capacity of the power system and to maintain better system security, improvement in damping of electromechanical oscillations become more important.

The traditional approach to damp out the inter-area oscillations by using Conventional Power System Stabilizer (CPSS). The basic function of PSS is to add damping to the generator rotor oscillation by controlling its excitation using auxiliary stabilizing signal. These controllers use local signals as an input signal and may not always be able to damp out inert-area oscillations, main cause behind this, the design of CPSS based on system components linearization around one operating point. Also local controller have not global observation and may does not be effectively damped out the inter-area oscillation[3]

It is observed that the remote signals from different locations of power system are more effective to damp inter area oscillations[4]. The effective damping mechanism is that the damping torque of synchronous generator is enhanced through proper field excitation. The application of remote signal for damping controller has become successful due to the recent development of Phasor Measurement Units (PMUs). PMUs have very useful contribution in newly developed Wide Area Measurement System (WAMS) technology. The initial development of PMU based WAMS was introduced by Electric Power Research of Institute (EPRI) in 1990. The real time information of synchronous phasor and sending the control signal to major control device (e.g. PSSs, HVDC controllers, FACTS based controllers) at high speed have now become easier due to the use [5]

The PMU can provide wide area measurement signals. The signals can be used to enhance the wide area damping characteristics of a power system. The global signals or wide area measurement signal are then sent to the controllers through communication channel. It is found that if remote signals comes from one or more distant location of power system are used as a controller input then, the system dynamics performance can be improved in terms of better damping of inter-area oscillation.

The signals obtained from PMUs or remote signals contain information about overall network dynamics whereas local control signals has lack adequate observability with regard to some of the significant inter-area mode.

The wide area signals or the global signals are nothing but the remote stabilizing signals or the global signals. For the local mode of oscillations the most controllable and observable signals are the local signals. Such as generator speed deviation. But for inter area modes the local signals may not have maximum observability to damp these modes. Rather this can be effectively damped by the use of remote signals from a distant location or combination of several locations. Another important advantage of use of wide area signals is that it needs very small gain for the controller compared to the local controllers in order to achieve the same amount of damping. [6]

The most important task to design the wide area damping control is to select the most effective wide area signals. The basic criteria for selection of the signal are to have good observability and controllability of the signal for the system's inter area mode. So the signal which allows maximum observability and controllability of system's mode has to be selected as the most effective stabilizing signal for the controllers.

In this paper, the two different approaches are applied to the Kundur's two area four machines system in order to select the most effective signals to damp out the inter-area oscillations.

This paper is structured as follows: Section 2 presents the architecture of wide-area damping control system; Section 3 briefly discusses signals selection approaches. Signal selection and control location site for controller, based on

International Journal of Advanced Research in Electrical, Electronics and Instrumentation Engineering

(An UGC Approved Journal)

Website: www.ijareeie.com

Vol. 6, Issue 8, August 2017

geometric measure of joint controllability /observability and residue approach has been described in Section 4 while the Section 5 describe design of power system stabilizer Section-6 Simulation results and discussions and finally the conclusion is presented in section 7.

II. WIDE-AREA DAMPING CONTROLLER DESIGN STRUCTURE

For the designing of damping controller, decentralized and centralized structure is mostly used. In decentralized structure, there is no need of additional telecommunication equipment because it uses local signal as a control signal and also in this, all generators have local controller which increases the cost of the system. As days go by, more and more electrical networks are interconnected, as a result electrical networks are highly stressed. Decentralized or say local control alone may not be enough to fulfil the damping needs of future electrical networks [7]. Centralized wide area damping control provides more efficient solution due to the availability of large amount of system wide dynamic data and better observation of inter area mode. Wide area controls include any control that requires some communication link to either gather the input or to send out the control signal [8]. If remote signals are applied to the controller, then it is found that, system dynamic performance can be enhanced with respect to inter area oscillation[9], for this an additional telecommunication equipment is required for the realization of centralized wide area control system, still it is cost effective as compared to installing a new control device.

In a power system local oscillation modes are well damped out due to installation of local PSSs, but inter area modes are lightly damped out because of less observability of some significant inter area mode. A centralized controller structure is shown in Fig.1. In the wide area damping control system selected stabilizing signals are measured by PMUs and send through dedicated communication links to the controller. This signal is modulated and sent them to selected generator exciters.

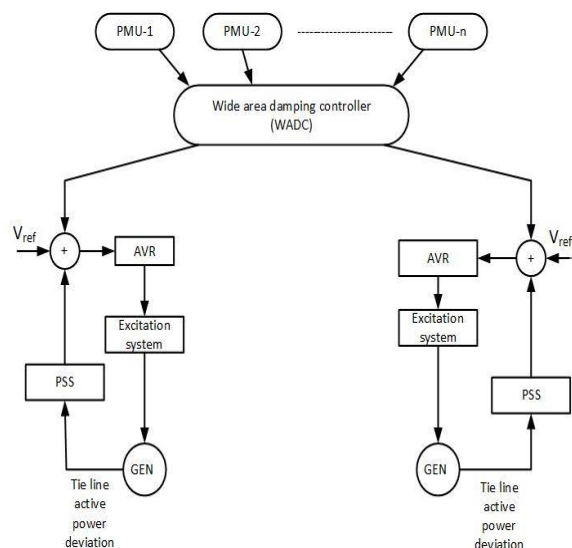

Fig. 1 General structure of wide area damping controller

III. SIGNAL SELECTION

Let us consider the identified linear model of network given by equation (1)

$$\begin{aligned} \dot{x} &= Ax + Bu \\ y &= Cx \end{aligned} \tag{1}$$



International Journal of Advanced Research in Electrical, Electronics and Instrumentation Engineering

(An UGC Approved Journal)

Website: www.ijareeie.com

Vol. 6, Issue 8, August 2017

Where $x \in R^{n \times n}$, $u \in R^{n \times m}$ and $y \in R^{p \times n}$ are the state, inputs and output vectors respectively. $A \in R^{n \times n}$, $B \in R^{n \times m}$ and $C \in R^{p \times n}$ are state, input and output matrices, respectively.

An eigen analysis of matrix A produces the distinct eigenvalues λ_i ($i = 1, 2, 3, \dots, n$) and corresponding matrices of right and left eigenvectors ϕ and ψ , respectively.

Modal analysis of linear model (1) is applied to find out the low-frequency oscillation modes and then identify the critical inter-area mode. Modal observability have been used to select a suitable feedback signal for WADC, such as residue measures [10] and geometric measures [11]

A) Geometric Approach

The geometric measure of controllability $gm_{ci}(k)$ and observability $gm_{oj}(k)$ associated with the mode k^{th} are given by [11]:

$$gm_{ci}(k) = \cos(\alpha(\psi_k, b_i)) = \frac{|\psi_k b_i|}{\|\psi_k\| \|b_i\|} \quad (2)$$

$$gm_{oj}(k) = \cos(\theta(\phi_k, c_j^T)) = \frac{|c_j \phi_k|}{\|\phi_k\| \|c_j\|} \quad (3)$$

In (3) and (4), b_i is the i^{th} column of matrix B corresponding to i^{th} input, c_j is the j^{th} row of output matrix C corresponding to j^{th} output. $|z|$ and $\|z\|$ is the modulus and Euclidean norm of z respectively. $\alpha(\psi_k, b_i)$ is geometrical angle between input vector i and k^{th} left eigenvector and $\theta(\phi_k, c_j^T)$ geometric angle between the output vector j and k^{th} right eigenvector. The joint controllability and observability index of geometric approach is defined by:

$$C = gm_{ci}(k) * gm_{oj}(k) \quad (4)$$

In the geometric approach it can prove that the higher the value of joint controllability and observability index more the stability of signal selected.

B) Residues Approach

The transfer function of an interconnected power system associated with the state equations (1) can be expressed by:

$$G(s) = C(sI - A)^{-1} = \sum_{i=1}^n \frac{R_i}{(s - \lambda_i)} \quad (5)$$

where R_i is known as residue matrix of size $q \times p$ associated with λ_i .

$$R_i = C \phi_i \psi_i B \quad (6)$$

For $j = 1, 2, \dots, q$ and $k = 1, 2, \dots, p$ the elements of the residue matrix R_i can be expressed as

$$R_i(j, k) = C_j \phi_i \psi_i B_k \quad (7)$$

In fact the residue can be represented as the product of the mode's controllability and observability. The controllability for the mode i at k^{th} generator can be represented as

$$cont_{j,k} = |\psi_i B_k| \quad (5)$$

The observability of the mode i from j^{th} output is defined by

$$obj_{j,k} = |C_j \phi_i| \quad (6)$$

From eq. (4), (5) and (6) it is concluded that

International Journal of Advanced Research in Electrical, Electronics and Instrumentation Engineering

(An UGC Approved Journal)

Website: www.ijareeie.com

Vol. 6, Issue 8, August 2017

$$|R_i| = |C_j \phi_i \psi_i B_k| = \text{obj}_{j,k} * \text{cont}_{j,k} \quad (7)$$

In[13] it has been proved that the PSS is installed at that generator where largest residue for the i^{th} mode is found.

IV.SIGNAL SELECTION AND CONTROL LOCATION SITE

In development of WADC model, each generator of proposed model has 11 state variables. Therefore, as per Kundur two area four machines model adapted in this research and the total order of the non-linear system has 44 state variables. After linearizing the non-linear test system about stable operating point of tie line active power whose initial value is 413 MW, the small signal analysis was undertaken using the PST. This resulted in two critical inter-area oscillations modes characterized by their damping ratio and frequency which are tabulated in Table-I.

Table-I Inter-Area Mode of Oscillation of Two Area Four Machines System

Mode No.	Eigen Value	Damping Ratio	Frequency (Hz)
5	$-0.25 \pm 6.5i$	0.36	0.1
15	$0.05 \pm 4.1i$	-0.01	0.65

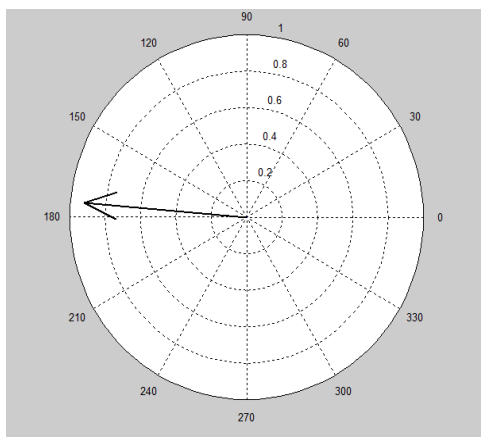

(Mode-5)

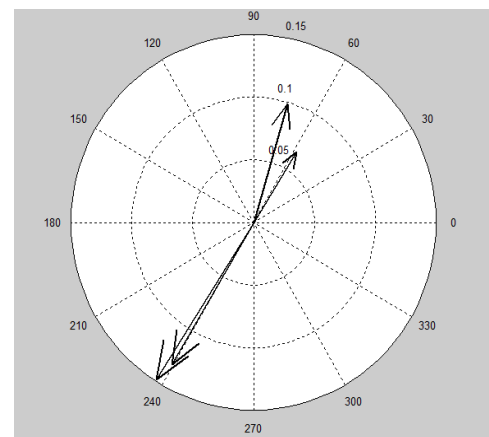

(Mode-15)

Fig. 2 Compass plots for Coherent Group Identification for Mode-5 and Mode-15

The compass plot of rotor angle state of mode - 5 and mode - 15 is obtained from participation factor analysis and shown in Fig - 2. For mode -5, Fig -2 (a) shows a single arrow, but actually there are four arrows of representing four generators with the same magnitude and direction superimposed one over the other, so they form only one area. For mode -15, Fig-2 (b) Gen-1 and Gen-2 form area-1 and Gen-3 and Gen-4 form area-2 and they are oscillating with respect to each other. So, mode -15 is considered for further analysis of feedback signal selection and control device location.

The most stabilizing feedback signal selection was evaluated by both residue approach and geometric measure of controllability/observability approach as explained in Section-III. The candidate signals that are considered for the selection process are line active power, generator rotor speeds and bus voltage angle.

Table-II shows the residue for signals and control location site. The highest residues shown bold in Table-II, suggest that the given inter area mode is efficiently controllable from Gen-2 and Gen-4 and are well observable from line active



International Journal of Advanced Research in Electrical, Electronics and Instrumentation Engineering

(An UGC Approved Journal)

Website: www.ijareeie.com

Vol. 6, Issue 8, August 2017

power flow of the transmission line connecting bus no. 9 to 10. Hence the line active power between bus no. 9 to 10 taken as a feedback signal for the controller.

Table-II Signal Selection and Control location for Mode-15 ($0.05 \pm 4.1i$)

Signals	Generators			
	G-1	G-2	G-3	G-4
P ₇₋₆	0.4278	0.5631	0.4536	0.6075
P ₇₋₈	0.3136	0.4128	0.3325	0.4454
P ₇₋₈	0.3136	0.4128	0.3325	0.4454
P ₅₋₆	0.2741	0.3608	0.2906	0.3892
P ₃₋₁₁	0.3910	0.5147	0.4146	0.5553
P ₄₋₁₀	0.3473	0.4572	0.3682	0.4932
P ₉₋₈	0.2853	0.3756	0.3025	0.4052
P ₉₋₈	0.2853	0.3756	0.3025	0.4052
P ₉₋₁₀	0.7042	0.9269	0.7466	1.000
P ₁₁₋₁₀	0.3910	0.5147	0.4146	0.5553
ω_1	0.0006	0.0008	0.0006	0.0009
ω_2	0.0004	0.0005	0.0004	0.0006
ω_3	0.0009	0.0012	0.0010	0.0013
ω_4	0.0008	0.0011	0.0009	0.0011
θ_7	0.0357	0.0470	0.0379	0.0507
θ_9	0.0461	0.0607	0.0489	0.0655
θ_8	0.0108	0.0142	0.0114	0.0153

Similarly the results achieved by geometric measure of joint controllability/observability are represented in Table-III. The highest joint controllability/observability indices are indicated in bold. The highest joint controllability/observability indices shown in Table-III suggest that the given inter area mode is efficiently controllable from Gen-2 and Gen-4 and are well observable from line active power flow of the tie-line connecting bus no. 7 to 8. Hence from geometric approach of signal selection the most stabilizing feedback signal is real tie-line power P₇₋₈ and most effective generators for damping the inter area mode are Gen-2 and Gen-4.

Table-III Geometric measure of controllability/observability approach for signal selection for mode-15 ($0.05 \pm 4.1i$)

Signals	Generators			
	G-1	G-2	G-3	G-4
P ₇₋₆	0.2726	0.3588	0.2890	0.3871
P ₇₋₈	0.7042	0.9269	0.7466	1
P ₅₋₆	0.1314	0.1730	0.1394	0.1867
P ₃₋₁₁	0.1878	0.2473	0.1991	0.2667
P ₄₋₁₀	0.1397	0.1839	0.1481	0.1984
P ₉₋₈	0.6988	0.9198	0.7409	0.9923
P ₉₋₁₀	0.3629	0.4777	0.3847	0.5153
P ₁₁₋₁₀	0.1878	0.2473	0.1991	0.2667
ω_1	0.0046	0.0060	0.0049	0.0065
ω_2	0.0031	0.0040	0.0033	0.0044
ω_3	0.0069	0.0091	0.0073	0.0098
ω_4	0.0061	0.0081	0.0065	0.0087
θ_7	0.3454	0.4565	0.3677	0.4925
θ_9	0.4684	0.6166	0.4966	0.6652
θ_8	0.1255	0.1653	0.1331	0.1783



International Journal of Advanced Research in Electrical, Electronics and Instrumentation Engineering

(An UGC Approved Journal)

Website: www.ijareeie.com

Vol. 6, Issue 8, August 2017

The results obtained in Table-II and Table-III are summarized in Table-IV

Table-IV Summary of Signal Selection

Method	Selected Signal	Control Location
Residue	Real Power of line connecting bus 9 to 10	Generator 2 & 4
Geometric controllability/Observability	Real power of line connecting bus 7 to 8	Generator 2 & 4

V. DESIGN OF PHASE COMPANSATION PART

In this paper researcher has been taken Kundur two area four machine system as a multi-machine system. To achieve the damping of one oscillation mode, the eigenvalue corresponding to that mode must be placed at the left-half of the complex plane. The block diagram of the CPSS is shown in the Fig-3. The stabilizer gain K_{STB} determine the amount of damping introduced by the PSS. The signal washout block is a high pass filter, with time constant T_w , which eliminates the low frequencies that are present in the speed signal and allows the PSS to respond only to speed changes. The phase compensation block is usually a single first order lead-leg transfer function or cascade of two first order transfer function used to compensate the phase lag between the excitation voltage and the electrical torque of the synchronous machine. The output is the stabilization voltage to connect to the V_{STAB} input of the excitation system block used to control the terminal voltage of the synchronous machine.

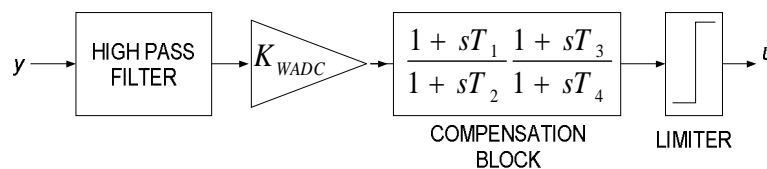

Fig-3 Conventional Power System Stabilizer

The different parameters for the CPSS in this paper are tabulated in Table-IV, based on Genetic Algorithm.

Table-IV Optimized Parameter for WADC

Parameters	Value
K_{WADC}	0.1
T_w	10 s
T_1	0.1 s
T_2	0.02 s
T_3	0.05 s
T_4	0.01 s
Limits	-0.15(Lower) 0.15 (Upper)

International Journal of Advanced Research in Electrical, Electronics and Instrumentation Engineering

(An UGC Approved Journal)

Website: www.ijareeie.com

Vol. 6, Issue 8, August 2017

Each selected generators are employed with a local PSS (LPSS) taking local control signal as input to the controller. The local controllers are fed by change in speed deviation as input to the LPSS. Local controllers are assumed to be employed with selected generator in order to damp localmode oscillations. There is a supplementary PSS fed by wide area signal, usually referred to as Global PSS (GPSS). The sum of both the signal is given to the input of AVR. The global area control scheme is given Fig-4.

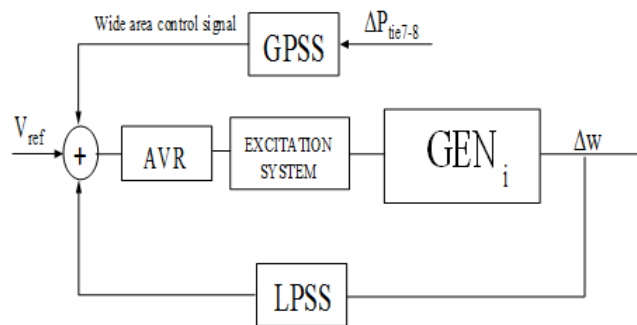

Fig. 4Global area control scheme.

VI. SIMULATION RESULTS AND COMPARISON

To perform the dynamic analysis of the closed loop test system for Kundur two area four machine system as shown in fig -5, a small pulse with magnitude of 5% as a disturbance was applied to the generator G1 for 12 cycles.

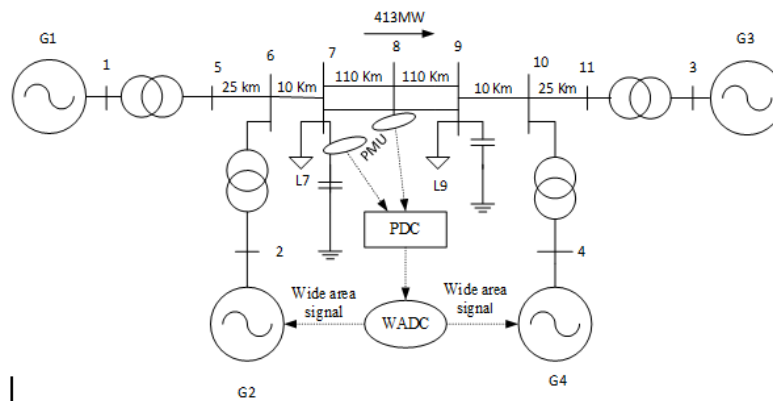

Fig-5Kundur's Two Area Four Machine System

The simulation time was of 20 seconds. Then the different responses has been observed in figure of tie-line active power flow from area-1 to area-2, rotor speed responses and positive sequence voltage at Bus-7 and Bus-9 respectively by considering the test system with GPSS and WPSS under the presence of selected feedback signals by both the residue and geometric approach.

Small Signal Stability and Assessment

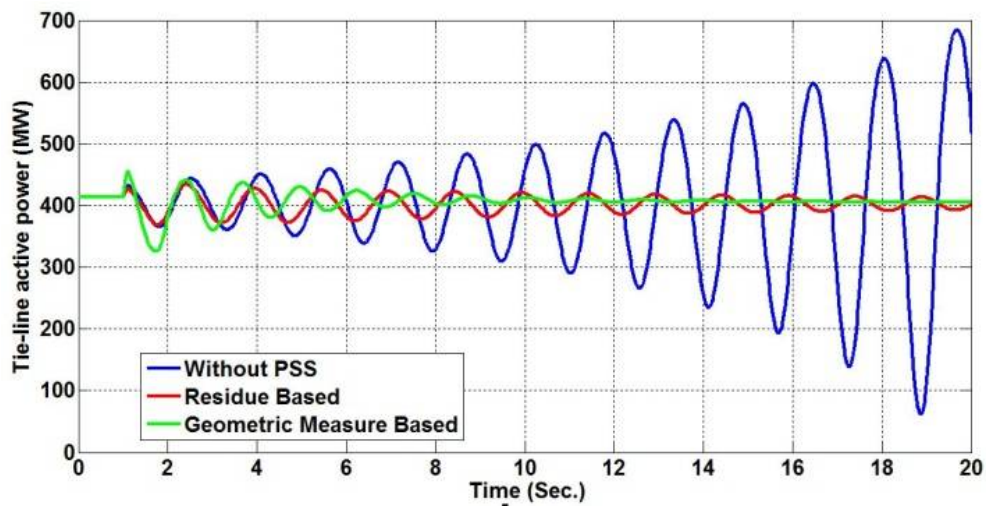

Fig. 6 Tie line active power flow deviation

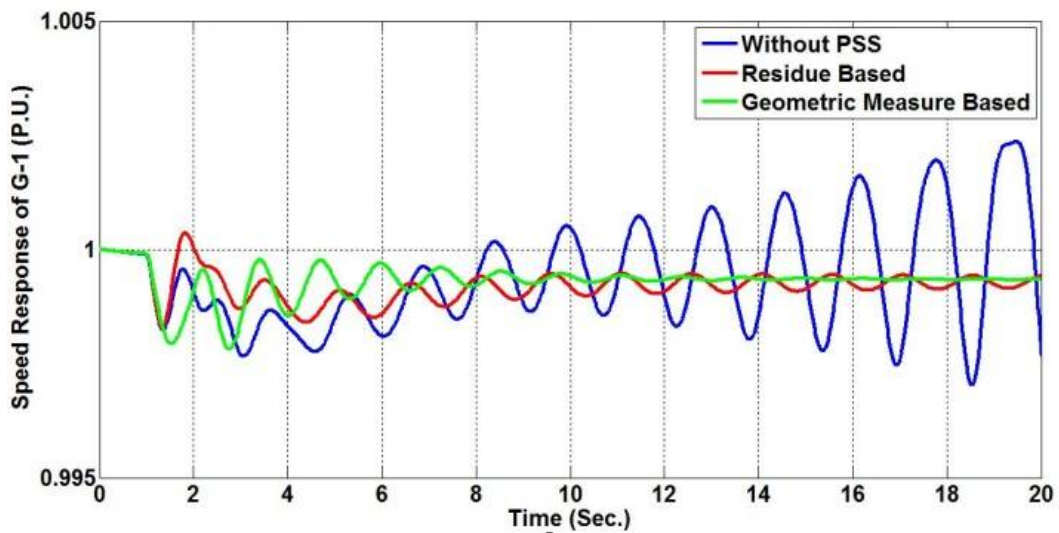

Fig. 7 Speed response of generator – 1

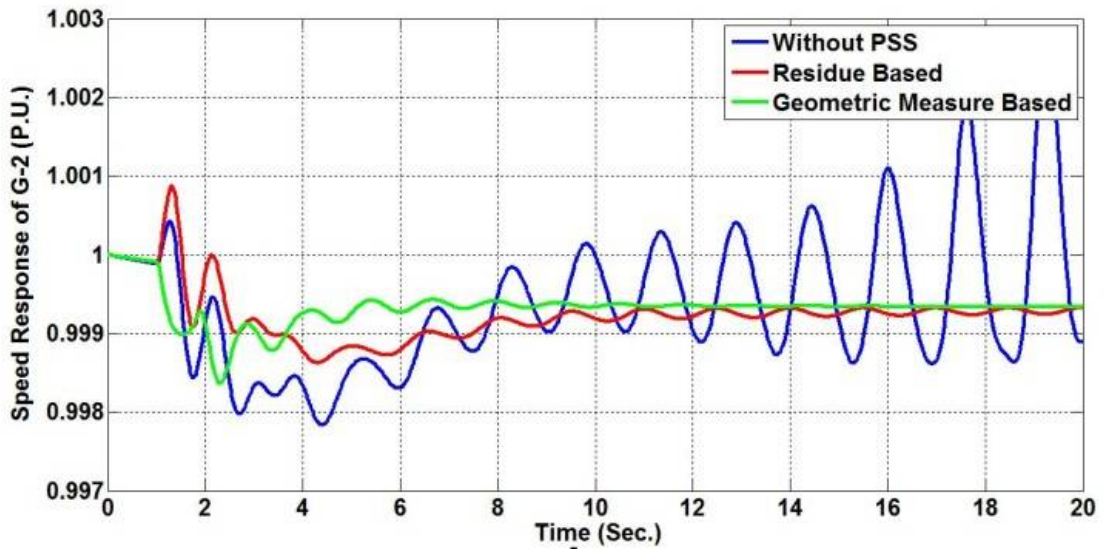

Fig. 8 Speed response of generator – 2

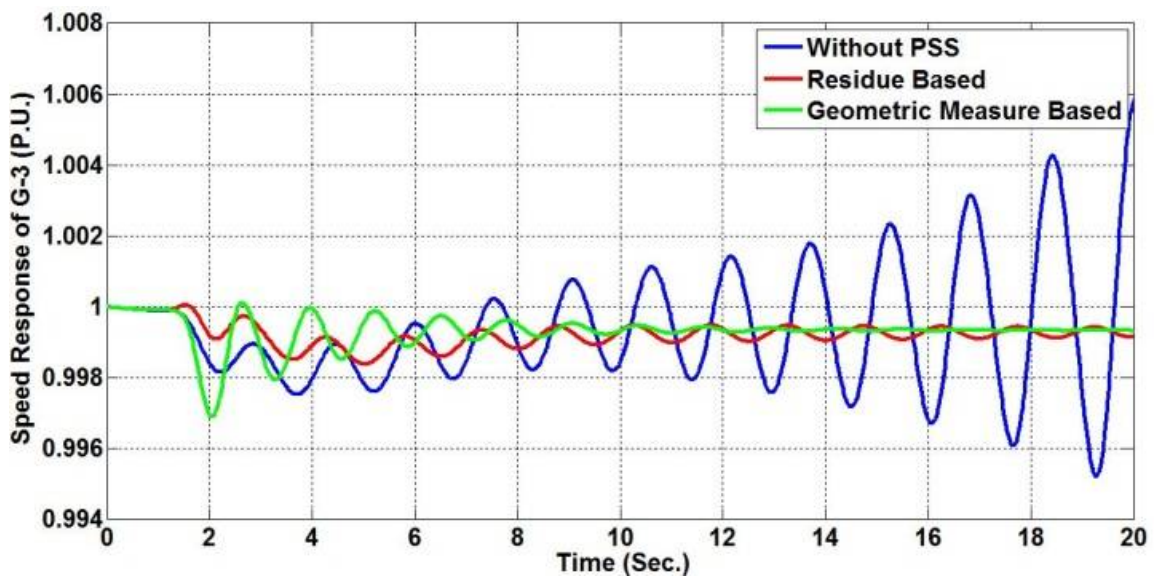

Fig. 9 Speed response of generator – 3

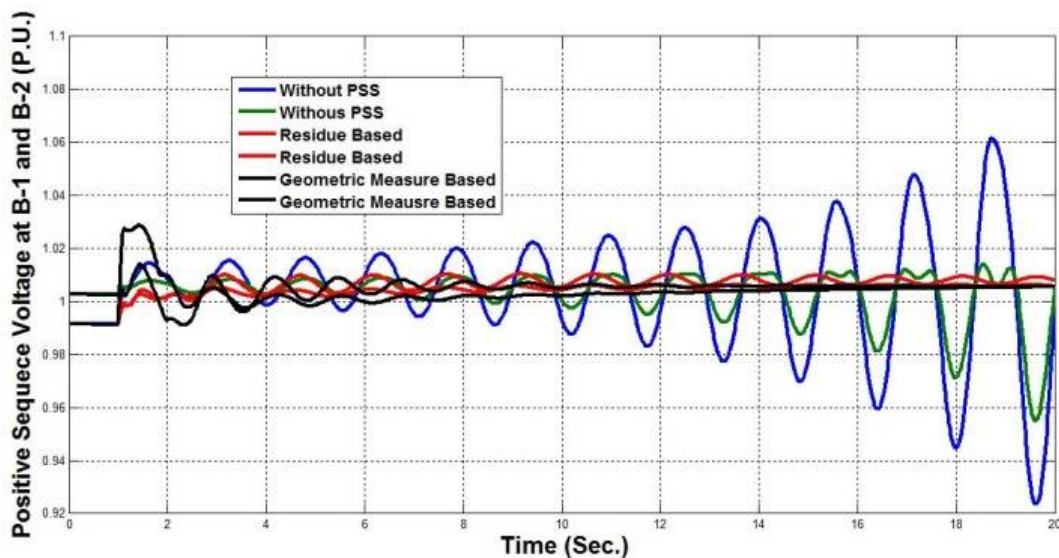

Fig. 10 Positive sequence voltage at Bus-1 and Bus-2

VII.CONCLUSION

The major work in this dissertation is to select the most suitable stabilizing feedback signal to the wide area controller. The selection of most suitable stabilizing feedback signal to the wide-area controller is the key objective of the controller design. In this dissertation two different methods of signal selection for wide area damping controller of power system have been exercised with emphasis on damping of critical inter area mode. The methods of signal selection discussed include approach based on residue and geometric measure of joint controllability/observability. The controller design and structure have been kept simple. The controller used in this dissertation is as simple as a two channel lead-lag compensator based Power System Stabilizer. The methods of signal selection were illustrated on Kundur's two area four machine systems. The effectiveness in damping of the critical inter area mode was assessed by both small disturbance.

In order to perform the small disturbance analysis a step change in reference voltage has been applied to the Generator no. 1. In this context the responses of the power system showed that the geometric measure of controllability/observability is the best method of signal selection among the two in case of small disturbance. In this context also the approach based on geometric measure of joint controllability/observability performed well in improving the stability of the power system as compared the approach based on residue method. Hence it can be concluded that the geometric measure of controllability/observability is the best one out of the two methods of signal selection.

REFERENCES

- [1] Kundur P, Paserba J, "Definition And Classification Of Power System Stability," IEEE Transactions On Power Systems, Vol. 19, No.2. May 2004, Pp. 1387-1401.
- [2] PalB.C. "Robust Damping Control Of Inter-Area Oscillations In Power System With Super-Conducting Magnetic Energy Storage Devices," Phd Thesis, Imperial College Of Science Technology And Medicine, Department Of Electrical & Electronics Engineering.
- [3] Panda Manoj Kumar; Pillai G.N.; and Kumar Vijay; - "Power System Stabilizer Design: Interval Type-2 Fuzzy Logic Controller Approach"- 2nd International Conference on Power, Control and Embedded Systems, Pub: IEEE, 2012.
- [4] Ugalde-Loo C. E, Acha E, Castro E. L, "Multi-Machine Power System State-Space Modelling for Small-Signal Stability Assessments," Elec. Power Syst. Res., vol. 37, Jan 2014, pp. 10141-10161.



ISSN (Print) : 2320 – 3765
ISSN (Online): 2278 – 8875

International Journal of Advanced Research in Electrical, Electronics and Instrumentation Engineering

(An UGC Approved Journal)

Website: www.ijareeie.com

Vol. 6, Issue 8, August 2017

- [5] Kundur P, "Power System Stability and Control," New York: McGraw-Hill, 1994.
- [6] Kamwa, L. GérinLajoie, "State-Space System Identification-Toward MIMO Models for Modal Analysis and Optimization of Bulk Power Systems," *IEEE Trans. on Power Systems*, vol. 15, no. 1, Feb. 2000, pp. 326-335
- [7] Kamwa, I. ; Hiniche, A.; Trudel, G.; Dobrescu, M.; Grondin, R.; and Lefebvre, D. – "Assessing the technical value of FACTS-based Wide-Area Damping Control Loops" – IEEE Power Eng. Soc. General Meeting, Vol. 2, June 2005, pp. 1734-1743
- [8] Tomsovic K.; BakkenD.E.; Venkatasubramanian V.; and Bose, A.; - "Designing the Next Generation of Real-Time Control, Communication and Computations for large Power Systems," – Proc. IEEE, Pub: IEEE, Vol. 93, No. 5, May 2005, pp. 965-979
- [9] Ela, Magdy E. Aboul; Sallam, A.A.; McCalley, James D.; and Found, A.A.; - "Damping Controller Design For Power System Oscillations," – IEEE Transaction on Power Systems, Pub: IEEE, Vol. 11, No. 2, May 1996, pp. 767-773
- [10] D. Dotta, A. S. Silva, and I. C. Decker, "Wide-area measurements based two-level control design considering signal transmission delay," *IEEE Trans. Power Syst.*, vol. 24, no. 1, pp. 208–216, Feb. 2009.
- [11] M. A. Hamdan and A.M. Elabdalla, "Geometric measures of modal controllability and observability of power system models," *Electr. Power Syst. Res.*, vol. 15, no. 2, pp. 147–155, Oct. 1988
- [12] Y. Zhang and A. Bose, "Design of wide-area damping controllers for interarea oscillations," *IEEE Trans. Power Syst.*, vol. 23, no. 3, pp. 1136–1143, Aug. 2008
- [13] Aboul-Ela, Sallam A, McCalley J, and Fouad A, "Damping Controller Design For Power System Oscillations Using Global Signals," *IEEE Trans. Power Syst.*, vol. 11, no. 2, May 1996, pp. 767–773