



Home Automation Using PLC

S.Sujatha¹, K.M.Om Prakash², M.Rajesh Kumar²

Professor and Head, Department of EIE, Adhiyamaan College of Engineering, Hosur, Tamil Nadu, India¹

UG Student, Department of EIE, Adhiyamaan College of Engineering, Hosur, Tamil Nadu, India²

ABSTRACT: With the rising power of technology, it is able to accomplish things at a much quicker rate. By simply at the touch of a button access to large amounts of information due to the capability of computers and the Internet. Not only has technology given us more information, but it also has given us the ability to communicate, organize, and manage our time. This paper gives the solution for controlling the home appliances with the less man power in a different way by using programming logical devices (PLC). The numerous benefits of today's home automation solution includes safety and security, energy savings, money savings, convenience and control. It improves the daily life of seniors and disabled by offering voice control and safety items.

KEYWORDS: Automating Devices, Programming Logic Device, Siemens Logo PLC

I. INTRODUCTION

The home automation has always been to make home more comfortable and secure, as well as to reduce the time spent managing a home by letting it do the work that a human would normally do, in essence making a home work for us. In addition to comfort and security, automating the home is the best way to regulate energy usage and reduce costs for heating, cooling and lighting. Home automation is taking centre stage in home technology circles for its ability to let home owners greatly reduce their energy consumption without changing their lifestyle, therefore helping them do their part to slow global warming, as well as saving them money. Home automation can be an exciting, new innovation that makes home appliances fun and easy to use for every member of the family. For example, a scenario such as I'm Home could be triggered by pressing one button from your vehicle as you approach the driveway. There were many papers presented before such as home automation using android application by remote control. It is used to design a home automation system with Android application that can be controlled remotely. This proposed system uses an Android OS based smart phone or tablet [9], upon a graphical user interface based touchscreen operation. In order to achieve this, Android application acts as a transmitter, which sends the ON/OFF commands to the receiver. The project is touch screen based home automation is to design a system with touch screen based control panel. In order to achieve this, a touch panel is interfaced to the microcontroller on the transmitter side which sends ON/OFF commands to the receiver where the loads are connected. In this paper, the controlling of the home devices without human intervention using PLC.

II. HOME AUTOMATION SYSTEM OVERVIEW

Though there were many products in the market for home automation. In order to overcome the weakness of those products and increase the efficiency and reduce cost. Control the devices with PLC software decreases the programming complexity and increasing the number of inputs. Using of logo PLC one of the advanced PLC technology can produce delays for more than month or year this might overcome the drawbacks of earlier models. The PLC technology will be Economical control of complex systems. It can be reapplied to control other systems easily and quickly. Sophisticated control can be done with computational abilities. Programming is easier and reduces downtime through troubleshooting ability. Reliability and durability of the components make PLCs likely to operate for years.

The control of the home based appliances such as water heater, airconditioner, exhaustfan, lightsetc. without human intervention as shown in Figure 1. For example, if the room is darker or insufficient light, the sensor senses it and commands the PLC to switch on the light. Similarly, if the smoke is detected, exhaust fan will be switched on. The Logo PLC can get four inputs and four outputs, the extensions could be made by connecting to main PLC. It has lithium ion battery, which provides power supply for 26 days. The water level in the tank will be maintain a level using a float switch, when the float switch goes to a particular lower level, the command goes to PLC and switches on the motor, when it goes to particular higher limit, it switches of the motor.

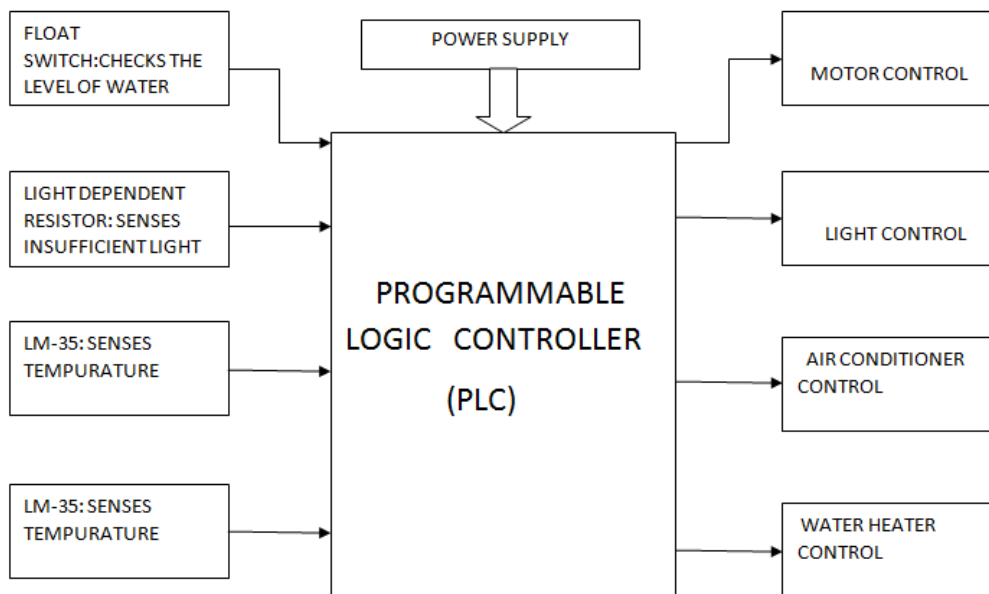

Figure 1. Block diagram home automation system

III. PROGRAMMING IN PLC

The most common method used for programming PLCs is based on the ladder diagrams. Writing a program is then equivalent or resembles to drawing a switching circuit. The ladder diagram consists of two vertical lines on either side representing the power rails which are positive and neutral. Circuits are connected in the rungs of the ladder which are horizontal, between these two rails. Ladder logic was originally a written method to document the design and construction of relay racks as used in manufacturing and process control. Each device in the relay rack would be represented by a symbol on the ladder diagram with connections between those devices shown. In addition, other items external to the relay rack such as pumps, heaters, and so forth would also be shown on the ladder diagram. Although the diagrams themselves have been used since the days when logic could only be implemented using switches and electromechanical relays, the term 'ladder logic' was only latterly adopted with the advent of solid state programmable logic.

Ladder logic acts as a programming language that represents a program in the form of graphical diagram based on the circuit diagrams of relay logic hardware and used in industrial control applications. The name Ladder Logic is appropriate as it resembles a ladder with two vertical rails on either side with a series of horizontally connected rungs between them. The system in the ladder diagram form will be programmed into the PLC. Once the programs have been downloaded into PLC, it can be monitored in the Diagram Workspace during execution. The Logo PLC provide the easy user interface to download the program, to upload the program, and to go back at online mode to see program desirable state. In this paper, the each home appliance is controlled by using PLC as shown in the flow charts.

CONTROLLING LAMP:

Set value A of atmospheric light is assumed and is sensed using LDR sensor, the output of sensor is given as input to PLC, where the condition $B \leq A$ is checked, where B is the sensed atmospheric light. When the condition is satisfied PLC sends on signal to lamp, In other case lamp is kept off as shown in figure 2.

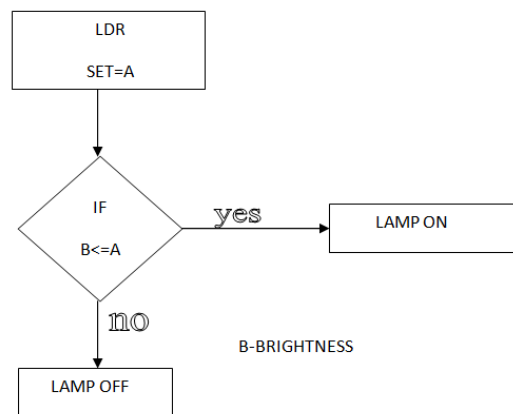

Figure 2. Lamp Control Flow chart

AUTOMATIC ON/OFF CONTROL OF WATER PUMP

The set value for high limit and low limit in a tank is assumed, a float switch is installed to sense the level of the water, the output of the level switch is given as input to the PLC. When the condition $L=A$ gets satisfied the motor is turned on, when the condition $L=B$ satisfied the motor is turned off. In other cases, the status of the motor is constant as shown in Figure 3.

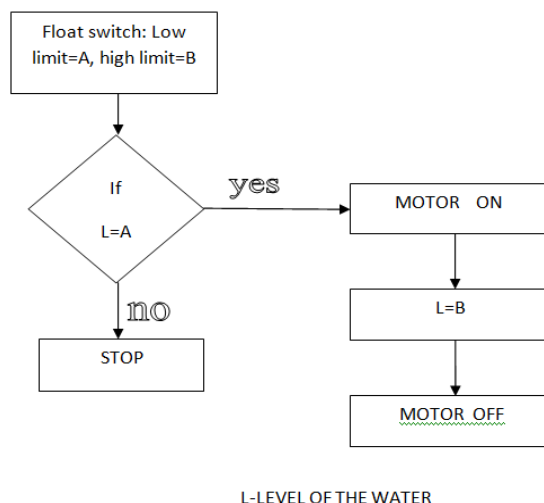

Figure 3. Motor Control flowchart

CONTROLLING FAN/HEATER/AIR CONDITIONER

The set value for the room temperature A is assumed and LM-35 temperature sensor is installed to sense the temperature and its output is given as the input to the PLC. When the condition $T \leq A$ gets satisfied the heater is turned on. In other case the heater is in off state as shown in Figure 4.

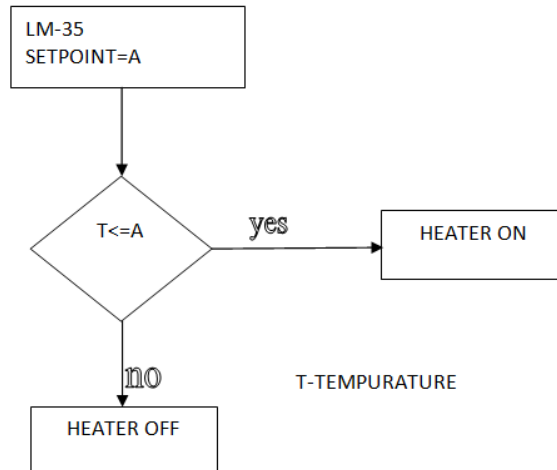

Figure 4.Fan Control flowchart

IV.RESULT AND DISCUSSION

In this paper, the real time data acquisition monitoring and control system has been developed using Programmable Logic Controller and is highly effective, efficient and robust. A number of input-output modules are attached to a PLC providing its expandability and competence. The new expansion modules can be either digital or analogue and in the present work digital modules are used. The ease of programming and networking of sensors with PLC demonstrates the high user friendliness of the device. A single PLC can control whole industry as it easily replaces the old, obsolete and cumbersome relay logics. Hence the present work is of much importance to the electrical engineers and designers. During the operation, all activities that occur can be observed by the computer using Logo PLC. The system needs to be debugged along the way and fine-tuned if necessary. The system is test run thoroughly until it is safe to be operated. The prototype was mainly built by combining the mechanical design and the electrical design. The system requires external power supply of 24 V DC and 220 V AC. The requirement of 24 V DC voltages is fulfilled with the help of SMPS. The external power supply of 240 V AC is converted into 24 V DC through SMPS. The reason of choosing external Power Supply is that the PLC is operated on 24 V DC which is not available without any SMPS or external Power Supply.

V. CONCLUSION

The theory and concept of the Home Automation System is based on the control system. In electrical design, the features and functions of the electrical components are required to determine the system requirement. Furthermore, the theoretical of the wiring system is required for connecting the inputs and outputs devices to PLC. In programming design, understandings of the desired control system and how to use the Ladder Diagram to translate the machine sequence of operation are the most important parts, because it has direct effect on the system performance. The main aim in this process is to apply PLC to design Home Automation system and all objectives in this project were successfully done as planned. Finally, the basic control system and logic design application can be used as a reference to design other applications of automation system, and can also be used as a teaching material for the Industrial Control subject.



ISSN (Print) : 2320 – 3765
ISSN (Online): 2278 – 8875

International Journal of Advanced Research in Electrical, Electronics and Instrumentation Engineering

An ISO 3297: 2007 Certified Organization

Volume 5, Special Issue 1, March 2016

National Conference on Recent Trends in Electronics and Instrumentation Engineering (NCRTE 2K16)

1st & 2nd March 2016

Organized by

Department of Electronics & Instrumentation Engineering, Adhiyamaan College of Engineering, Hosur, Tamilnadu, India

REFERENCES

- [1] Xiaohu, G. and Z. Guangxi, Empowering ubiquitous services in next-generation smart homes. Inform. Technol. J., 5: 64-69,2006.
- [2] wikipedia.org/wiki/Programmable_logic_controller.
- [3] plc-solutions.blogspot.in/p/blog-page_27.html.
- [4] L.A. Bryan, E.A. Bryan, 1997. Programmable controllers: theory and implementation.
- [5] W. Bolton, 2009. Programmable Logic Controllers,2009.
- [6] PLC verses other Controllers - Article, 31-1-2008.
- [7] <http://www.wikipedia.org>, "PLCs," 2013.
- [8] http://www.thelearningpit/The_Advantages_of_Using_Programmable_Controllers_How.html.
- [9] www.theijes.com/papers/v2-i1/X02101490153.pdf