



Series ARC Fault Detection Using ARC Model and Discrete Wavelet Transform

Renjini Raveendran¹, Aparna Thampi²

PG Student [Power System], Dept. of EEE, Saintgits Engineering College, Kottayam, Kerala, India¹

Assistant Professor, Dept. of EEE, Saintgits Engineering College, Kottayam, Kerala, India²

ABSTRACT: Arc faults mainly occur because of electrical problems such as aging cables and loose connections. Generating high temperature and discharging molten metal, arc faults finally lead to electrical fires. Every year such fires bring great loss and damage. It is identified that conventional protecting technique is unable to break a circuit in the situation when a brief arc fault occurs and the arc current is below thermal or instantaneous trip levels. In this paper a new method is proposed for the detection of residential series arc fault. Firstly, suitable arc model is used to simulate series arc fault. Then based on fault detection algorithm the fault features are extracted using a signal processing technique called Discrete Wavelet Transform(DWT). Then by comparing different wavelets, db4 were found appropriate for extracting arc-fault features. The last feature also involved the use of thresholding, peak detection, and relay tripping. MATLAB were used to build and simulate arc-fault model.

KEYWORDS: Series arc fault model, Discrete wavelet transform, thresholding, peak detection

I.INTRODUCTION

During a typical year, home electrical problems account for 67,800 fires, 485 deaths, and \$868 million in property losses. Electrical fire accidents have become a very important part of fire accidents. Conventional circuit breakers and fuses play an effective role in protecting residential electrical circuits from over-current and short-circuit conditions. But they cannot prevent fire accidents caused by arc faults especially series arc fault.

Arc faults normally take place due to wiring problems. It is the reason for 40 000 home fires in the U.S. annually.

Mainly there are two types of arc faults exist: series and parallel. The first type shown in Fig. 1 is the most abundant and occurs when the single power conductor breaks. Maximum arc current is then limited by the load current due to the series connection, which is definitely smaller than the CB current rating and depending on the load and, hence, the arc current may or may not produce a significant amount of heat to create a fire[1].

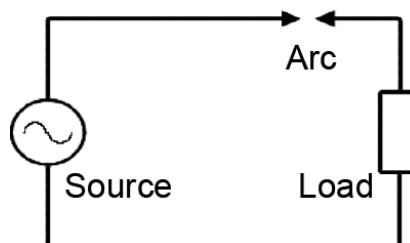

Fig. 1. Series arc-fault condition.

The parallel arc fault shown in Fig. 2 occurs between the neutral/ground and phase conductor, when the insulator is damaged due to mechanical, temperature stress, or aging[2]. In this case, high-impedance arc first melts and carbonizes the insulator, and later the low-impedance current path is formed. The path emerges from excessive heat, and if left uninterrupted, it could ignite a fire.

International Journal of Advanced Research in Electrical, Electronics and Instrumentation Engineering

(An ISO 3297: 2007 Certified Organization)

Vol. 4, Issue 11, November 2015

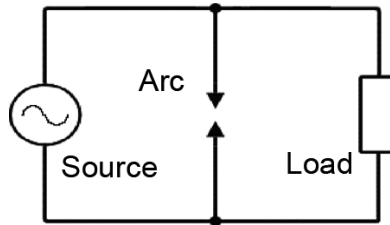

Fig. 2. Parallel arc-fault condition.

II. LITERATURE SURVEY

Conventional arc models are usually used to research the interaction between switching arc and circuit. It is important to simulate the fault arc for arc flash calculations, choice of electrical equipments and power system protection[4]. The fault arc could destroy electrical equipment and threaten human life. It is important to calculate the arc fault current for reducing loss. An arc model must be used for calculation of the arc fault current. There are a lot of arc models for describing the arc. Arc models can be classified in three groups: physical models, black box models and models based on graphics and diagrams. Black box models describe only the relation between input and output signals. Black box models define the interaction between the arc and the electrical circuit during the fault. In black box models, the arc is described by one differential equation or several differential equations relating the arc conductance which describes the energy balance of the arc column. In this paper Conventional arc models is used to simulate the fault arc[5].

III. SYSTEM DESCRIPTION

i) SERIES ARC FAULT MODEL

The arc fault itself can be defined as a self-supporting electrical discharge in conductive ionized gas[3], with the maximum current limited by circuit operation parameters. Arc may just reduce the lifetime of electrical devices (switch blades, generator, or motor brushes, etc.) or may become hazardous (e.g., in electrical wiring) and lead to dramatic outcomes like fires and explosions. The arc fault carries discontinuous, nonlinear, and non-sinusoidal characteristics. A number of models exist to describe its behavior. In this paper a suitable black box model is used. This arc model is based on energy balance theory, accordingly

$$\frac{dq}{dt} = (e * i) - P_{loss} \quad (1)$$

Where $\frac{dq}{dt}$ represents a change of storing energy per-unit arc length, $(e * i)$ is an input power per-unit arc length, i is an arc current, e is an electric intensity in the arc column, and p_{loss} is a power loss per-unit arc length.

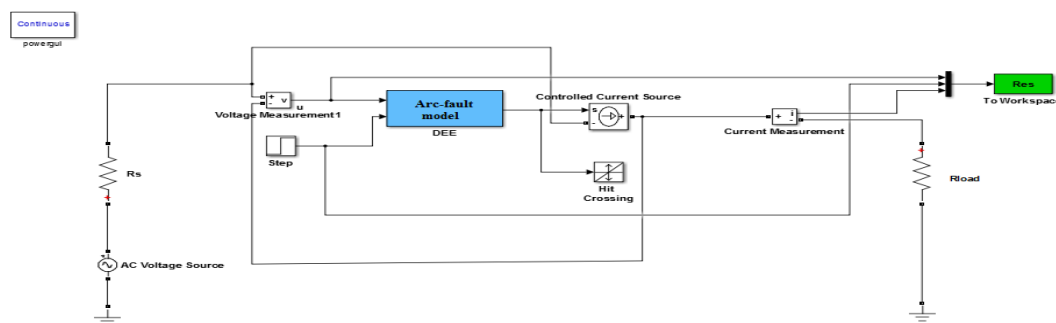

Fig. 3 Series arc-fault simulation model

International Journal of Advanced Research in Electrical, Electronics and Instrumentation Engineering

(An ISO 3297: 2007 Certified Organization)

Vol. 4, Issue 11, November 2015

Where u is arc voltage, u_c is arc voltage constant and T is arc time constant. Also, time constant can be represented in the form,

$$T = \frac{\alpha I_p}{L_p} \quad (3)$$

Where α is an empirically derived value equal to $2.9e-5$, I_p is maximum arc current (load for series or short circuit for parallel arc fault), L_p is the arc length, and is equal to $(15 \dots \dots \dots 30)L_p$ and must be found experimentally.

Using equations (2) and (3), it is possible to build a simulation model for the series arc-fault case. The MATLAB Simulink model is shown in Fig. 5. AC represents the power-supply source, RS models its internal resistance, RLOAD models load resistance (constant resistive load is assumed), and the VM1 block measures the voltage across arc (u). The differential equation editor (DEE) block calculates the arc current with g_0 as initial arc conductivity.

Arc current is then created using the Controlled Current Source block and measured by AM1 block. Res structure collects the data along with time stamp. The Hit Crossing block is required for the optimization of the simulation algorithm time step. The Start block defines the start time of the arc fault. The following parameters were used in the simulation: $g_0 = 1e4 S_m$, $\alpha = 2.9e - 5$, $I_p = 25A$, $L_p = 2mm$, $u_c = 25L_p$. System voltage is 120 V/60 Hz, RLOAD is 4 ohms, RS is 1 ohm, and arc start time is 0.03 s. Simulation results are shown in Fig. 6

ii) APPLICATION OF DISCRETE WAVELET TRANSFORM

Discrete Wavelet Transform is found to be useful in analysing transient phenomenon such as that associated with arc faults on the residential wiring and transmission lines. Multi-Resolution Analysis (MRA) is one of the tools of Discrete Wavelet Transform (DWT), which decomposes original, typically non-stationary signal into low frequency signals called approximations and high frequency signals called details, with different levels or scales of resolution. It uses a prototype function called mother wavelet for this. At each level, approximation signal is obtained by convolving signal with low pass filter followed by dyadic decimation, whereas detail signal is obtained by convolving signal with high pass filter followed by dyadic decimation. The three level decomposition of a signal is shown in Fig. 3.

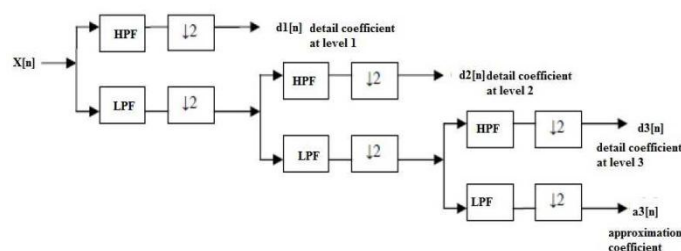

Fig.4 Three level decomposition of a signal

During the process of series arc fault detection, the signal data need to be analysed to find adequate information that can be useful for the fault detection, because it may not clearly appear in the original signal. That is why we apply a signal processing technique such as DWT. The implementation of DWT can be done either by command line functions or by using Wavelet Toolbox in MATLAB[6]. For this work, the detection algorithm was executed using command line functions. After inserting the arc model in the test system, the required signals has to be analysed in order to extract the fault features. To analyze the signal they have to undergo the process of signal decomposition. Signal decomposition is done with the help of an appropriate wavelet family. Several wavelet families were tested to extract the fault features using the Wavelet commands which are inbuilt in MATLAB.

Selecting an appropriate wavelet was a very important task in this step. The wavelet chosen should be similar to the signal that has to be filtered to give the best possible results. This “similarity” can be decided on the basis of

International Journal of Advanced Research in Electrical, Electronics and Instrumentation Engineering

(An ISO 3297: 2007 Certified Organization)

Vol. 4, Issue 11, November 2015

the cross- correlation between the two functions. It was found that *coif2,coif3,db4,db5, sym4* and *sym5* are the best options for signals under study and comparison of simulation using these wavelet function is shown on this paper. In this paper Daubechies family of wavelets is preferred because of their high number of vanishing moments making them capable of representing complex high degree polynomials.

The result of our simulations showed that D4 wavelet provided sufficiently good signal output. The wavelet has 4 constants (*c0, c1, c2, c3*) related to it whose values have been derived by Daubechies in her research work. These are normalized according to the need of the application where they are being used. Daubechies wavelet 4 (*db4*) is found appropriate for localizing this fault with a sampling frequency 30756-Hz. The details *d3* have been investigated for the proposed work. The time of occurrence of fault chosen was 0.03s and simulation time 0.1s. After setting the above parameters suitable MATLAB programs can be written .

iii) COMPARISON OF FEATURE EXTRACTION USING DIFFERENT WAVELET BASIS FUNCTION

The wavelet transform can selectively use various wavelet basis functions. In this section,we compare feature extraction using Daubechies, *symlet* and *coiflet* wavelets. Daubechies wavelet family is the most popular wavelet family used for feature analysis, due to orthogonal and compact support abilities. The Daubechies wavelet uses overlapping windows, so the results reflect all changes between pixel intensities. Since Daubechies averages over more pixels, it is smoother than the Haar wavelet. The extraction of feature using *coiflet* wavelet transform is different than any other wavelet used. *Coiflet* belongs to the family of Daubechies Wavelet Transforms. *Symlet* Transform belongs to the family of Haar wavelet. *Symlet* has compactly supported, nearly symmetrical, has arbitrary number of vanishing moments, exact reconstruction is possible. *Symlet* wavelet is used to extract the feature from the enhanced signal.It is a modified version of Daubechies wavelet with increased symmetry. *Symlet* is a quasisymmetric extension of the Daubechies wavelet. The properties of two wavelets are similar. There are 7 different functions from *sym2* to *sym8*.

iv) THRESHOLD, PEAK DETECTION, AND LOAD TRIP

The thresholding method is used to detect spikes in noisy signal components, obtained by performing three-level DWT decomposition of the original signal. A suitable thresholding method needs to be developed to determine if the signal level is higher than a particular value. After peaks have been identified, a final step for the algorithm is to calculate their repetition rate and trip the relay if the rate is higher than the predefined value. In current test implementation, it is assumed that series arc fault condition is 4 spikes, appearing within two fundamental periods . Passing peak signal and monitoring output, the load must be tripped. Algorithm can be illustrated more clearly using the flowchart shown in Fig.5

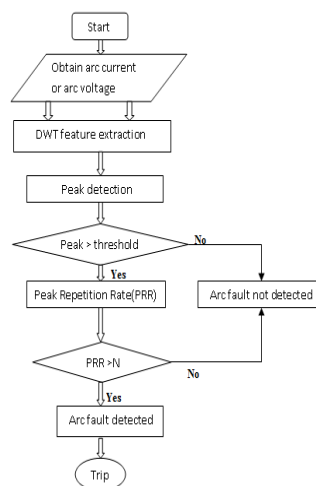

Fig. 5 Flowchart for series arc fault detection using DWT

IV. SIMULATION RESULT

A. Detection of Series arc Faults

Based on the details presented in above Section , simulation results are obtained and shown in Fig. 6.. As can be observed in Fig. 6, the series arc fault creates a distortion of sinusoidal load current. Due to this fact that it is obvious that by performing harmonic analysis, specific frequency components can be extracted, its level can be measured and based on some rule, a decision can be made to trip the load. The problem is that many electronic devices (e.g., switching regulators, inverters) also produce similar harmonic distortions, which makes it hard to distinguish.

Fast Fourier transform (FFT) is usually utilized for frequency- domain analysis. However, it does require the analysed signal to be stationary and periodic, which is not the case for power-supply current, containing disturbances. The other problem with FFT is the picket fence effect (resolution bias error), which is produced if a signal contains harmonics that are not integer multiples of resolution frequency. To overcome these drawbacks (along with couple others), a wavelet transform (WT) can be alternatively used to analyze signal time–frequency localization [7].

Daubechies Wavelets is a family of orthogonal wavelets with compact support. This allows extracting local signal disturbances with very high quality (ignoring fundamental components). Experimentally, it was found that series arc fault

disturbances in load current lay within 2 4-kHz range, which corresponds to detail level 3 (D3) of DWT on the 30756-Hz sampling rate. Daubechies wavelets db4 were found appropriate for extracting arc-fault features. Results of its operation are shown in fig.7.

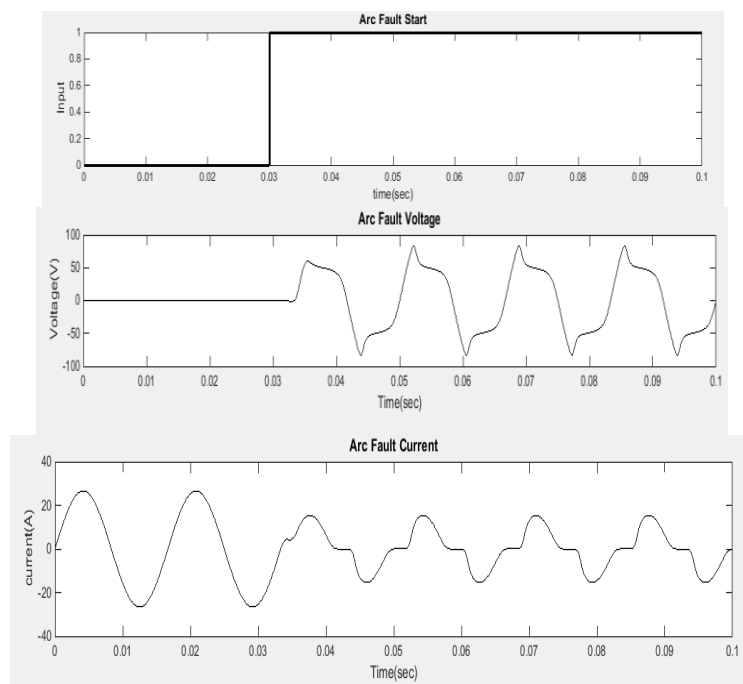

Fig. 6 Series arc-fault simulation results.

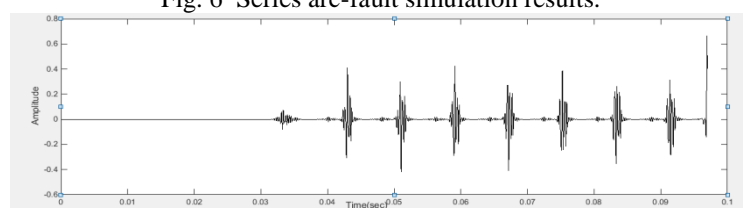

Fig. 7 Series arc-fault feature extraction using DWT and db4.

B. Feature Extraction Performance Using Different Wavelet

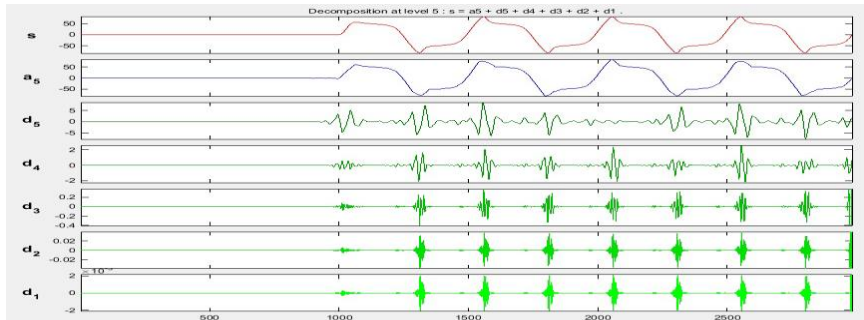

Fig.8(a) Five level decomposition using symlet

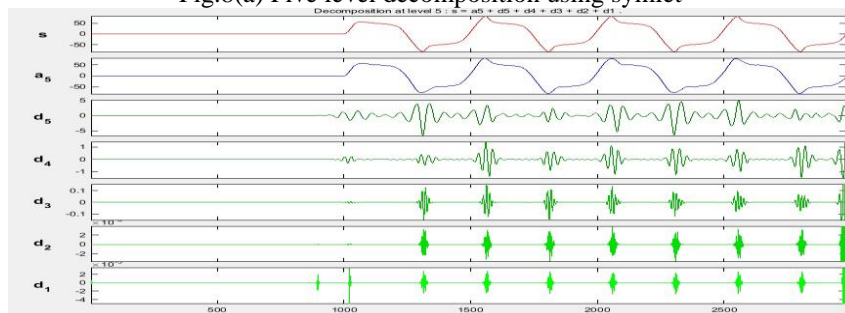

Fig. 8(b) Five level decomposition using coiflet

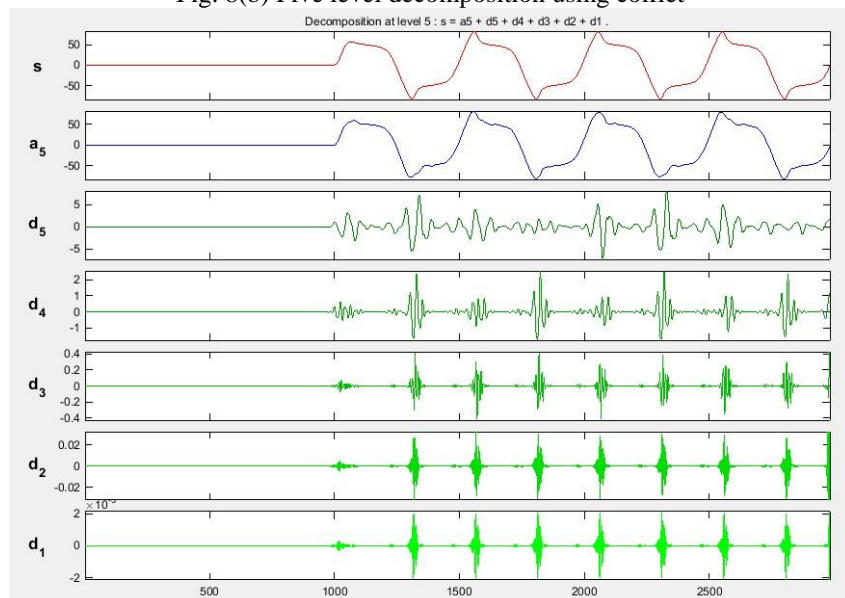

Fig.8(c) Five level decomposition using daubechies

C. Adaptive Threshold, Peak Detection, and Load Trip

Fig.9 demonstrates adaptive thresholding and peak detection. After peaks have been identified, a final step for the algorithm is to calculate their repetition rate and trip the relay if the rate is higher than the predefined value. It is assumed that series arc fault condition is 4 spikes, appearing within two fundamental periods (33 ms). Passing peak signal and monitoring output, the load must be tripped .



International Journal of Advanced Research in Electrical, Electronics and Instrumentation Engineering

(An ISO 3297: 2007 Certified Organization)

Vol. 4, Issue 11, November 2015

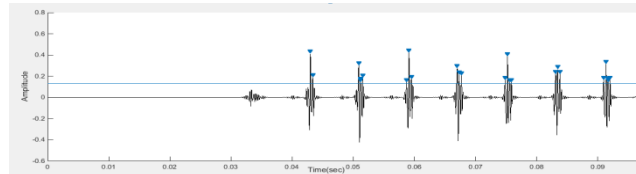

Fig. 9 DWT, level 3, (D3) and peak detection

VI. CONCLUSION

This paper focused on series arc faults detection. A new method for the identification of residential series arc fault based on MATLAB was presented. The current and voltage waveforms of arc faults in circuits with purely resistive loads is shown in this paper. It was found that arc faults have unique features in their curves of current and voltage. As described in this paper, firstly arc fault characteristics were obtained using suitable arc model. Then perform DWT analysis with optimum selection of wavelet function, which is accomplished by comparison of multiple simulation results.

REFERENCES

- [1] M. Naidu, T. Schoepf, and S. Gopalakrishnan, "Arc fault detection scheme for 42 V automotive DC networks using current shunt," *IEEE Trans. Power Electron.*, vol. 21, no.3, pp. 633–639, May 2006.
- [2] N. Zamanan, J. Sykulski, and A. K. Al-Othman, "Arcing High impedance fault detection using real coded geneticalgorithm," in *Proc. IEEE 3rd Lasted Asians Conf., Power Energy Syst.*, Japan, Aug.20–21, 2007, pp. 197–203.
- [3] I. Khan and M. Critchley, "Arc fault detector," 2000, vol. 25, no. 3, pp. 1–4. [Online]. Available: <http://ebookbrowse.com/arc-fault-detector-paper-pdf-d245318580>
- [4] Ling Yuan, Lin Sun, Huaren Wu, "Simulation of Fault Arc Using Conventional Arc Models" *Energy and Power Engineering*, 2013 Published Online July 2013 (<http://www.scirp.org/journal/epe>)
- [5] Arc Model Blockset, User Guide Version 2, Delft University of Technology, 2001.
- [6] Wavelet Toolbox User's Guide for MATLAB, Version 1, Mathworks 2009.
- [7] I. Daubechies, "The wavelet transform, time-frequency localization and signal analysis," *IEEE Trans. Inf. Theory*, vol. 36, no. 5, pp.961–1005, Sep. 1990.

BIOGRAPHY

Renjini Raveendran was born in Kerala, India. She received the B.Tech. Degree in electrical engineering from Kerala University, Kerala, India , in 2012, and the M. Tech degree in She is currently pursuing her M.Tech in Power Systems at Saintgits College of Engineering, Kerala, India.

Aparna Thampi was born in Kerala, India. She received the B.Tech. degree in electrical engineering from Mahatma Gandhi University, Kerala, India , in 2005, and the M. Tech degree in Industrial drives and control from RIT KOTTAYAM under Mahatma Gandhi University, in 2008. She currently works as assistant professor at Saintgits College of engineering, kottayam. Her research interests are in the areas of power electronics, ac motor drives and adaptive control.