



Integrating Renewable Energy Based Power Balancing System for Grid Tied Applications

N.Rajesh¹, B.Sajitha² and D.Nirmala³

PG Student [PED], Dept. of EEE, SNS College of Engineering College, Coimbatore, Tamilnadu, India¹

Assistant Professor, Dept. of EEE, SNS College of Engineering College, Coimbatore, Tamilnadu, India²

PG Student [PED], Dept. of EEE, SNS College of Engineering College, Coimbatore, Tamilnadu, India³

ABSTRACT: At present scenario, renewable energy sources are needed to meet the energy demand. They also mitigate environment pollution problems. The shortage of electrical energy demand can be meeting with renewable energy resources. A wind turbine (WT) and photovoltaic (PV) solar panels are primary energy sources. Grid connected renewable energy source like wind energy and solar energy are used to connect the hybrid system. Power electronics converters are used as interfacing device between hybrid system (WT & PV) and the utility grid. These converters are commonly based on a voltage source inverter (VSI) connected to the supply network. Grid side current control PWM technique is applied to the voltage source inverter which reduces THD value to less than 1%. Power balancing under heavy loaded conditions is also evaluated. The power factor correction is also determined. The simulation of power balancing conditions, total harmonic distortion (THD) and power factor correction (PFC) are studied with MATLAB Simulink.

KEYWORDS: Energy management system, energy storage system, hybrid system, renewable energies, power balancing conditions.

I. INTRODUCTION

Today, PV systems are widely applied to off-grid generation applications such as traffic warning lights, telecommunications, security systems and so on. Normally, when the electricity demand exceeds the supply of PV system, wind system or conventional electric generator can be added with PV system to create a hybrid system. Typically, a PV cell generates a voltage around 0.5 to 0.8 volts depending on the semiconductor and the built-up technology. This voltage is low enough as it cannot be of use. Therefore, to get benefit from this technology, tens of PV cells (involving 36 to 72 cells) are connected in series to form a PV module [7]. These modules can be interconnected in series and/or parallel to form a PV panel

In recent years wind energy has become an important part of electrical generation in many countries and its importance is continuing to increase. The Indian wind energy sector has an installed capacity of 17,365.03 MW (as on March 31, 2014). In terms of wind power installed capacity, India is ranked 5th in the World. [5]. The use of wind energy for electricity generation has been gaining popularity. The solar and wind energy is connected into the hybrid system. The output voltage is connected into the common dc link. The voltage source is used to convert the dc to ac supply. Here, current control pulse modulation technique is used to reduce the Total Harmonic Distortion (THD) value.

II. LITERATURE SURVEY

Numbers of researches on grid connected renewable energy were performed. Some of the major such works are described in this section.

Pablo Garcia, Carlos Andrés Garcia, Luis M. Fernandez, “ANFIS-Based Control of a Grid-Connected Hybrid System Integrating Renewable Energies, Hydrogen and Batteries”. IEEE Trans. Ind. Inf., vol. 10, No. 2, May 2014. This paper has presented and evaluated an ANFIS-based Energy Management System (EMS) of a grid-connected hybrid system, which is composed of renewable energy sources (WT and PV panels). The renewable energy sources operate at the Maximum Power Point [1]. The EMS maintaining constant the dc bus voltage. On the other hand, in



International Journal of Advanced Research in Electrical, Electronics and Instrumentation Engineering

(An ISO 3297: 2007 Certified Organization)

Vol. 4, Issue 3, March 2015

coordination with the EMS, the three phase inverter is controlled by an ANFIS-based controller in order to regulate the active and reactive power that the hybrid system is required to deliver with the grid.

M. P. Kazmierkowski, M. Jasinski, and G.Wrona, “DSP-based control of grid-connected power converters operating under grid distortions,” IEEE Trans. Ind. Inf., vol. 7, no. 2, pp. 204–211, May 2011. This paper proposes an extended Direct Power Control with Space Vector Modulation (DPC-SVM) scheme with improved operation performance under grid distortions[2]. A novel control scheme for Grid-Connected Converters (GCC) used as grid interface for Renewable Energy Sources (RES) has been presented in this work. It is based on generic Direct Power Control with Space Vector Modulation (DPC-SVM) control scheme and is expanded by additional modules for grid voltage dips compensation (VDC) and higher harmonics of grid current neutralization (HHC).

Marian P. Kazmierkowski, and Luigi Malesani, “Current Control Techniques for Three-Phase Voltage-Source PWM Converters”. IEEE Trans.Ind Elec, vol. 45, no. 5, October 1998. This paper is to present a review of recently used current control techniques for three-phase voltage source pulse width modulated converters[8]. Various techniques, different in concept, have been described in two main groups.linear and nonlinear. The first includes proportional integral stationary and synchronous) and state feedback controllers, and predictive techniques with constant switching frequency.

II. PROPOSED SYSTEM

The renewable energy source of solar and wind are connected to the hybrid system. Normally solar output is dc , the voltage can be either step up or step down .In the proposed system step up boost converter is connected to solar array, by the purpose of increase the output voltage . Wind output voltage is alternative current (AC), the output voltage is connected to diode rectifier. Then ac output is converted into dc. Solar and wind output dc voltage is connected in common dc link. A three phase voltage source inverter (VSI) is connected to the dc link. Grid side current control technique is applied to the voltage source inverter[2].The main task of the control scheme in a CC-PWM converter is to force the currents in a three-phase ac load to follow the reference signals. By comparing the command (i_{Ac} , i_{Bc} , i_{Cc}) and measured (i_A , i_B , i_C) instantaneous values of the phase currents, the CC generates the switching states (S_A , S_B , S_C) for the converter power devices which decrease the current errors so, grid side THD value can be reduced Here, LC filter is connected to the output voltage of VSI[3]. It is used to change the stepped waveform to sinusoidal waveform. Inverter output voltage is connected to the grid.

In this paper main scope is analysis and performance of the power balancing conditions in grid. Initially normal load is operating, at the time RES is not generate the electrical energy, grid power to support the load demand. When a RES generate the electrical power, inverter power is less than the load demand.at the time grid power support to meet the load demand. When an inverter power is equal to the load demand, there is no injection and consumption to grid[1]. When an inverter power is greater than the load demand, at the time the balancing power is injected to grid.

Heavy load will be turned on during a time period 0.8s to 1.4s.In grid connected renewable energy system the power factor is maintained at 0.9181. In power system THD value must be less than 5% . Total harmonic distortion value is observed in different timing period[4].

International Journal of Advanced Research in Electrical, Electronics and Instrumentation Engineering

(An ISO 3297: 2007 Certified Organization)

Vol. 4, Issue 3, March 2015

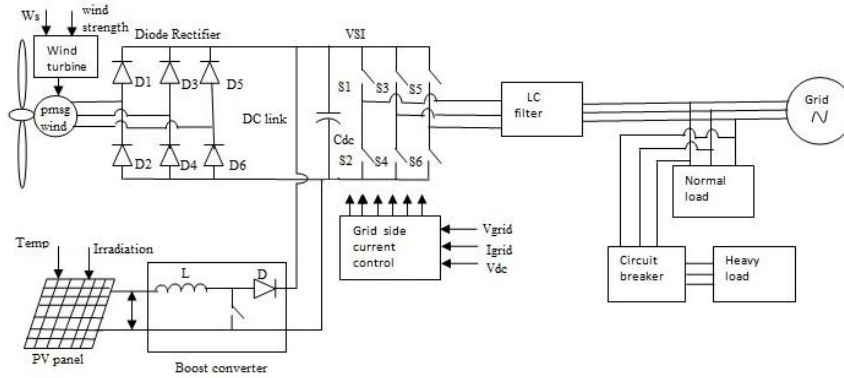

Figure 1: Proposed system block diagram

THD value minimize by employing current control PWM technique. In proposed system THD value is below 1% [11]. Total harmonic distortion (THD) value is tabulated given below.

S.No	Start time	THD (value in %)
1	0.4	0.27
2	1.2	0.78
3	1.6	0.11

Table 1: Total harmonic distortion value in grid current.

III. CURRENT CONTROL PULSE WIDTH MODULATION

Pulse-width modulation (PWM) or pulse-duration modulation (PDM), is a technique used to encode a message into a pulsing signal. It is a type of modulation. Although this modulation technique can be used to encode information for transmission, its main use is to allow the control of the power supplied to electrical devices [6]. In proposed system the three phase voltage source inverter has connected in grid. The current control pulse width modulation technique is used. The main task of the control scheme in a CC-PWM converter is to force the currents in a three-phase ac load to follow the reference signals. By comparing the command and measured instantaneous values of the phase currents, the CC generates the switching states for the converter power devices which decrease the current errors [8]. This process is repeated while getting a desired output.

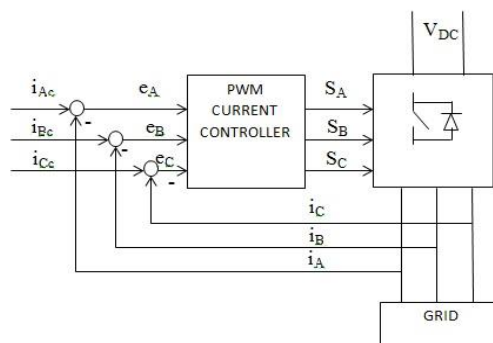

Figure 2: Current control pulse width modulation technique.

International Journal of Advanced Research in Electrical, Electronics and Instrumentation Engineering

(An ISO 3297: 2007 Certified Organization)

Vol. 4, Issue 3, March 2015

IV.SIMULATION

Power balancing conditions, total harmonic distortion and power factor correction from integrating renewable energy. This is justified with help of simulation. The simulations of various circuits are performed with the aid of software- MATLAB R2009b. This chapter deals with the simulations and the simulated results of various components in the project.

The Simulink model of grid connected renewable energy main block diagram is shown in below.

- Simulink model for integrating renewable energy in grid connected system & its simulated output.
- Simulink model of wind module & its simulated output.
- Simulink of solar array & its simulated output.

A.Simulink model for integrating renewable energy in grid connected system

The Simulink model grid connected system is given below. The renewable energy solar and wind is connected into the hybrid system. The sub model of solar and wind is given below.

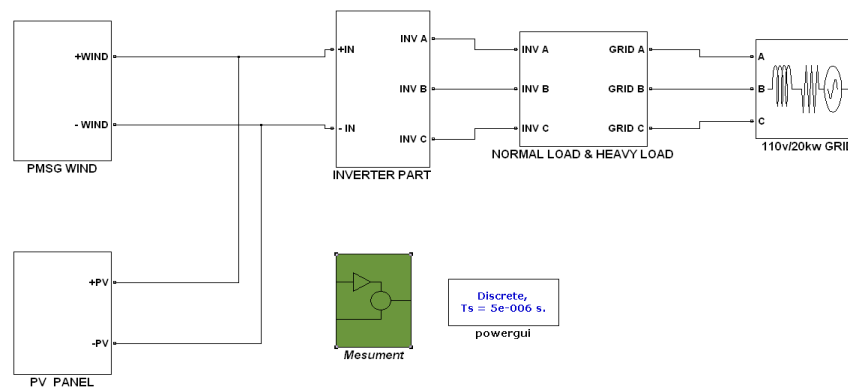

Figure 3: Main model of grid connected system

Normally wind energy output voltage is alternating current(AC), it can be converted into direct current by the purpose of connecting a common dc link. Solar output voltage is DC. Here, Boost converter is used to step up the DC voltage. The output dc voltage is also connected in the common dc link. The above Simulink model is described about the grid connected system

Initially renewable energy voltage will be oscillating due to wind speed. Initially the motor input voltage is consumed from grid. When a mechanical torque is positive, permanent magnet synchronous generator is act as a motor and mechanical torque is negative, power is generated [5]. The output power is connected to three phase rectifier; it converts a AC supply to DC supply. The three phase rectifier is used to convert the AC supply to DC supply.

Solar array output voltage is 35.2Volts, current is 9.897Amps and power 348.4 Watts. Solar array output current is connected to the ideal equivalent circuit of a solar cell. A current source in parallel with a single-diode. Discrete PI controller is used to control the MOSFET switch either ON or OFF.

V.RESULTS

A .Waveform of output power under power balancing conditions

The below waveform explained about power balancing conditions. here, there no power generated from renewable energy source, at the time grid support to meet the load demand. A renewable energy source starts to inject the power due to reduction of grid power consumption. Renewable energy power is greater than the load demand at the time period, balancing renewable energy power inject to the grid.

International Journal of Advanced Research in Electrical, Electronics and Instrumentation Engineering

(An ISO 3297: 2007 Certified Organization)

Vol. 4, Issue 3, March 2015

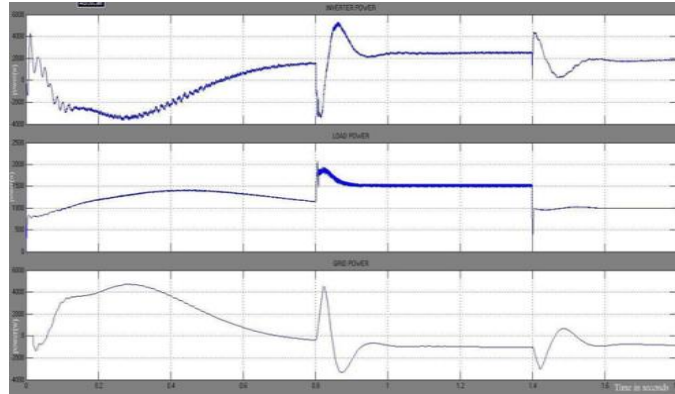

Figure 4: Power balancing conditions

B. Output waveform of wind voltage and wind current

The below waveforms are a wind voltage & current. During initial condition normal load will be operating. The heavy load will be turned on during the time period of 0.8 to 1.4 second. In the period wind output voltage and output current will be varied. Wind output voltage is varied due to the wind speed. So, The wind output voltage is not stable.

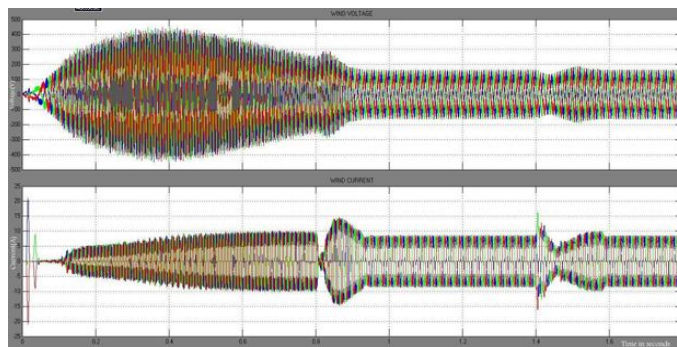

Figure 5: Wind energy output power

C. Output current waveforms of grid connected system

The below waveform is explained about the output current in grid system. The inverter output current is compensating the load current. The remaining current is injected to the grid current. Initially renewable energy output voltage is oscillating due to the wind speed and weather condition. In this paper the dclink voltage is 200 Volts. The generating inverter current is 10Amps. Load current is 5Amps, when the heavy load is ON at the time period load will increase.

International Journal of Advanced Research in Electrical, Electronics and Instrumentation Engineering

(An ISO 3297: 2007 Certified Organization)

Vol. 4, Issue 3, March 2015

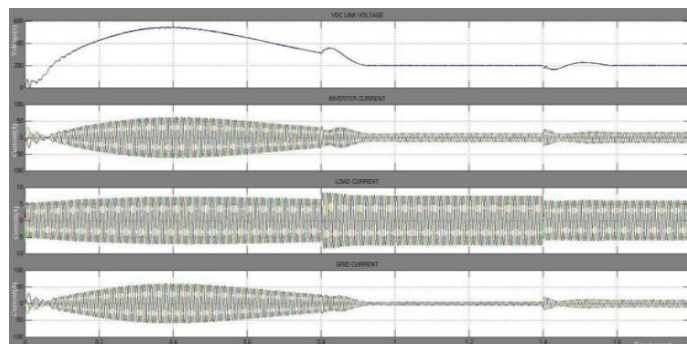

Figure 6: Inverter power and load demand

D. Output waveform of Total Harmonic Distortion

Total harmonic distortion value is observed in different timing period. THD value minimize by employing current control PWM technique. Here, the least THD value is 0.11%. THD value is absorbed in various time period. When the switching frequency is increase at the time total harmonic distortion value is decreased.

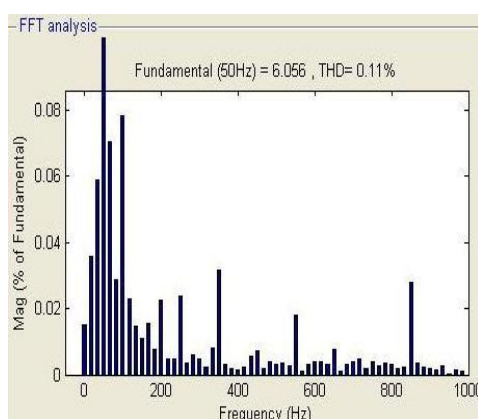

Figure 7: Total harmonic distortion values

VI. CONCLUSION

In this paper an integrating renewable energy based power balancing system for grid tied applications in hybrid system has been designed and evaluated. The hybrid system is composed of wind turbine unit and photovoltaic panels. Power balancing conditions are also evaluated. In the grid side reduction of total harmonic distortion (THD) and the power factor correction (PFC) are done. THD value is minimized by employing current control PWM technique. Total harmonic distortion value is observed in different time period and the corrected power factor is 0.9181. The Power balancing conditions are evaluated from 0.8 to 1.4 seconds after the heavy load is switched on. In proposed system THD value is 0.11. The observe values are obtained by simulation using MATLAB software.

REFERENCES

- [1] Pablo García, Carlos Andrés García and Luis M. Fernández, "ANFIS-Based Control of a Grid-Connected Hybrid System Integrating Renewable Energies, Hydrogen and Batteries". IEEE Trans. Ind. Inf., vol. 10, No. 2, May 2014.
- [2] M. P. Kazmierkowski, M. Jasinski, and G. Wrona, "DSP-Based Control of Grid-Connected Power Converters Operating under Grid Distortions," IEEE Trans. Ind. Inf., vol. 7, no. 2, pp. 204–211, May 2011.



International Journal of Advanced Research in Electrical, Electronics and Instrumentation Engineering

(An ISO 3297: 2007 Certified Organization)

Vol. 4, Issue 3, March 2015

- [3] SaeidHagbhin, Sonja Lundmark, Mats Alaküla, and Ola Carlson, “Grid-Connected Integrated Battery Chargers in Vehicle Applications” IEEE Trans. Ind. electronics, vol. 60, no. 2, Feb 2013.
- [4] Medina, J. Segundo-Ramirez, P. Ribeiro, W. Xu, K. L. Lian, G. W. Chang, V. Dinavahi, and N. R. Watson, “Harmonic Analysis in Frequency and Time Domain” IEEE Trans on Power Delivery, vol. 28, no. 3, July 2013.
- [5] FredeBlaabjerg and Ke Ma, “Future on Power Electronics for Wind Turbine Systems” IEEE Journal Of Emerging And Selected Topics In Power Electronics, vol. 1, no. 3, September 2013.
- [6] ArnaldoArancibia , Kai Strunz, and Fernando Mancilla-David, “A Unified Single- and Three-Phase Control for Grid Connected Electric Vehicles” IEEE Trans ON Smart Grid, vol. 4, no. 4, Dec 2013.
- [7] Kai Strunz, EhsanAbbasi, and Duc Nguyen Huu, “DC Microgrid for Wind and Solar Power Integration” IEEE Journal of Emerging and Selected Topics in Power Electronics, vol. 2, no. 1, March 2014.
- [8] Marian P. Kazmierkowski and Luigi Malesani, “Current Control Techniques for Three-Phase Voltage-Source PWM Converters” IEEE Trans on Ind. Elec, vol. 45, no. 5, oct 1998.
- [9] K.Gurumoorthy, D.Prince Winston, D.EdisonSelvaraj and Lieutenant.J.Ganesan, “Reduction of Harmonic Distortion by applying various PWM and Neural Network Techniques in Grid connected Photovoltaic Systems”IJAREEIE,Vol. 2, Issue 12, December 2013.

BIOGRAPHY



Rajesh.N received BE degree in Electrical&Electronics Engineering from Shanmuganathan Engineering College, ANNA University, Chennai, India, in 2013. He is currently pursuing ME degree in power electronics and drives at SNS College of Engineering, ANNA University, Chennai, India.

His research interests are renewable energy technology, and micro grids.



Sajitha.B received BE degree in Electrical&Electronics Engineering from Karpagam College of Engineering, ANNA University, Coimbatore, India, in 2009. She received ME degree in power electronics and drives at, ANNA University, Coimbatore, India, in 2011. At present she is working as an Assistant Professor at SNS college of Engineering, Coimbatore, India. She is a member of ISTE.

Her research interest is dc to dc converter



Nirmala.D received BE degree in Electrical&Electronics Engineering from Dr.NGP Institute of Technology, ANNA University, Chennai, India, in 2012. She is currently pursuing ME degree in power electronics and drives at SNS College of Engineering, ANNA University, Chennai, India.

Her research interests are renewable energy technology, and power electronics and drives.